



CAREER POINT

Study Material for Pre foundation Class 10
Prepared by Career Point Kota Experts

CONTENTS OF THE PACKAGE AT A GLANCE

Class X

Physics	Chemistry	Biology
<ul style="list-style-type: none">◆ Electricity◆ Magnetic effect of Electric Current◆ Light-Reflection & Refraction◆ Human Eye and Colourful world	<ul style="list-style-type: none">◆ Chemical Reactions & Equations◆ Acids, Bases and Salts◆ Metals & Non-Metals◆ Carbon and its compounds◆ Periodic classification of elements	<ul style="list-style-type: none">◆ Nutrition◆ Respiration◆ Transportation◆ Excretion◆ Control & Coordination◆ Our Environment◆ How Do Organisms Reproduce◆ Heredity and Evolution◆ Management of Natural Resources

Mathematics [Set-1]	Mathematics [Set-2]	Mental Ability
<ul style="list-style-type: none">◆ Real Numbers◆ Polynomials◆ Pair of Linear Equations in two variables◆ Quadratic equations◆ Arithmetic Progressions◆ Triangles◆ Coordinate Geometry	<ul style="list-style-type: none">◆ Introduction to Trigonometry◆ Some Applications of Trigonometry◆ Circles◆ Areas Related to Circles◆ Surface Areas and Volumes◆ Statistics◆ Probability	<ul style="list-style-type: none">◆ Logical sequence of words◆ Pyramid test◆ Calendar test◆ Clock test◆ Data sufficiency◆ Data redundancy◆ Cube test◆ Dice test◆ Mirror & water image◆ Paper cutting & folding◆ Figure partition & counting◆ Completion & formation of figures◆ Embedded figure◆ Non-verbal series◆ Non-verbal analogy◆ Non-verbal classification◆ Dot situation

Social Science [Set-1]

History

- ◆ The Rise of Nationalism in Europe
- ◆ The Nationalist Movement in Indo-China
- ◆ Nationalism in India
- ◆ The Making of a Global World
- ◆ The Age of Industrialisation
- ◆ Print Culture and The Modern World

Economics

- ◆ Development
- ◆ Sectors of the Indian Economy
- ◆ Money And Credit
- ◆ Globalisation And The Indian Economy
- ◆ Consumer Right

Social Science [Set-2]

Geography

- ◆ Resource & Development
- ◆ Forest And Wildlife Resources
- ◆ Water Resources
- ◆ Agriculture
- ◆ Minerals And Power Resources
- ◆ Manufacturing Industries
- ◆ Lifelines of National Economy

Civics

- ◆ Power Sharing
- ◆ Federalism
- ◆ Gender, Religion and Caste
- ◆ Political Parties
- ◆ Outcomes of Democracy

English [Set-1]

- ◆ Letter writing
- ◆ Article writing
- ◆ Story writing
- ◆ Integrated grammar
- ◆ A letter to god
- ◆ Nelson mandela : long walk to freedom
- ◆ Two stories about flying
- ◆ From the diary of anne frank
- ◆ The hundred dresses – i
- ◆ The hundred dresses – ii
- ◆ Dust of snow
- ◆ Fire and ice
- ◆ A tiger in the zoo
- ◆ How to tell wild animals
- ◆ The ball poem
- ◆ Amanda!
- ◆ Animals
- ◆ A triumph of surgery
- ◆ The thief's story
- ◆ The midnight visitor
- ◆ A question of trust
- ◆ Footprints without feet
- ◆ Glimpses of india
- ◆ Mijbil the otter
- ◆ Madam rides the bus
- ◆ The sermon at benares
- ◆ The proposal
- ◆ The trees
- ◆ Fog
- ◆ The tale of custard the dragon
- ◆ For anne gregory
- ◆ The making of a scientist
- ◆ The necklace
- ◆ The hack driver
- ◆ Bholi
- ◆ The book that saved the earth

English [Set-2]

- ◆ Noun
- ◆ Pronoun
- ◆ Adjective
- ◆ Adverb
- ◆ Determiners
- ◆ Connectors
- ◆ Prepositions
- ◆ Tense
- ◆ Passivization
- ◆ Reported speech
- ◆ Modals
- ◆ Subject verb concord
- ◆ Conditionals
- ◆ Error spotting
- ◆ Reading comprehension
- ◆ Fillers/sentence completion
- ◆ Cloze test
- ◆ Missing sen./jumbled sentences & paragraphs
- ◆ Sentence improvement
- ◆ Synonyms
- ◆ Antonyms
- ◆ Idioms and phrases
- ◆ Phrasal verbs
- ◆ One word substitution
- ◆ Spelling

Note to the Students

Career Point offers this Class 10 Study Package to support complete learning for school curriculum as well as Olympiad and foundation-level exams. This sample represents our set of nine books: **Physics, Chemistry, Biology**, two **Mathematics** books, two **Social Science** books, two **English** books and **Mental Ability**. Each book provides clear concepts, illustrative examples and ample practice to strengthen understanding and build analytical skills. The material is designed to develop a strong academic base and prepare students with confidence for board exams, higher classes and future competitive studies.

Mind Map

Each chapter contains many articles (Concepts, Theories etc.). Mind map interconnect all these articles logically. By this student can understand whole chapter articles interconnectivity clearly in a single picture frame.

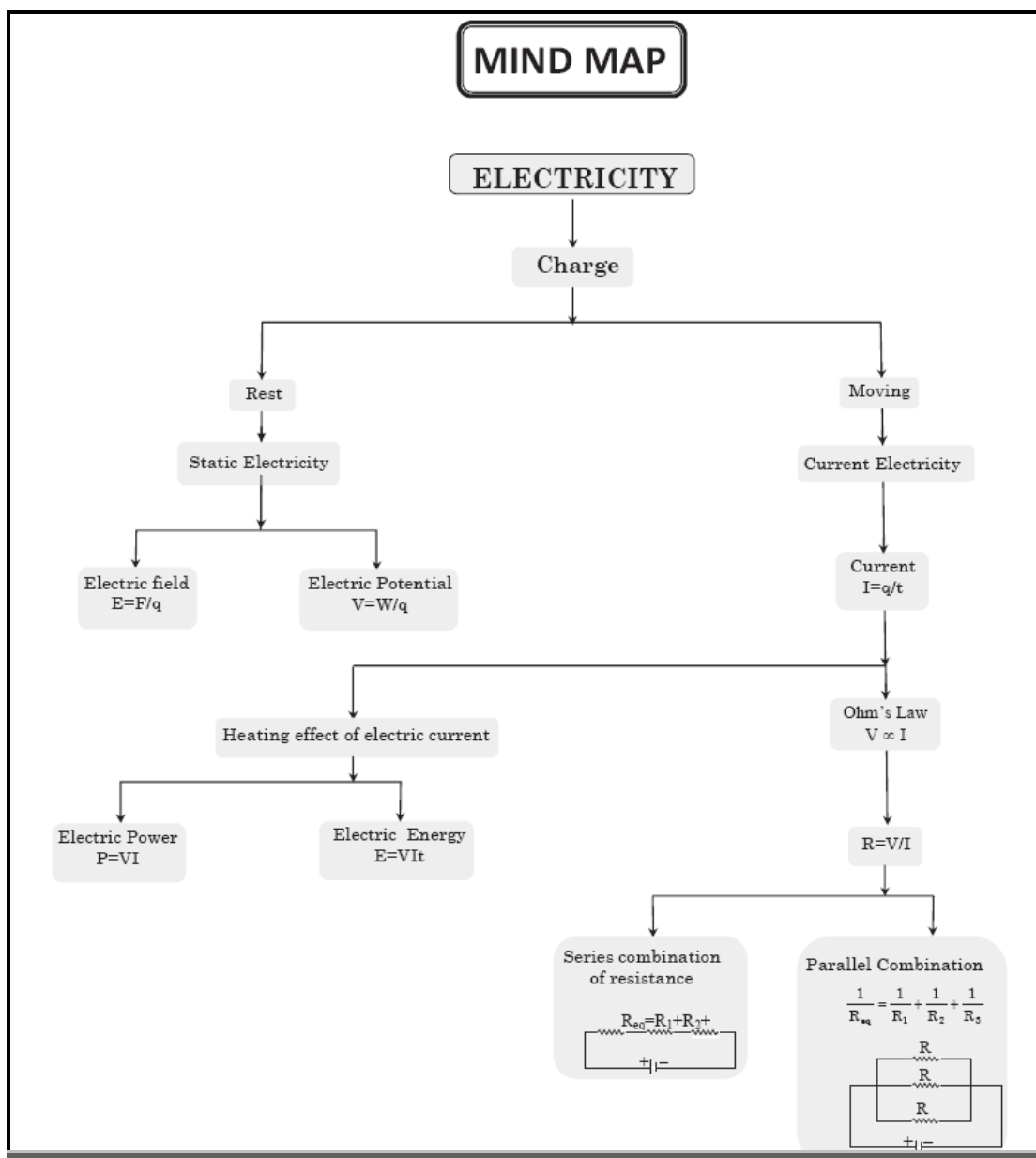

Theory & Concepts

Each chapter consist of exhaustive theory which gives conceptual clarity and command over topics. Appropriate explanation of theory with the help of images, diagrams, flowcharts, mind maps, info graphics, and tables.

ELECTRICITY

Electric Charge

◆ Definition

Electric charge may be defined as the intrinsic property of certain fundamental particles (electron, proton, etc.) due to which they produce electric and magnetic effects.

◆ Charge on a Macrobody

Excess or deficiency of electrons in a body is equal to the charge on a macrobody. A body having excess of electrons is negatively charged and a body having deficiency of electrons is positively charged.

From the study of atomic structure, we know that an atom consists of a central part called nucleus and around the nucleus there are a number of electrons revolving in different paths or orbits. The nucleus contains protons and neutrons. A proton is a positively charged particle while a neutron has no charge. Therefore, the nucleus of an atom bears a positive charge. An electron is a negatively charged particle having negative charge equal to the positive charge on a proton. Normally, the number of electrons is equal to the number of protons in an atom. Therefore, an atom is neutral as a whole; the negative charge on electrons cancelling the positive charge on protons. This leads to the conclusion that under ordinary conditions, a body is neutral i.e. it exhibits no charge.

Competitive Level

Competitive level is specially designed for competition exam requirements and to better understanding the concepts, well explained theory, clearly explained formulas with good number of quality examples are given in this.

COMPETITIVE LEVEL

Coulomb's Law

Charles Augustine De Coulomb studied the interaction forces of charged particles in detail in 1784. He used a torsion balance. On the basis of his experiments he established Coulomb's law. According to this law, the force of attraction or repulsion between two stationary point charges is directly proportional to the product of charges and inversely proportional to the square of distance between them. This force acts along the line joining the two. If q_1 & q_2 are charges in consideration, r , the distance between them and F , the force acting between them

In Chapter Example

To understand the application of concepts, there is **in chapter solved example** are given. It contains large variety of all types of solved examples with explanation to ensure understanding the application of concepts.

Ex.5 How much energy is given to each coulomb of charge passing through a 6 V battery?

Sol. Energy required to each coulomb of charge passing through a 6 V battery is $U = VQ = 6 \text{ V} \times 1 \text{ C} = 6 \text{ J}$.

Ex.6 What is meant by saying that the potential difference between two points is 1 V?

Sol. If 1 Joule of work is required to move charge of 1C from one point to another, then it is said that the potential difference between the two points is 1V.

Ex.7 Name a device that helps to maintain a potential difference across a conductor. How it helps to maintain the current in a given electric circuit? What energy changes takes place in it?

Sol. To maintain a potential difference across a conductor we use a device known as cell. The chemical action within a cell generates the potential difference across the terminals of the cell, even when no current is drawn from it. When the cell is connected to a conducting circuit element, the potential difference sets the charges in motion in the conductor and produces an electric current. In order to maintain the current in a given electric circuit, the cell has to expend its chemical energy stored in it hence cell converts chemical energy into electrical energy to move charges in electric circuit.

Practice Exercises

Includes three sets of exercises covering all the topics. Helps the students to assess their strengths and weaknesses and work on them accordingly. Separate exercises for subjective as well as objective questions and previous year competitive exams questions (NTSE, Olympiads)

EXERCISE-1

▶ Very Short Answer Type Questions

- Q.1** What is represented by joule/coulomb?
- Q.2** What is the function of electric switch in electric circuit?
- Q.3** A wire of resistivity 10 ohm-meter is stretched to double its length. What is its new resistivity?
- Q.4** What is the SI unit of Power?
- Q.5** A charge of 2C moves between two plates, maintained at a p.d of 1V. What is the energy acquired by the charge?

▶ Short Answer Type Questions – Type I

- Q.6** Draw a schematic diagram of a typical electric circuit comprising a cell, an electric bulb, an ammeter and a plug key.

- Q.13** A TV set shoots out a beam of electrons. The beam current is $10\mu\text{A}$.
(a) How many electrons strike the TV screen in each second?
(b) How much charge strikes the screen in a minute?
- Q.14** (a) Why do copper or aluminium wires generally used for electrical transmission and distribution purposes?
(b) Two wires, one of copper and other of manganin, have equal lengths and equal resistances. Which wire is thicker? Given that resistivity of copper is lower than that of manganin.
- Q.15** Two conductors X and Y of circular cross-section have radii in the ratio of 1: 2, length in the ratio 1: 3 and resistivities in the ratio of 3: 1, then in which ratio their resistances are?

EXERCISE-2

- Q.1** When a body is negatively charged by friction, it means
(A) the body has acquired excess of electrons
(B) the body has acquired excess of protons
(C) the body has lost some electrons
(D) the body has lost some neutrons
- Q.2** When the distance between the charged particles is halved, the force between them becomes
(A) One-fourth (B) Half
(C) Double (D) Four times
- Q.3** How many electrons in 1 s constitute a current of 1 A?
(A) 6.25×10^{18} (B) 6.25×10^{12}
(C) 6.25×10^{11} (D) 6.25
- Q.9** What is not true for electric charge :
(A) Electric charge is scalar quantity
(B) Charge on a body may be + ve or – ve
(C) S.I. unit of charge is coulomb
(D) One coulomb is charge of one electron
- Q.10** A metallic sphere has a charge of $10\mu\text{C}$. A unit negative charge is brought from A to B both 100 cm away from the sphere but A being east of it while B being on west. The net work done is
(A) Zero (B) 2/10 joule
(C) -2/10 joule (D) -1/10 joule
- Q.11** 1 Coulomb is equal to
(A) 1 amp \times 1 sec (B) 1 amp / 1 sec
(C) 1 joule \times 1 amp (D) 1 joule / 1 sec

EXERCISE-3

(Previous Year Questions - NTSE & NSO)

- Q.1** In the given circuit diagram, the value of resistance X in ohm when the bridge is balanced (galvanometer current is zero) will be

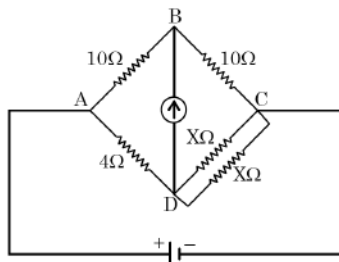

- (A) 4 (B) 8
(C) 10 (D) 12

- Q.2** In the following figure, the equivalent resistance between the points A and B in ohm will be

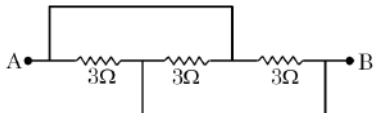

- (A) 1 (B) 2 (C) 3 (D) 9

- Q.3** In the circuit shown in figure, the current flowing through 5 Ω resistance is

^

- Q.5** A uniform wire when connected directly across a 220V line produces heat H per second. If the wire is divided into n-parts and all parts are connected in parallel across a 220 V line, the heat produced per second will be

- (A) H/n (B) n²H
(C) H/n² (D) nH

- Q.6** One Volt is equal to

- (A) 1 Joule
(B) 1 Newton/Coulomb
(C) 1 Joule/Coulomb
(D) 1 Coulomb/Newton

- Q.7** On a bulb it is written as 220 Volt and 60 watt. Find out the resistance of the bulb and the value of the current flowing through it

- (A) 806.66 ohm / 0.27 ampere
(B) 500 ohm / 2 ampere
(C) 200 ohm / 4 ampere
(D) 100 ohm / 1 ampere

- Q.8** A comb run through one's dry hair attracts small bits of paper. This is due to

Answer key

Answer key is provided at the end of the exercise sheets.

ANSWER KEY															
EXERCISE - 1															
3.	40Ω														
5.	2 J														
8.	$\frac{R_1}{R_2} - \left(\frac{r_2}{r_1}\right)^2$														
10.	$1.44 \times 10^6 \text{ J}$														
12.	$2qV/\ell$														
13.	(a) 6.25×10^{12} (b) $6 \times 10^{-4} \text{ C}$														
EXERCISE - 2															
Ques.	1	2	3	4	5	6	7	8	9	10	11	12	13	14	15
Ans.	A	D	A	D	C	C	C	C	D	A	A	A	C	A	B
Ques.	16	17	18	19	20	21	22	23	24	25	26	27	28	29	30
Ans.	D	C	D	A	A	B	D	D	B	C	C	A	C	C	A
EXERCISE - 3															
Ques.	1	2	3	4	5	6	7	8	9	10	11	12	13	14	15
Ans.	B	A	B	B	B	C	A	C	A	A	C	B	D	B	A
Ques.	16	17	18	19	20	21	22	23	24						
Ans.	B	A	A	B	A	B	D	A	C						

SOLUTIONS

EXERCISE-1

Very Short Answer Type Questions

Sol.1 As all know $V = \frac{W}{Q}$
 v = potential difference
 W = work
 Q = charge
 W = joules Q = coulomb
 so, quantity will be potential

Sol.2 It is used to interrupt the flow of Electric current.

Sol.3 resistivity is the property of material which is independent of dimension of material so there is no change in resistivity $\rho=10 \Omega\text{-m}$

Sol.4 Watt is SI unit of Power .

Sol.5 using Relation $V = \frac{W}{Q} \Rightarrow 1 = \frac{W}{2}$
 $\Rightarrow W = 2$ joules in form of energy

Short Answer Type Questions – Type I

Sol.6

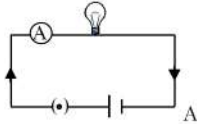

Sol.9 (a)

$$R = \frac{\rho \ell}{A} \quad l = \text{doubled} \Rightarrow \text{Area becomes half}$$

$$R^1 = \frac{\rho(2\ell)}{A/2}$$

$$R^1 = 2R$$

(b) resistivity is the property of materia which is independent of dimension o material so there is no change in resistivity

Sol.10 $p = \frac{E}{t} \Rightarrow E = p \times t = 1200 \times 20 \times 60$

$$E = 1440 \text{ KJ}$$

Short Answer Type Questions – Type II

Sol.11 (i) Likes charges repel and unlike charge attract
 (ii) Quantization of charges
 (iii) Charge always associated with mass.

Sol.12 $I = \frac{Q}{t} \quad t = \frac{d}{v} = \frac{\ell}{v}$

$$I = \frac{2qv}{\ell}$$

Sol.13 (a) $I = \frac{Q}{t}$

PHYSICS

ELECTRICITY

Chapter Outline

- ❖ Electric Charge
- ❖ Static & Current Electricity
- ❖ Electric field
- ❖ **Electric Potential and Potential Difference**
- ❖ **Electric Potential Energy**
- ❖ **Electric Current & Circuits**
- ❖ Ohm's Law
- ❖ Resistance of a Conductor
- ❖ Combination of Resistances
- ❖ Heating Effect of Electric Current

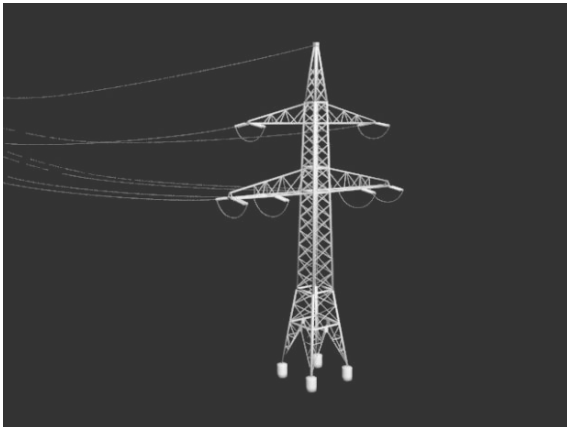

MIND MAP

ELECTRICITY

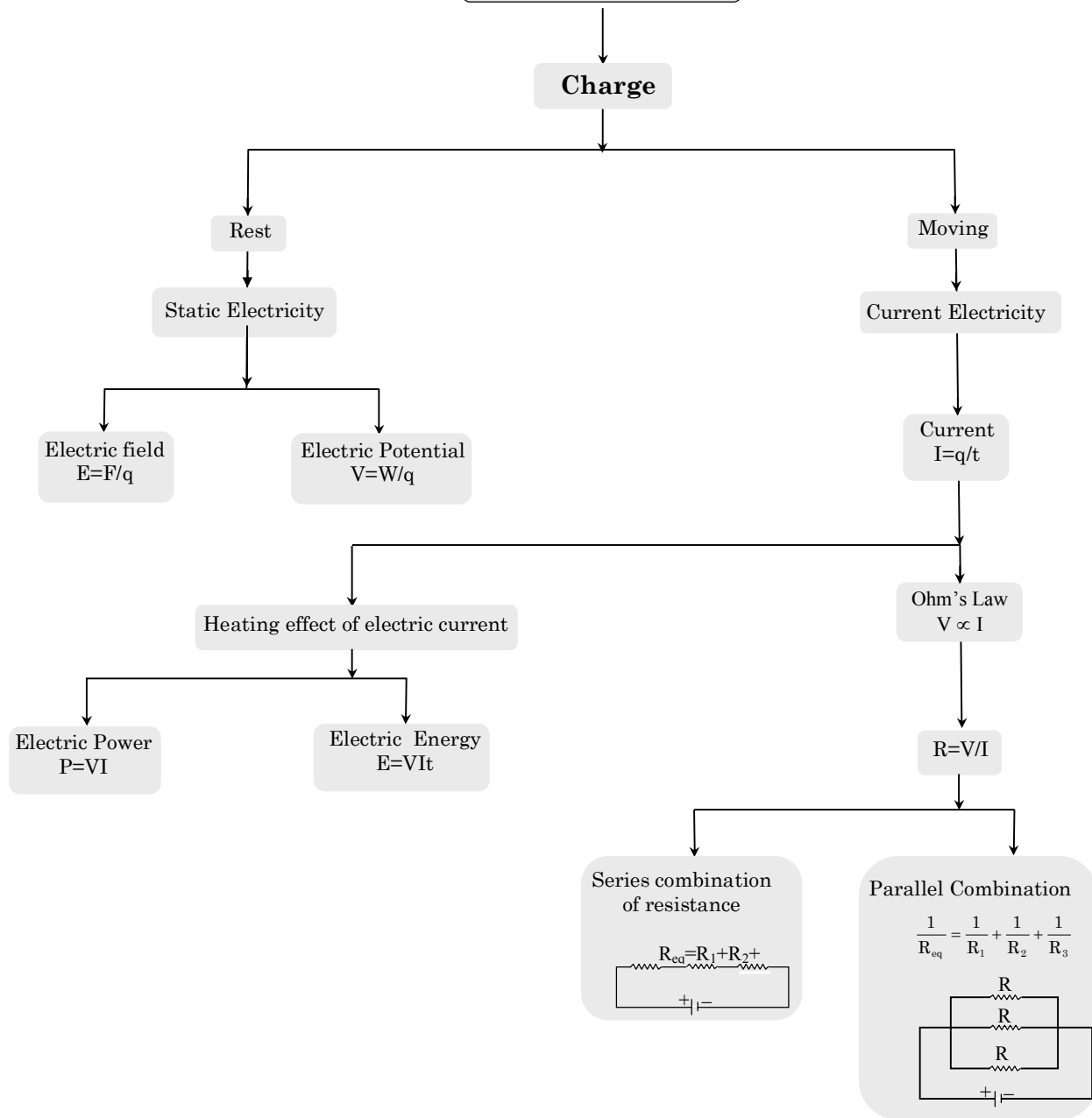

ELECTRICITY

Electric Charge

◆ Definition

Electric charge may be defined as the intrinsic property of certain fundamental particles (electron, proton, etc.) due to which they produce electric and magnetic effects.

◆ Charge on a Macrobody

Excess or deficiency of electrons in a body is equal to the charge on a macrobody. A body having excess of electrons is negatively charged and a body having deficiency of electrons is positively charged.

From the study of atomic structure, we know that an atom consists of a central part called nucleus and around the nucleus there are a number of electrons revolving in different paths or orbits. The nucleus contains protons and neutrons. A proton is a positively charged particle while a neutron has no charge. Therefore, the nucleus of an atom bears a positive charge. An electron is a negatively charged particle having negative charge equal to the positive charge on a proton. Normally, the number of electrons is equal to the number of protons in an atom. Therefore, an atom is neutral as a whole; the negative charge on electrons cancelling the positive charge on protons. This leads to the conclusion that under ordinary conditions, a body is neutral i.e. it exhibits no charge.

When this equity or balance is disturbed by removing or supplying electrons, the body acquires a net charge. The body will acquire a positive or negative charge depending upon whether electrons are removed from it or added to it.

◆ Types of Electric Charge

There are two types of charges:

- (i) Positive charge - A body having deficiency of electrons as compared to proton.
- (ii) Negative charge- A body having excess of electrons as compared to proton.

◆ Charging a body

There are a number of methods to charge a body as:

- Charging by friction
- Charging by conduction
- Charging by induction, etc.

◆ We will discuss charging by friction

Whenever two bodies (at least one non conductor) are rubbed against each other, heat is produced due to friction present between them. Due to this heat produced, electrons in both the bodies are excited. The body having more electron affinity attracts some of the electrons from other body. Both the bodies develop equal and opposite charges by this method.

POSITIVE CHARGE	NEGATIVE CHARGE
1. Glass Rod	1. Silk cloth
2. Fur or woolen cloth	2. Ebonite, Amber, Rubber rod
3. Woolen coat	3. Plastic seat
4. Woolen carpet	4. Rubber shoes
5. Nylon or Acetate	5. Cloth
6. Dry hair	6. Comb

Note: The object in above table must be in given pair.

◆ Properties of Electric Charge

- Like charges repel and unlike charges attract each other.
- Charge is a scalar quantity
- Charge is always quantized: The amount of charge on a charged body is always in integral multiple of the elementary charge and the fractional multiple is not possible.
- Charge is conserved.
- Charge is always associated with mass.
- Total charge of system remains conserved.

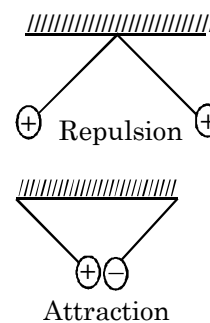

◆ Unit of Charge

The S.I. unit of charge is coulomb abbreviated as C. One coulomb of charge is equal to the charge on 625×10^{16} electrons.

1 coulomb = charge on 625×10^{16} electrons
or 6.25×10^{18} electrons

Thus, when we say that a body has a positive charge of one coulomb (i.e. + 1C) it means that the body has a deficit of 625×10^{16} electrons from the normal due to share.

Note: The attraction and repulsion of electric charges can be used in experiments to demonstrate the existence of two types of charge. Note that it is possible for a charged object to attract an uncharged object that is free to move but it cannot repel an uncharged object because it is neutral.

Ex.1 Calculate the number of electrons constituting one coulomb of charge.

Sol. Number of electrons constituting one coulomb of charge:-

From $q = ne$

$$n = \frac{q}{e} = \frac{1\text{C}}{1.6 \times 10^{-19}\text{C}} = 6.25 \times 10^{18} \text{ electrons}$$

Static and Current Electricity

◆ Static electricity

A branch of physics which deals with the study of the electric charges at rest and their effects is known as electrostatic or static electricity.

◆ Current electricity

A branch of physics which deals with the study of the electric charges in motion and their effects is known as current electricity.

COMPETITIVE LEVEL

Coulomb's Law

Charles Augustine De Coulomb studied the interaction forces of charged particles in detail in 1784. He used a torsion balance. On the basis of his experiments he established Coulomb's law. According to this law, the force of attraction or repulsion between two stationary point charges is directly proportional to the product of charges and inversely proportional to the square of distance between them. This force acts along the line joining the two. If q_1 & q_2 are charges in consideration, r , the distance between them and F , the force acting between them

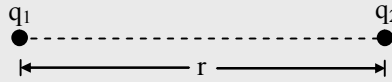

Then, $F \propto q_1 q_2$

$F \propto 1/r^2$

$$\therefore F \propto \frac{q_1 q_2}{r^2}$$

$\Rightarrow F = k \frac{q_1 q_2}{r^2}$, where $k = \text{constant}$.

$$K = \frac{1}{4\pi\epsilon_0\epsilon_r} = \frac{9 \times 10^9}{\epsilon_r} \text{ Nm}^2\text{C}^{-2}$$

Where,

$\epsilon_0 = \text{Electric permittivity of vacuum or air}$

$$= 8.85 \times 10^{-12} \text{ C}^2\text{N}^{-1} \text{ m}^{-2} \text{ and}$$

K or $\epsilon_r = \text{Relative permittivity or Dielectric constant}$

or Specific inductive capacity

$$\epsilon_r = \frac{\epsilon}{\epsilon_0} \Rightarrow \epsilon = \epsilon_0\epsilon_r$$

[Newton's law for particles is analogous to coulomb's law for rest charges. The difference is that Newton's law gives attraction force while coulomb's law gives attraction as well as repulsion force]

Direction: Direction of the force acting between two charges depends upon their nature and it is along the line joining two charges.

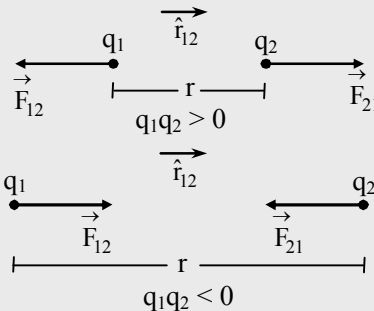

$$\vec{F}_{21} = \text{force on } q_2 \text{ due to } q_1 \quad \vec{F}_{21} = \frac{q_1 q_2}{4\pi\epsilon_0\epsilon_r r_{12}^2} \hat{r}_{12} \quad \dots\dots(A)$$

(where \hat{r}_{12} is a unit vector pointing from q_1 to q_2)

$\vec{F}_{12} = \text{Force on } q_1 \text{ due to } q_2$

$$\vec{F}_{12} = \frac{q_1 q_2}{4\pi\epsilon_0\epsilon_r r_{12}^2} \hat{r}_{21} \quad \dots\dots(B)$$

(where \hat{r}_{21} is a unit vector pointing from q_2 to q_1)

\Rightarrow Electric force between two charges does not depend on neighboring charges.

⇒ When two charges (Q_1, Q_2) are placed some distance apart. Neutral point is nearer to smaller charge, in between Q_1 and Q_2 if charges are like and away from charge if charges are unlike.

⇒ System of following charges is in equilibrium, if

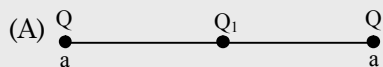

$$Q_1 = -\frac{Q}{4}$$

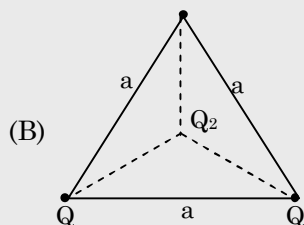

$$Q_2 = -\frac{Q}{\sqrt{3}}$$

⇒ For a three charge system it is not possible that all charges are in **stable** equilibrium.

⇒ Coulomb's law is similar to Newton's gravitation law.

⇒ If $F_g = F_e$ for two identical charges then,

$$\frac{q}{m} = \sqrt{4\pi\epsilon_0 G}$$

Ex.2 Ten charged particles are kept fixed on the X axis at point $x = 10$ mm, 20 mm, 30 mm, 100 mm. The first particle has a charge 10^{-8} C, the second 8×10^{-8} C, the third 27×10^{-8} C and so on. The tenth particle has a charge 1000×10^{-8} C. Find the magnitude of electric force acting on a 1 C charge placed at the origin.

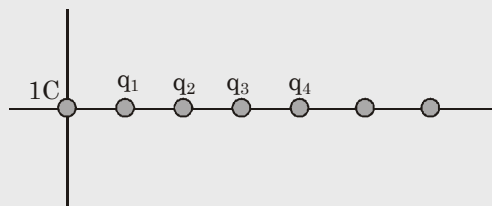

Sol. Force of 1C charge = $\frac{Kq_1 \times 1}{(10 \times 10^{-3})^2} + \frac{Kq_2 \times 1}{(20 \times 10^{-3})^2} + \frac{Kq_3 \times 1}{(30 \times 10^{-3})^2} + \dots$

$$= \frac{K \times 10^{-8}}{10^{-4}} \left[\frac{1^3}{1^2} + \frac{2^3}{2^2} + \frac{3^3}{3^2} + \dots + \frac{10^3}{10^2} \right] = 9 \times 10^9 \times 10^{-4} \times 55 = 4.95 \times 10^7 \text{ N.}$$

◆ Electric Field

Electric field due to a given charge is defined as the space around the charge in which electrostatic force of attraction or repulsion due to charge can be experienced by any other charge. If a test charge experiences no force at a point, the electric field at that point must be zero.

◆ Electric Field Intensity

Electric field intensity at any point is the strength of electric field at that point. It is defined as the force experienced by unit positive charge placed at that point.

If F is the force acting on a test charge $+q_0$ at any point then electric field intensity at this point is given by

$$E = \frac{F}{q_0}$$

Electric field intensity is a vector quantity and its S.I. unit is Newton per coulomb (N/C).

◆ Electric Field Strength due to Point Charge

As discussed earlier, if we find electric field due to a point charge at a distance x from it. Its magnitude can be given as

$$E = \frac{kq}{x^2}$$

Ex.3 What is the magnitude of a point charge due to which the electric field 30 cm away has the magnitude 2 *Newton/Coulomb* [$1/4 \pi \epsilon_0 = 9 \times 10^9 \text{ Nm}^2 \text{ C}^{-2}$]

Sol. By using $E = \frac{1}{4\pi\epsilon_0} \cdot \frac{Q}{r^2}$; $2 = 9 \times 10^9 \times \frac{Q}{(30 \times 10^{-2})^2} \Rightarrow Q = 2 \times 10^{-11} \text{ C}$

Ex.4 A particle of mass $9 \times 10^{-31} \text{ kg}$ and a negative charge of $1.6 \times 10^{-19} \text{ coulomb}$ projected horizontally with a velocity of 10^5 m/s into a region between two infinite horizontal parallel plates of metal. The distance between the plates is 0.3 cm and the particle enters 0.1 cm below the top plate. The top and bottom plates are connected respectively to the positive and negative terminals of a 30 volt battery. Find the component of velocity of the particle just before it hits one of the plates. (Given $E = V/d$)

Sol. We know that between two parallel plates electric field can be given as

$$E = \frac{V}{d}$$

Here $V = 30 \text{ volt}$ and $d = 0.3 \text{ cm} = 3 \times 10^{-3} \text{ m}$

Thus, we have $E = \frac{30}{3 \times 10^{-3}} = 10^4 \text{ N/C}$

Force on the particle of negative charge moving between the plates

$$F = e \times E = 1.6 \times 10^{-19} \times 10^4 = 1.6 \times 10^{-15} \text{ N.}$$

The direction of force will be towards the positive plate i.e., upward.

Now, acceleration of the particle is

$$a = \frac{eE}{m}$$

or $a = (1.6 \times 10^{-15}) / (9 \times 10^{-31})$

or $a = 1.77 \times 10^{15} \text{ m/sec}^2$

As the electric field intensity E is acting in the vertical direction, the horizontal velocity v of the particle remains same. If y is the displacement of the particle in upward direction, we have

$$y = \frac{1}{2} at^2$$

Here, $y = 0.1 \text{ cm} = 10^{-3} \text{ m}$, $a = 1.77 \times 10^{15} \text{ m/sec}^2$

$$\text{Thus } 10^{-3} = \frac{1}{2} \times (1.77 \times 10^{15}) (t^2)$$

Solving, we get $t = 1.063 \times 10^{-9}$ second

Component of velocity in the direction of field is given by,

$$\begin{aligned} v_y &= at \\ &= (1.77 \times 10^{15}) (1.063 \times 10^{-10}) \\ &= 1.881 \times 10^6 \text{ m/s.} \end{aligned}$$

Electric Potential and Potential Difference

The flow of electricity in a circuit can be regarded very much similar to the flow of water in a pipe. The water pipe is analogous to the electric conductor, while the amount of water flowing through a given point per second corresponds to electric current. Figure below shows how the pump (P) builds up and maintains pressure by lifting water from a tank (B) to the reservoir (A) through the pipe (R). Note that along the pipe, different points are at different pressure. Water in the pipe flow from, say point C to point D, only when the pressure at C is greater than that at D. Thus, when the valve (V) is open, water would start flowing into the reservoir.

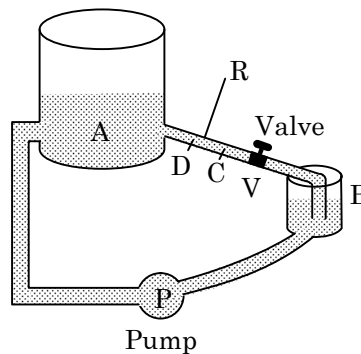

In the same manner electrons will move along a wire only if there is a difference of electric pressure called potential difference along the conductor. This difference of potential is produced by the cell or a battery, which acts like a water pump in the circuit.

The chemical action within the cell generates the difference in potential between the electrodes, which sets the electrons in motion and produces the current.

Electric Potential: Work done in bringing a unit positive charge from infinity to any point in an electric field of another charge is termed as potential at that point i.e. if,

$$W = \text{work done in bringing a positive charge } q_0 \text{ from infinity to that point, then, } V = \frac{W}{q_0}$$

Since work is measured in joule and charge in coulomb, therefore electric potential is measured in joule per coulomb (J/C).

Joule per coulomb occurs so often in our study of electricity, so it has been named as volt, in honour of the scientist Alessandra Volta (the inventor of the voltaic cell).

$$1 \text{ Volt} = \frac{1 \text{ joule}}{1 \text{ coulomb}}$$

Potential is a scalar quantity, therefore it is added algebraically. For a positively charged body potential is positive and for a negatively charged body potential is negative.

- We can say potential is the electrical state of a conductor which determines the direction of flow of charge when the two conductors are kept in contact.

Some Important Points

- (i) Electric potential at infinity is taken to be zero.
- (ii) It is not path dependent quantity, it simply depends upon the starting and end points.
- (iii) It is a scalar quantity.
- (iv) Unit: Volt or Joule/Coulomb
- (v) Dimension: $[M^1 L^2 T^{-3} A^{-1}]$
- (vi) Potential due to a positive charge is positive and potential due to a negative charge is negative. Here, potential being positive and negative implies whether work is done on the charge or done by the charge respectively.
- (vii) Potential due to a point charge Q at a distance r is

$$V = \frac{1}{4\pi\epsilon_0} \frac{q}{r} \Rightarrow V \propto \frac{1}{r}$$

- (viii) Total potential at a point due to a group of charges is scalar sum of individual potentials

$$V_p = V_1 + V_2 + \dots + V_n$$

- (ix) Electric field is gradient of electric potential at that point.

$$E = - \frac{dv}{dr}$$

Note: The negative sign implies that direction of electric field is in the direction of decreasing potential.

- (x) Potential of earth is taken to be zero.

Potential difference: The work done in taking a charge from one point to the other in an electric field is called the potential difference between two points.

Thus, if W be work done in moving a charge q_0 from B to A then the potential difference is given by-

$$V_A - V_B = \frac{W}{q_0}$$

Note: Do not confuse e.m.f. and potential difference (V), even though they have the same units. E.m.f., ϵ , is provided by a source of electrical energy, but potential difference (V) refers to the electrical energy converted to other forms by a circuit component.

Electric Potential Energy

Consider a charge Q placed at a point P as shown in figure. If another charge q of the same sign is now brought from a very far away distance (infinity) to point O near P, then charge q will experience a force of repulsion due to charge Q . If charge q is still pushed towards P, work is done. This work done is the potential energy of the system of these two charges.

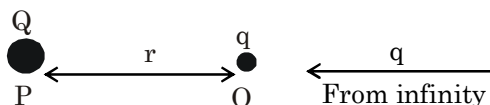

Thus, the electric potential energy of a system of charges is defined as the amount of work done in bringing the various charges from infinite separation to their present positions to form the required system. It is denoted by U . For the system of two charges separated by distance r as shown in figure, the electric potential energy is given by:

$$U = \frac{kQq}{r}$$

Electric potential energy is the form of energy, therefore, it is measured in joule (J). The potential difference is measured by means of an instrument called voltmeter. The voltmeter is connected in parallel across the points where the potential difference is to be measured. A voltmeter has a high resistance so that it takes a negligible current from the circuit.

Work done in bringing a charge Q from infinity to that point is,

$$W = QV$$

Where, V is potential at that point.

Ex.5 How much energy is given to each coulomb of charge passing through a 6 V battery?

Sol. Energy required to each coulomb of charge passing through a 6 V battery is $U = VQ = 6 \text{ V} \times 1 \text{ C} = 6 \text{ J}$.

Ex.6 What is meant by saying that the potential difference between two points is 1 V?

Sol. If 1 Joule of work is required to move charge of 1C from one point to another, then it is said that the potential difference between the two points is 1V.

Ex.7 Name a device that helps to maintain a potential difference across a conductor. How it helps to maintain the current in a given electric circuit? What energy changes takes place in it?

Sol. To maintain a potential difference across a conductor we use a device known as cell. The chemical action within a cell generates the potential difference across the terminals of the cell, even when no current is drawn from it. When the cell is connected to a conducting circuit element, the potential difference sets the charges in motion in the conductor and produces an electric current. In order to maintain the current in a given electric circuit, the cell has to expend its chemical energy stored in it hence cell converts chemical energy into electrical energy to move charges in electric circuit.

Electric Current & Circuits

◆ Charges in motion

When two charged bodies at different potentials are connected by a conducting wire, electrons flow from the body at lower potential to the one at higher potential till the potentials of both the bodies become equal i.e., potential difference between the two bodies becomes zero. Figure below, shows the two oppositely charged conductors A and B which are held on stands. The positively charged conductor A is said to be at higher potential and the negatively charged conductor B is said to be at lower potential.

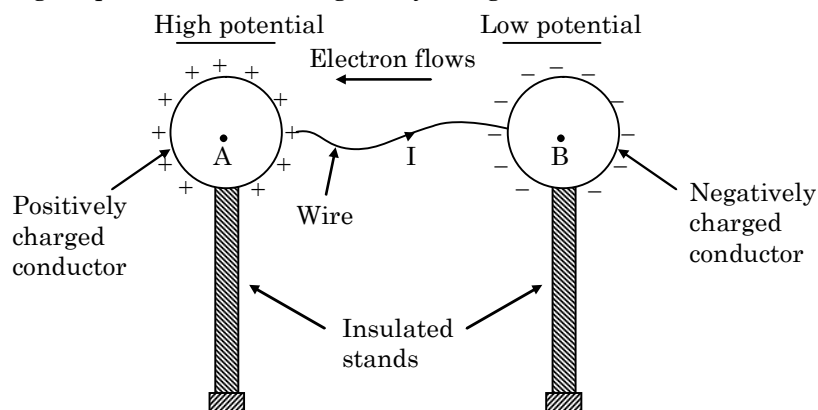

It means that there exists a potential difference between the conductors A and B. Therefore, on joining positively charged conductor A to negatively charged conductor B, negative charge starts flowing from conductor B to conductor A. Flow of charge will stop when both the conductors A and B acquire the same potential.

This rate of flow electric charge from one body to another through a conductor such as metal wire is called electric current and its direction is opposite to direction of flow of electrons.

Or

The quantity of charge passing through a given point of the conductor in one second is called electric current.

Thus, if Q is the charge which flows through a conductor in time t, then the electric current is given by

$$\text{Current (I)} = \frac{\text{Charge(Q)}}{\text{Time(t)}}$$

or
$$I = \frac{(Q)}{(t)}$$

or
$$Q = It$$

Note: *The electric current is a scalar quantity.*

◆ Unit of Current

S.I. unit of current is ampere, which is denoted by letter A.

Current is said to be one ampere if one coulomb of charge flows through any cross section of a conductor in one second, i.e.

$$1 \text{ ampere} = \frac{1 \text{ coulomb}}{1 \text{ second}} \quad \text{or} \quad 1 \text{ A} = 1 \text{ C s}^{-1}$$

◆ Smaller Units of Current

$$1 \text{ milliampere (mA)} = 10^{-3} \text{ A}$$

$$1 \text{ microampere (A)} = 10^{-6} \text{ A}$$

◆ Direction of Electric Current

When electricity was invented a long time back, it was known that there are two types of charges: positive charges and negative charges, but the electron had not been discovered at that time. So, electric current was considered to be a flow of positive charges and the direction of flow of the positive charges was taken to be the direction of electric current. Thus, the conventional direction of electric current is from positive terminal of a cell (or battery) to the negative terminal through the circuit.

◆ How the Current Flows in a Wire

As electric current is the flow of electrons in a metal wire (or conductor) when a cell or battery is connected across its ends. A metal wire has plenty of free electrons in it. When the metal wire has not been connected to a source of electricity like a cell or a battery, then the electrons present in it move at random in all the directions between the atoms of the metal wire as shown in figure below.

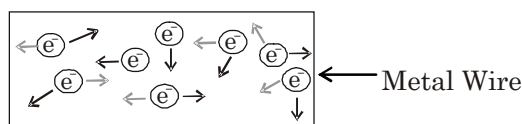

When a source of electricity like a cell or a battery is connected between the ends of the metal wire, then an electric force acts on the electrons present in the wire. Since the electrons are negatively charged, they start moving from negative end to the positive end of the wire and this flow of electrons constitutes the electric current in the wire.

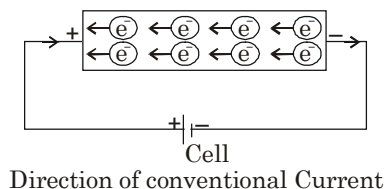

Note: Electric eel fish can generate around 600V and 1 ampere of current through the water it uses this capacity to electrocute and kill its prey.

◆ **How to get a Continuous Flow of Electric Current**

It is due to the potential difference between two points that an electric current flows between them. The simplest way to maintain a potential difference between the two ends of a conductor so as to get a continuous flow of current is to connect the conductor between the terminals of a cell or a battery. Due to the chemical reactions going on inside the cell or battery, a potential difference is maintained between its terminals and this potential difference drives the current in a circuit.

Ex.8 If 'q' coulombs of charge travel through a conductor of length 'ℓ' m with a velocity of 'v' m/s, what is the current flowing through the conductor?

Sol. Charge passing through the conductor = 'q' coulomb

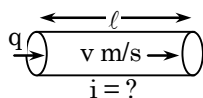

We know that current, $i = \frac{q}{t}$ (i)

and speed, $v = \frac{\ell}{t} \Rightarrow t = \frac{\ell}{v}$

Substituting the value of 't' in equation (i)

We get $i = \frac{q}{t} = \frac{q}{\left(\frac{\ell}{v}\right)} = \frac{q \times v}{\ell}$

∴ The current flowing through conductor = qv/ℓ

Ex.9 An electron of charge 'e' C moves in a circular orbit at a frequency of 'n' revolution per second. Then find the strength of the current.

Sol. Let P be a reference point in the orbit

$$i = \text{rate of flow charge} = \frac{q}{t}$$

Consider, $t = 1\text{ s}$



In 1 second the electron completes 'n' revolutions (frequency is 'n' rev/s)

⇒ In 1 second the electron passes through 'P' for 'n' times.

∴ charge through 'P' in 1 second (q) = ne, where 'e' is charge of electron.

$$\therefore i = \frac{q}{t} = \frac{ne}{1} = ne \text{ (amp.)}$$

Electric circuit

A continuous path consisting of conducting wires and other components (like lamps, bulbs etc.) between the terminals of a battery, along which an electric current flows, is called a circuit.

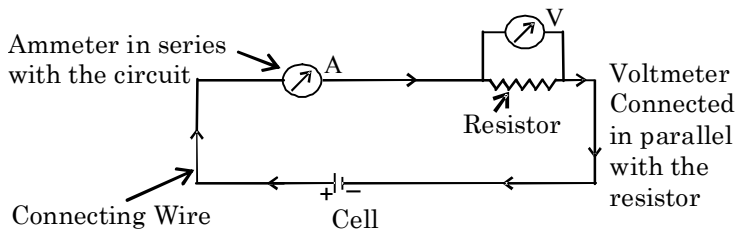

◆ Open Electric Circuit

An electric circuit through which no electric current flows is known as open electric circuit. The electric circuit will be open circuit if the plug of the key is taken out or if the connecting wires break from any point.

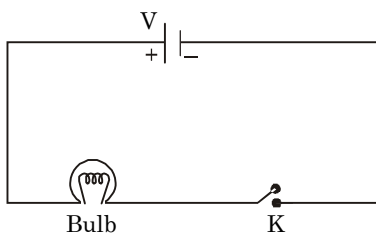

◆ Closed Circuit

An electric circuit through which electric current flows continuously is known as closed circuit.

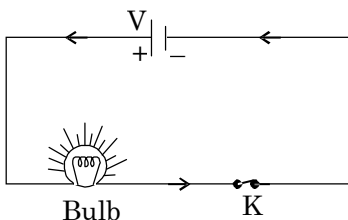

Electric Symbols

The various electrical symbols used in electric circuits are given below:

S.N	Components	Symbols
1.	Electric cell	
2.	Battery	
3.	Plug key (switch open)	
4.	Plug key (switch closed)	
5.	A wire joint	
6.	Wires crossing without joining	
7.	Electric bulb	
8.	A resistor of resistance R	
9.	Variable resistance or rheostat	
10.	Ammeter	
11.	Voltmeter	
12.	Fuse	

Ex.10 What does an electric circuit mean?

Sol. A continuous and closed path of an electric current is called an electric circuit.

Ex.11 Define SI unit of electric current.

Sol. SI unit of electric current is ampere. One ampere is current constituted by the flow of one coulomb of charge per second, that is, $1A = 1 C/1 s$.

Ohm's Law

It states that the current passing through a conductor is directly proportional to the potential difference across its ends, provided the temperature and other physical conditions (mechanical strain etc.), remain unchanged

$$\text{i.e., } I \propto V$$

$$V \propto I$$

$$V = RI$$

where R is a constant called resistance of the conductor.

The relation $R = V/I$ is referred to as Ohm's law, after the German physicist George Simon Ohm (1789 - 1854), who discovered it.

It is quite clear from the above equation that

- The current I is proportional to the potential difference V between the ends of the resistor.
- If V is constant, then current I is inversely proportional to the resistance.

◆ **Experimental Verification of Ohm's Law**

Set up a circuit as shown in the figure below consisting of a wire AB, a current measuring instrument called ammeter, an instrument measuring the potential difference called voltmeter and a number of cells, each of which provides some constant potential difference across the two points of a conductor. First, use one cell and note the current in the circuit and the potential difference across the wire AB. Suppose the cell produces a current I in the circuit and a potential difference (V) across the wire AB. Repeat this experiment with two cells, three cells and four cells.

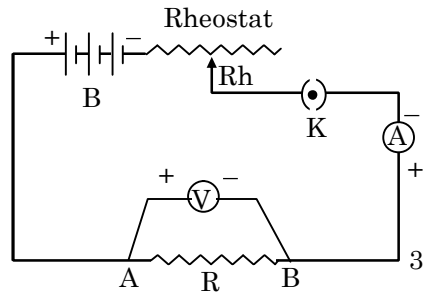

Note the successive readings in the ammeter and the voltmeter. We will find that with two cells in the circuit, the current would be $2I$ and the potential difference $2V$. Similarly, with three cells the current is $3I$ and potential difference $3V$ and so on. [The important precaution to observe here is not to allow the current to flow in the wire continuously. This can be done by taking off the plug key and closing it only when the current is to be drawn.]

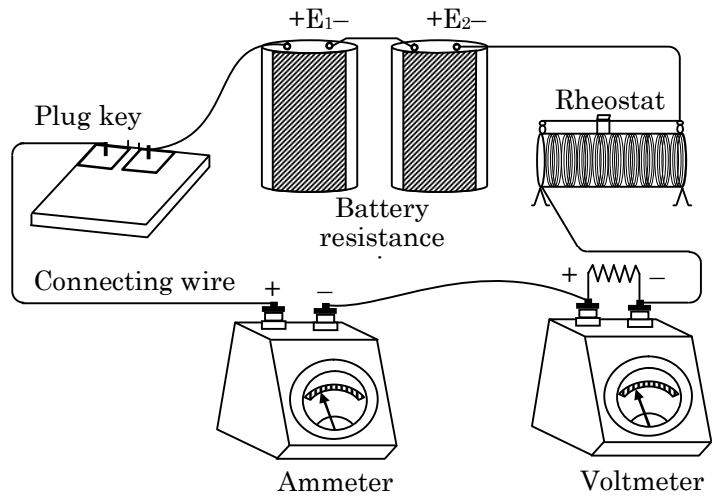

Experimental setup for verification of Ohm's law

◆ **Results of Ohm's Law**

- Current flowing through a conductor is directly proportional to the potential difference across the conductor

$$I \propto V$$

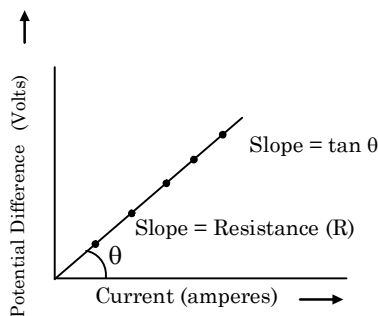

- When the potential difference in a circuit is kept constant, the current is inversely proportional to the resistance of the conductor.

$$I \propto 1/R$$

- The ratio of potential difference to the current is constant. The value of the constant is equal to the resistance of the conductor (or resistor).

$$V/I = R$$

Resistance of a Conductor

The electric current is a flow of electrons through a conductor. When the electrons move from one part of the conductor to the other part, they collide with other electrons and with the atoms and ions present in the body of the conductor. Due to these collisions, there is some obstruction or opposition to the flow of electrons through the conductor.

The property of a conductor due to which it opposes the flow of current through it, is called resistance. The resistance of a conductor is numerically equal to the ratio of potential difference across its ends to the current flowing through it.

$$\Rightarrow \text{Resistance} = \frac{\text{Potential difference}}{\text{Current}}$$

$$\text{or } R = \frac{V}{I}$$

Slope of graph-

$$\tan\theta = \frac{V}{I} = R$$

- Unit of Resistance

The S.I. unit of resistance is ohm, which is denoted by the symbol Ω . When a potential difference of 1 volt is applied to the ends of the conductor and a current of 1 ampere flows through it, then resistance of the conductor will be 1 ohm.

◆ **Conductors, Resistors and Insulators**

On the basis of their electrical resistance, all the substances can be divided into three groups: conductors, resistors and insulators.

- *Conductors*: Those substances which have very low electrical resistance are called conductors. A conductor allows the electricity to flow through it easily. Silver metal is the best conductor of electricity. Copper and aluminium metals are also good conductors. Electric wires are made of copper or aluminium because they have very low electrical resistance.
- *Resistors* : Those substances which have comparatively high electrical resistance, are called resistors. The alloys like nichrome, manganin and constantan (or ureka), all have quite high resistances, so they are used to make those electrical devices where high resistance is required. A resistor reduces the current in the circuit.
- *Insulators*: Those substances which have infinitely high electrical resistance are called insulators. An insulator does not allow electricity to flow through it. Rubber is an excellent insulator. Electricians wear rubber handgloves while working with electricity because rubber is an insulator and protects them from electric shocks. Wood is also a good insulator.

◆ Factors affecting the Resistance of a Conductor

Resistance depends upon the following factors:

- (i) Length of the conductor.
- (ii) Area of cross-section of the conductor (or thickness of the conductor).
- (iii) Nature of the material of the conductor.
- (iv) Temperature of the conductor.

◆ Mathematical Expression of Resistance

It has been found by experiments that

- (i) The resistance of a given conductor is directly proportional to its length i.e.

$$R \propto L \quad \text{.....(i)}$$

- (ii) The resistance of a given conductor is inversely proportional to its area of cross-section i.e.

$$R \propto \frac{1}{A} \quad \text{.....(ii)}$$

from (i) and (ii)

$$R \propto \frac{L}{A} \quad \Rightarrow \quad R = \frac{\rho \times L}{A} \quad \text{.....(iii)}$$

where, ρ (rho) is a constant known as resistivity of the material of the conductor. Resistivity is also known as specific resistance.

Ex.12 Will current flow more easily through a thick wire or a thin wire of the same material, when connected to the same source? Why?

Sol. Resistance of a wire is given by the relation, $R = \frac{\rho \ell}{A}$ From above equation we can see that resistance is inversely proportional to the area of cross-section of the wire. Thick wire means more area of cross-section and lower the resistance of wire. Similarly, thin wire means less area of cross-section and wire would have higher resistance. Therefore, current can flow more easily through thick wire than a thin wire.

Ex.13 On what factors does the resistance of a conductor depend?

Sol. The resistance of a conductor depends on following factors-
Material of the conductor
Temperature of the conductor
Length of the conductor
Area of cross-section of the conductor

Ex.14 Let the resistance of an electrical component remains constant while the potential difference across the two ends of the component decreases to half of its former value. What change will occur in the current through it?

Sol. From Ohm's Law we have $V = IR$. Now according to question the resistance of an electrical component remains constant while the potential difference across the two ends of the component decreases to half of its former value. So, we now have V is directly proportional to I .

Therefore, the amount of current flowing through the electric component is reduced to half.

COMPETITIVE LEVEL

◆ **Dependency of a Resistance on Temperature**

If R_0 is the resistance of the conductor at 0°C and R_t is the resistance of the conductor at $t^\circ\text{C}$ then the relation between R_0 and R_t is given by,

$$R_t = R_0(1 + \alpha\Delta t) \quad [\text{Here } \Delta t = t - 0 = t]$$

$$\text{or } \alpha = \frac{R_t - R_0}{R_0 t}$$

Here, α = Temperature Coefficient of Resistance, (SI unit = $^\circ\text{C}^{-1}$)

t = temperature in $^\circ\text{C}$

Ex.15 Temperature coefficient of resistance is 0.00125 per $^\circ\text{C}$. Resistance at 300K is 1Ω . What will be the temperature in (K) when resistance becomes 2Ω ?

Sol.
$$\alpha = \frac{R_2 - R_1}{R_1 t_2 - R_2 t_1}$$

$$\Rightarrow 0.00125 = \frac{2 - 1}{1 \times t_2 - 2 \times 27} \quad [t_1 = 300 \text{ K} = 27^\circ\text{C}]$$

$$\Rightarrow t_2 = 854^\circ\text{C}$$

$$t_2 = 1127 \text{ K}$$

◆ **Resistivity**

$$\rho = \frac{R \times A}{L}$$

By using this formula, we will now obtain the definition of resistivity. Let us take a conductor having a unit area of cross-section of 1 m^2 and a unit length of 1 m. So, putting $A = 1$ and $L = 1$ in above equation we get:

Resistivity, $\rho = R$

- **Definition of resistivity:** The resistivity of a substance is numerically equal to the resistance of a rod of that substance which is 1 metre long and 1 metre square in cross-section.

Unit of resistivity,

$$\rho = \frac{\text{ohm} \times (\text{metre})^2}{\text{metre}} = \text{ohm} \cdot \text{metre}$$

The S.I. unit of resistivity is ohm-metre which is written in symbols as $\Omega\cdot\text{m}$. Resistivity of a substance does not depend on its length or thickness. It depends only on the nature of the substance. The resistivity of a substance is its characteristic property. So, we can use the resistivity to compare the resistances of two or more substances.

- **Importance of resistivity:** A good conductor of electricity should have a low resistivity and a poor conductor of electricity should have a high resistivity. The resistivity of alloy are much more higher than those of the pure metals.

It is due to their high resistivities that manganin and constantan alloys are used to make resistance wires used in electronic appliances to reduce the current in an electrical circuit.

Nichrome alloy is used for making the heating elements of electrical appliances like electric irons, room-heaters, water-heaters and toasters etc. because it has very high resistivity and it does not undergo oxidation (or burn) even when red-hot.

COMPETITIVE LEVEL

- **Effect of temperature on resistivity:** The resistivity of conductors (like metals) is very low. The resistivity of most of the metals increases with temperature. On the other hand, the resistivity of semi-conductors like silicon and germanium is in between those of conductors and insulators and decreases on increasing the temperature. Semi-conductors are proving to be of great practical importance because of their marked change in conducting properties with temperature and impurity concentration.

Ex.16 Why alloys do not oxidise (burn) readily at high temperature?

Sol. Because with the change in temperature their resistivity changes less rapidly.

Ex.17 Find the specific resistance of a wire of length 1.1m, 0.4 mm in diameter and having a total resistance of 4.2Ω.

Sol. $\because R = \frac{\rho \ell}{A} \Rightarrow \rho = \frac{RA}{\ell} \qquad \frac{RA}{\ell} = \frac{4.2 \times \pi d^2}{1.1 \times 4}$

Here $A = \pi r^2$ and $r = \frac{d}{2}$, $d = 0.4 \times 10^{-3} \text{m}$

$\therefore \rho = 48 \times 10^{-8} \Omega \text{ metre.}$

Ex.18 A wire of resistance 4 Ω is redrawn by pulling it doubled, what is its new resistance?

Sol. Let L is the length of the wire before stretching, L' is the length of the wire after stretching, A is the area of the wire before stretching, A' is the area of the wire after stretching, R is the resistance of the wire before stretching,, R' is the resistance of the wire after stretching.

Since the volume of the wire remains constant,

$\therefore AL = A'L'$

$\Rightarrow L' = 2L$

So, $A' = \frac{AL}{L'} = \frac{AL}{2L} = \frac{A}{2}$

$\Rightarrow \frac{R'}{R} = \frac{\rho L'}{A'} \times \frac{A}{L} = \frac{A}{A} \times \frac{L'}{L} = \frac{A}{A/2} \times \frac{2L}{L}$

So, $\frac{R'}{R} = 4$

$R' = 4R$

$R = 4\Omega$

Hence $R' = 4 \times 4 = 16 \Omega .$

Combination of Resistances

◆ Series Combination

When two or more resistances are joined end-to-end so that the same current flows through each of them, they are said to be connected in series.

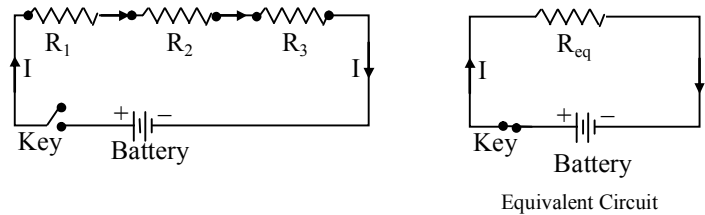

When a series combination of resistances is connected to a battery, the same current (I) flows through each of them.

- **Law of combination of resistances in series:** The law of combination of resistances in series states that when a number of resistances are connected in series, their equivalent resistance is equal to the sum of the individual resistances. Thus, if R_1 , R_2 , R_3 ..., etc. are combined in series, then the equivalent resistance (R) is given by,

$$R = R_1 + R_2 + R_3 + \dots \quad \dots(i)$$

- **Derivation of mathematical expression of resistances in series combination:** Let R_1 , R_2 and R_3 be the resistances connected in series, I be the current flowing through the circuit, i.e., passing through each resistance, and V_1 , V_2 and V_3 be the potential difference across R_1 , R_2 and R_3 , respectively. Then, from Ohm's law,

$$V_1 = IR_1, V_2 = IR_2 \text{ and } V_3 = IR_3 \quad \dots(ii)$$

If V is the potential difference across the combination of resistances then,

$$V = V_1 + V_2 + V_3 \quad \dots(iii)$$

If R is the equivalent resistance of the circuit, then

$$V = IR \quad \dots(iv)$$

Using Eqs. (i) to (iv) we can write,

$$\begin{aligned} IR &= V = V_1 + V_2 + V_3 \\ &= IR_1 + IR_2 + IR_3 \end{aligned}$$

or, $IR = I(R_1 + R_2 + R_3)$

or, $R = R_1 + R_2 + R_3$

Therefore, when resistances are combined in series, the equivalent resistance is higher than each individual resistance.

- **Some results about series combination:**

- (i) When two or more resistors are connected in series, the total resistance of the combination is equal to the sum of all the individual resistances.
- (ii) When two or more resistors are connected in series, the same current flows through each resistor.
- (iii) When a number of resistors are connected in series, the voltage across the combination (i.e. voltage of the battery in the circuit), is equal to the sum of the voltage drop (or potential difference) across each individual resistor.

(iv) $R_{eq} > R_{max}$

◆ Parallel Combination

When two or more resistances are connected between two common points so that the same potential difference is applied across each of them, they are said to be connected in parallel.

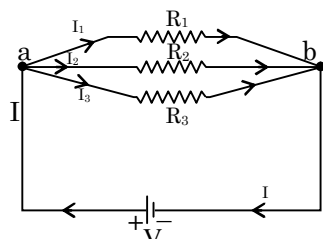

Parallel Circuit

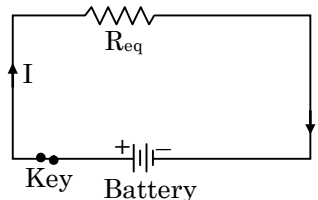

Equivalent Circuit of Parallel Combination

When such a combination of resistance is connected to a battery, all the resistances have the same potential difference across their ends.

• Derivation of mathematical expression of parallel combination:

Let V be the potential difference across the two common points A and B. Then, from Ohm's law

$$\text{Current passing through } R_1, I_1 = V/R_1 \quad \dots(i)$$

$$\text{Current passing through } R_2, I_2 = V/R_2 \quad \dots(ii)$$

$$\text{Current passing through } R_3, I_3 = V/R_3 \quad \dots(iii)$$

If R is the equivalent resistance, then from Ohm's law, the total current flowing through the circuit is given by,

$$I = V/R \quad \dots(iv)$$

$$\text{and } I = I_1 + I_2 + I_3 \quad \dots(v)$$

Substituting the values of I , I_1 , I_2 and I_3 in eq. (v),

$$\frac{V}{R} = \frac{V}{R_1} + \frac{V}{R_2} + \frac{V}{R_3} \quad \dots(vi)$$

Cancelling common V term, one gets

$$\frac{1}{R} = \frac{1}{R_1} + \frac{1}{R_2} + \frac{1}{R_3}$$

The equivalent resistance of a parallel combination of resistance is less than each of all the individual resistances.

• Important results about parallel combination:

- (i) Total current through the circuit is equal to the sum of the currents flowing through it.
- (ii) In a parallel combination of resistors the voltage (or potential difference) across each resistor is the same and is equal to the applied voltage i.e. $V_1 = V_2 = V_3 = V$
- (iii) Current flowing through each resistor is inversely proportional to its resistances, thus higher the resistance of a resistor, lower will be the current flowing through it.
- (iv) $R_{eq} < R_{min}$

Ex.19 Draw a schematic diagram of a circuit consisting of a battery of three cells of 2 V each, a 5Ω, 8Ω and 12Ω resistors, and a plug key, all connected in series.

Sol. Three cells of potential 2 V, each one of these cells are connected in series therefore the potential difference of the combined battery will be $2\text{ V} + 2\text{ V} + 2\text{ V} = 6\text{ V}$. The following circuit diagram shows three resistors of resistances 5Ω, 8Ω and 12Ω respectively connected in series and a battery of potential 6 V and a plug key which is closed means the current is flowing in the circuit.

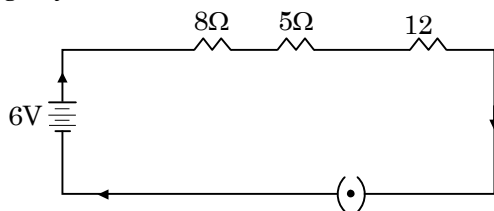

Ex.20 Redraw the circuit of above question, putting in an ammeter to measure the current through the resistors and a voltmeter to measure the potential difference across the 12Ω resistor. What would be the readings in the ammeter and the voltmeter?

Sol.

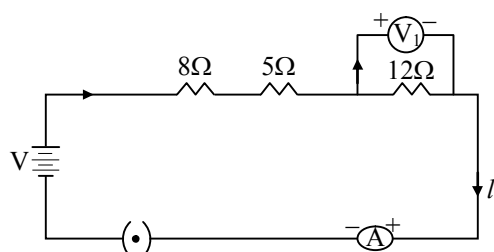

According to Ohm's law,

$$V = IR,$$

Now Potential difference (V) = 6 V

Let current flowing through the circuit = I

Resistance of the circuit, $R = 5 + 8 + 12 = 25\ \Omega$

Since $I = V/R$

$$= 6 / 25$$

$$= 0.24\ \text{A}$$

Potential difference across 12Ω resistor = V_1

Current flowing through the 12Ω resistor, $I = 0.24\ \text{A}$

Therefore, using Ohm's law, we obtain

$$V_1 = IR$$

$$= 0.24 \times 12 = 2.88\ \text{V}$$

Therefore, the reading of the ammeter will be 0.24 A.

And the reading of the voltmeter will be 2.88 V.

Ex.21 Judge the equivalent resistance when the following are connected in parallel –

(a) 1Ω and $10^6\ \Omega$

(b) 1Ω, $10^3\ \Omega$ and $10^6\ \Omega$.

Sol. (a) Since 1Ω and $10^6\ \Omega$ are connected in parallel then the equivalent resistance R will be

$$\frac{1}{R} = \frac{1}{1} + \frac{1}{10^6}$$

$$\Rightarrow R = \frac{10^6}{10^6 + 1} = \frac{10^6}{10^6} = 1 \Omega$$

\therefore Equivalent resistance is 1Ω

(b) 1Ω and $10^3 \Omega$ and $10^6 \Omega$ are in parallel

$$\frac{1}{R} = \frac{1}{1} + \frac{1}{10^3} + \frac{1}{10^6}$$

$$\frac{1}{R} = \frac{10^6 + 10^3 + 1}{10^6}$$

$$\frac{1}{R} = \frac{1001001}{1000000} \Rightarrow R = 0.999 \Omega$$

Therefore, equivalent resistance = 0.999Ω

Ex.22 An electric lamp of 100Ω , a toaster of resistance 50Ω , and a water filter of resistance 500Ω are connected in parallel to a 220 V source. What is the resistance of an electric iron connected to the same source that takes as much current as all three appliances, and what is the current through it?

Sol. Resistance of electric lamp (R_1) = 100Ω

Resistance of toaster (R_2) = 50Ω

Resistance of water filter (R_3) = 500Ω

Potential difference of the source, $V = 220 \text{ V}$

Since all the resistances are in parallel then the equivalent resistance R of the circuit will be

$$\begin{aligned} \frac{1}{R} &= \frac{1}{R_1} + \frac{1}{R_2} + \frac{1}{R_3} = \frac{1}{100} + \frac{1}{50} + \frac{1}{500} \\ &= \frac{5 + 10 + 1}{500} = \frac{16}{500} \end{aligned}$$

$$R = \frac{500}{16}$$

According to Ohm's law

$$I = \frac{V}{R}$$

Where current flowing through the circuit = I

$$I = \frac{220}{\frac{500}{16}} = \frac{220 \times 16}{500} = 7.04 \text{ A}$$

All the three given appliances are drawing 7.04 A of current.

Therefore, current drawn by an electric iron connected to the same source of potential $220 \text{ V} = 7.04 \text{ A}$

Let R' be the resistance of the electric iron. According to Ohm's law,

$$V = IR$$

$$R' = \frac{V}{I} = \frac{220}{7.04} = 31.25 \Omega$$

Therefore, the resistance of the electric iron is 31.25Ω and the current flowing through it is 7.04 A .

Ex.23 What are the advantages of connecting electrical devices in parallel with the battery instead of connecting them in series?

- Sol.** (i) Potential difference across each device remains the same whereas in series connection, it gets distributed.
(ii) If one device is switched off, it does not affect the other devices.

Ex.24 How can three resistors of resistances $2\ \Omega$, $3\ \Omega$, and $6\ \Omega$ be connected to give a total resistance of (a) $4\ \Omega$, (b) $1\ \Omega$?

Sol. There are three resistors of resistances $2\ \Omega$, $3\ \Omega$, and $6\ \Omega$ respectively.

(a) The following circuit diagram shows the connection of the three resistors.

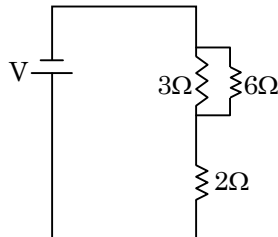

Here, $6\ \Omega$ and $3\ \Omega$ resistors are connected in parallel. Therefore, their equivalent resistance will be given by

$$\frac{1}{\frac{1}{6} + \frac{1}{3}} = \frac{6 \times 3}{6 + 3} = 2\ \Omega$$

This equivalent resistor of resistance $2\ \Omega$ is connected to a $2\ \Omega$ resistor in series. Therefore, equivalent resistance of the circuit = $2\ \Omega + 2\ \Omega = 4\ \Omega$

Hence, the total resistance of the circuit is $4\ \Omega$.

Ex.25 What is (a) the highest (b) the lowest total resistance that can be secured by combinations of four coils of resistances $4\ \Omega$, $8\ \Omega$, $12\ \Omega$, $24\ \Omega$?

Sol. Given resistances $R_1 = 4\ \Omega$, $R_2 = 8\ \Omega$, $R_3 = 12\ \Omega$ and $R_4 = 24\ \Omega$.

(a) If these coils are connected in series, then the equivalent resistance will be the highest, as

$$R = R_1 + R_2 + R_3 + R_4 \\ = 4 + 8 + 12 + 24 = 48\ \Omega$$

$\therefore 48\ \Omega$ is the highest resistance

(b) If these coils are connected in parallel to each other, then the equivalent resistance will be the lowest as,

$$\frac{1}{R} = \frac{1}{R_1} + \frac{1}{R_2} + \frac{1}{R_3} \\ \frac{1}{R} = \frac{1}{4} + \frac{1}{8} + \frac{1}{12} + \frac{1}{24} \\ \frac{1}{R} = \frac{6 + 3 + 2 + 1}{24} \Rightarrow \frac{1}{R} = \frac{12}{24} = \frac{1}{2}$$

$$\Rightarrow R = 2\ \Omega$$

$\therefore 2\ \Omega$ is the lowest total resistance.

Ex.26 If four resistances each of values 1 ohm are connected in series. Calculate the equivalent resistance.

Sol. In series,

$$R_1 = R_2 = R_3 = R_4 = 1 \text{ ohm}$$

putting values, we get,

$$R_s = 1 + 1 + 1 + 1 = 4 \Omega$$

Ex.27 Resistors R_1 , R_2 and R_3 having values 5Ω , 10Ω , and 30Ω respectively are connected in parallel across a battery of 12 volt. Calculate (a) the current through each resistor (b) the total current in the circuit and (c) the total circuit resistance.

Sol. Here,

$$R_1 = 5\Omega, \quad R_2 = 10\Omega, \quad R_3 = 30 \Omega, \quad V = 12 \text{ V}$$

$$I_1 = ?, \quad I_2 = ?, \quad I_3 = ?$$

$$I = I_1 + I_2 + I_3 = ?$$

$$R_p = ?$$

(a) From relation, (Ohm's law), $R = \frac{V}{I} \Rightarrow I = \frac{V}{R}$

Putting values, we get, $I_1 = \frac{V}{R_1} = \frac{12}{5} = 2.4 \text{ A}$

$$I_2 = \frac{V}{R_2} = \frac{12}{10} = 1.2 \text{ A}$$

$$I_3 = \frac{V}{R_3} = \frac{12}{30} = 0.4 \text{ A}$$

(b) Total current, $I = I_1 + I_2 + I_3$

$$I = 2.4 + 1.2 + 0.4 = 4 \text{ A}$$

(c) From relation $\frac{1}{R_p} = \frac{1}{R_1} + \frac{1}{R_2} + \frac{1}{R_3}$

$$\frac{1}{R_p} = \frac{1}{5} + \frac{1}{10} + \frac{1}{30} = \frac{6+3+1}{30} = \frac{10}{30}$$

$$R_p = 3 \text{ ohm.}$$

Ex.28 Resistors $R_1 = 10$ ohms, $R_2 = 40$ ohms, $R_3 = 30$ ohms, $R_4 = 20$ ohms, $R_5 = 60$ ohms and a 12 volt battery is connected as shown. Calculate:

(a) the total resistance and (b) the total current flowing in the circuit.

Sol. The situation is shown in (figure).

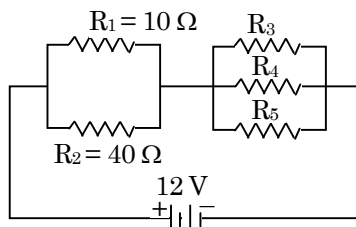

For R_1 and R_2 in parallel

$$\frac{1}{R_{p_1}} = \frac{1}{R_1} + \frac{1}{R_2} = \frac{1}{10} + \frac{1}{40} = \frac{4+1}{40} = \frac{5}{40} = \frac{1}{8}$$

or $R_{P_1} = 8 \text{ ohm}$

For R_3, R_4 and R_5 is parallel

$$\begin{aligned}\frac{1}{R_{P_2}} &= \frac{1}{R_3} + \frac{1}{R_4} + \frac{1}{R_5} = \frac{1}{30} + \frac{1}{20} + \frac{1}{60} \\ &= \frac{2+3+1}{60} = \frac{6}{60} = \frac{1}{10}\end{aligned}$$

or $R_{P_2} = 10 \text{ ohm}$.

(a) For R_{P_1} and R_{P_2} in series.

Total resistance, $R = R_{P_1} + R_{P_2}$

Putting values, we get, $R = 8 + 10 = 18 \Omega$

Total resistance, $R = 18 \text{ ohms}$

(b) From relation, (Ohm's law) $R = \frac{V}{I}$

We have, $I = \frac{V}{R}$

Putting values, we get, $I = \frac{12}{18} = \frac{2}{3} = 0.67 \text{ A}$

Total current, $I = 0.67 \text{ A}$

COMPETITIVE LEVEL

◆ Wheatstone Bridge

Wheatstone bridge is an arrangement of four resistors in the shape of a quadrilateral which can be used to measure unknown resistance in terms of the remaining three resistances.

The arrangement of Wheatstone bridge is shown in figure below. Out of four resistors, two resistances R_1, R_2 and R_3, R_4 are connected in series and are joined in parallel across two points a and c. A battery of e.m.f. E is connected across junctions a and c and a galvanometer (G) between junction b and d. The keys K_1 and K_2 are used for the flow of current in the various branches of bridge.

- **Principle of wheatstone bridge:** When key K_1 is closed, current i from the battery is divided at junction a in two parts. A part i_1 goes through R_1 and the rest i_2 goes through R_3 . When key K_2 is closed, galvanometer shows a deflection.

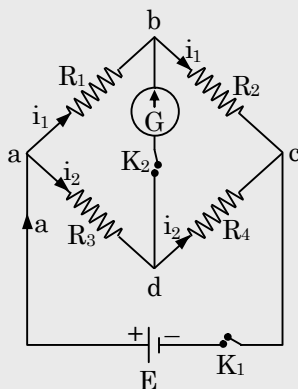

The direction of deflection depends on the value of potential difference between b and d. When the value of potential at b and d is same, then no current will flow through galvanometer. This condition is known as the condition of balanced bridge or null deflection condition. This situation can be obtained by choosing suitable values of the resistances. Thus, in null deflection state, we have:

$$V_a - V_b = V_a - V_d$$

or $i_1 R_1 = i_2 R_3$... (i)

Similarly: $V_b - V_c = V_d - V_c$

or $i_1 R_2 = i_2 R_4$... (ii)

On dividing equation (i) by (ii), we get

$$\frac{i_1 R_1}{i_1 R_2} = \frac{i_2 R_3}{i_2 R_4} \text{ or } \frac{R_1}{R_2} = \frac{R_3}{R_4} \quad \dots \text{(iii)}$$

Equation (iii) states the condition of balanced bridge. Thus, in null deflection condition the ratio of resistances of adjacent arms of the bridge are same.

The resistor of unknown resistance is usually connected in one of the arm of the bridge. The resistance of one of the remaining three arms is adjusted such that the galvanometer shows zero deflection. If resistance of unknown resistor is R_4 . Then

$$R_4 = (R_3) \left(\frac{R_2}{R_1} \right)$$

For better accuracy of the bridge one should choose resistances R_1, R_2, R_3 and R_4 of same order.

Ex.29 In the following figures, find the resistance A and B.

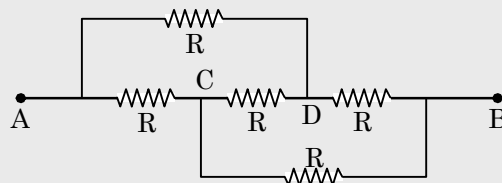
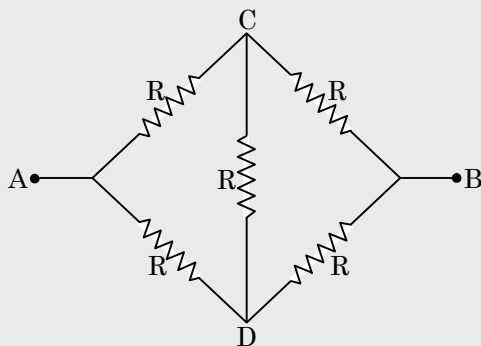

Sol.

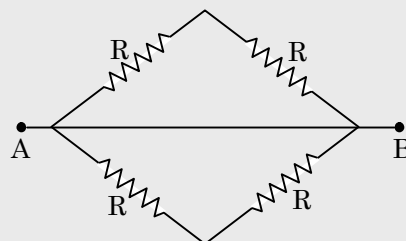

Figure (iii)

This is a balanced bridge ($P/Q = R/S$)

For this bridge, we can ignore the resistor between b and d. hence both the above fig can be put as fig (iii).

Obviously, the resistance between A and B will be R

◆ Super conductor and its applications

Prof. K. Onnes in 1911 discovered that certain metals and alloys at very low temperature lose their resistance considerably. This phenomenon is known as super-conductivity. As the temperature decreases, the resistance of the material also decreases, but when the temperature reaches a certain critical value (called critical temperature or transition temperature), the resistance of the material completely disappears i.e. it becomes zero. Then the material behaves as if it is a super-conductor and there will be flow of electrons without any resistance whatsoever. The critical temperature is different for different materials. It has been found that mercury at critical temperature 4.2 K, lead at 7.25 K and niobium at critical temperature 9.2 K become super-conductor.

• Applications of super conductors:

- (i) Super conductors are used for making very strong electromagnets.
- (ii) Super conductivity is playing an important role in material science research and high energy particle physics.
- (iii) Super conductivity is used to produce very high speed computers.
- (iv) Super conductors are used for the transmission of electric power.

More about Galvanometer, ammeter and voltmeter

◆ Galvanometer

A galvanometer is an instrument that can detect the presence of a current in a circuit. The pointer remains at zero (the centre of the scale) for zero current flowing through it. It can deflect either to the left or to the right of the zero mark depending on the direction of current.

Galvanometers are of two types:

- (i) soving coil galvanometer
- (ii) Moving magnet galvanometer

It is used to make ammeter and voltmeter as follows is:

◆ Ammeter

Ammeter is an electrical instrument which measures the strength of current in 'ampere' in a circuit which is always connected in series in circuit so that total current (to be measured) may pass through it. The resistance of an ideal ammeter is zero (practically it should be minimum).



◆ Voltmeter

It is an electrical instrument which measures the potential difference in 'volt' between two points of electric circuit. The only difference between ammeter and voltmeter is that ammeter has its negligible (approximately zero) resistance so that it may measure current of circuit passing through it more accurately giving the deflection accordingly, while the voltmeter passes negligible current through itself so that potential difference developed due to maximum current passing through circuit may be measured.

Voltmeter has very high resistance and the resistance of an ideal voltmeter is infinite.

A voltmeter is always connected in parallel.

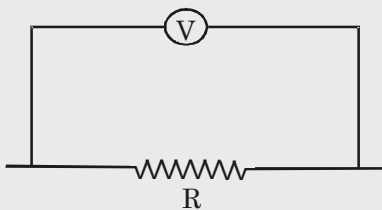

Heating Effect of Electric Current

When the ends of a conductor are connected to a battery, then free electrons move with drift velocity and electric current flows through the wire. These electrons collide continuously with the positive ions of the wire and thus the energy taken from the battery is dissipated. To maintain the electric current in the wire, energy is taken continuously from the battery. This energy is transferred to the ions of the wire by the electrons. This increases the thermal motion of the ions, as a result the temperature of the wire rises. The effect of electric current due to which heat is produced in a wire when current is passed through it is called heating effect of current or Joule's heating. In 1841 Joule found that when current is passed through a conductor the heat produced across it is:

- (i) Directly proportional to the square of the current through the conductor i.e. $H \propto I^2$
- (ii) Directly proportional to the resistance of the conductor i.e. $H \propto R$
- (iii) Directly proportional to the time for which the current is passed i.e. $H \propto t$

Combining the above three equations we have,

$$H \propto I^2 R t$$

$$\text{or } H = \frac{I^2 R t}{J} \text{ (in calorie)}$$

Where J is called Joule's mechanical equivalent of heat and has a value of $J = 4.18 \text{ J cal}^{-1}$. The above equation is called Joule's law of heating.

In some cases, heating is desirable, while in many cases, such as electric motors, generators or transformers, it is highly undesirable. Some of the devices in which heating effect of an electric current is desirable, are incandescent lamps, toasters, electric irons and stoves. The tungsten filament of an incandescent lamp operates at a temperature of 2700°C . Here, we see electrical energy being converted into both heat and light energy.

◆ Electric Energy

The fact that conductors offer resistance to the flow of current, means that work must be continuously done to maintain the current. The role of resistance in electrical circuits is analogous to that of friction in mechanics. The amount of work done by current I , flowing through a wire of resistance R during the time t is calculated by -

$$W = QV$$

but as $Q = I \times t$

Therefore, the amount of work done, W is

$$W = V \times I \times t$$

By substituting the expression for V from Ohm's law,

$$V = IR$$

we finally get $W = I^2 R t$

This shows that the electrical energy dissipated or consumed depends on the product of the square of the current I , flowing through the resistance R and the time t .

Ex.30 Why does the cord of an electric heater not glow while the heating element does, when connected to the mains?

Sol. The wires of the connecting cord of electric heater are made of Cu, negligible heat is produced in it, due to its extremely low resistance. The heating element of an electric heater is made up of nichrome wire. It glows because large amount of heat is produced due to its high resistance.

Ex.31 Compute the heat generated while transferring 96000 coulomb of charge in one hour through a potential difference of 50 V.

Sol. The amount of heat (H) produced is given by the Joule's law of heating as $H = VIt$ where, Voltage, $V = 50$ V

Time, $t = 1 \text{ h} = 1 \times 60 \times 60 \text{ s} = 3600 \text{ s}$

Amount of current, $I = q/t = 96000 / 3600 = (80/3) \text{ A}$

$$H = 50 \times \frac{80}{3} \times 60 \times 60 = 4.8 \times 10^6 \text{ J}$$

Therefore, the heat generated is $4.8 \times 10^6 \text{ J}$.

Ex.32 An electric iron of resistance 20Ω takes a current of 5 A. Calculate the heat developed in 30 s.

Sol. The amount of heat (H) produced is given by the Joule's law of heating as $H = VIt$ where, Current, $I = 5 \text{ A}$

Time, $t = 30 \text{ s}$

Voltage, $V = \text{Current} \times \text{Resistance} = 5 \times 20 = 100 \text{ V}$

$$H = 100 \times 5 \times 30 = 1.5 \times 10^4 \text{ J}$$

Therefore, the amount of heat developed in the electric iron is $1.5 \times 10^4 \text{ J}$.

- Commercial unit of electrical energy (Kilowatt - hour): The S.I. unit of electrical energy is joule and we know that for commercial purposes we use a bigger unit of electrical energy which is called "kilowatt - hour". One kilowatt - hour is the amount of electrical energy consumed when an electrical appliance having a power rating of 1 kilowatt and is used for 1 hour.

- Relation between kilowatt hour and Joule: Kilowatt-hour is the energy supplied by a rate of working of 1000 watts for 1 hour.

$$1 \text{ kilowatt-hour} = 3600000 \text{ Joules}$$

$$1 \text{ kWh} = 3.6 \times 10^6 \text{ J}$$

◆ Electric Power

The rate at which electric energy is dissipated or consumed, is termed as electric power. The power P is given by,

$$P = W/t = I^2 R$$

The unit of electric power is watt, which is the power consumed when 1A of current flows at a potential difference of 1 V.

- **Unit of power:** The S.I. unit of electric power is 'watt' which is denoted by the letter W . The power of 1 watt is a rate of working of 1 joule per second.

A bigger unit of electric power is kilowatt.

$$1 \text{ kilowatt (kW)} = 1000 \text{ watt.}$$

Power of an agent is also expressed in horse power (hp).

$$1 \text{ hp} = 746 \text{ watt}$$

- **Formula for calculating electric power:**

$$\text{We know, Power, } P = \frac{\text{Work}}{\text{Time}}$$

and Work, $W = V \times I \times t$

$$P = \frac{V \times I \times t}{t} \Rightarrow P = V \times I$$

Power P in terms of I and R :

Now from Ohm's law we have, $\frac{V}{I} = R$

$$V = I \times R$$

$$P = I \times R \times I$$

$$P = I^2 \times R$$

Power P in terms of V and R:

We know, $P = V \times I$

From Ohm's law $I = \frac{V}{R}$

$$P = V \times \frac{V}{R} \Rightarrow P = \frac{V^2}{R}$$

Ex.33 What determines the rate at which energy is delivered by a current?

Sol. The rate of consumption of electric energy in an electric appliance is called electric power. Hence, the rate at which energy is delivered by a current is the power of the appliance.

Ex.34 An electric motor takes 5 A from a 220 V line. Determine the power of the motor and the energy consumed in 2 h.

Sol. Power of motor = $VI = 220 \times 5 = 1100$ W

Energy consumed in 2 h = Power \times time = $1100 \text{ W} \times 2 \times 60\text{s} \times 60\text{s} = 1100 \text{ W} \times 7200\text{s} = 7.92 \times 10^6 \text{J}$

- Calculation of Electric bill:

Energy consumed by electric appliances is given by the formula.

$$\text{Electric energy (in kWh)} = \frac{\text{no. of appliances} \times \text{Power of appliances (in watt)} \times \text{Time (in hour)}}{1000}$$

◆ Power-Voltage Rating of Electrical Appliances

Every electrical appliance like an electric bulb, radio or fan has a label or engraved plate on it which tells us the voltage (to be applied) and the electrical power consumed by it. For example, if we look at a particular bulb in our home, it may have the figures 220 V, 100 W written on it. Now, 220 V means that this bulb is to be used on a voltage of 220 volts and 100 W which means, it has a power consumption of 100 watts or 100 joules per second, when supplied a voltage of 220 volt.

◆ Applications of Heating Effect of Current

Domestic electrical appliances such as electric bulb, electric iron, geyser, room heater etc work on heating effect of current and are rated in terms of voltage and wattage. The coils of these devices are made of a material of a very high resistance, (for instance, nichrome or tungsten) such that when a current passes through the coil, heat is generated. Generally the potential difference applied to the electrical appliance is the same as that of the mains i.e. 220 - 230 V in India and 110 V in U.S.A., Canada etc.

Note: The most popular heating element nichrome is an alloy of 60% nickel, 25% iron and 15% chromium. It has low resistance and high melting point.

◆ Electric Fuse

An electric fuse is an easily fusible wire of short length put into an electrical circuit for protection purposes. It is arranged to melt ("blow") at a definite current.

It is an alloy of lead and tin (37% lead + 63% tin). It has a high resistivity and low melting point. As soon as the safe limit of current exceeds, the fuse "blows" and the electric circuit is cut off.

Ex.35 15 bulbs of 60W each, run for 6 hours daily and a refrigerator of 300 W runs for 5 hours daily. Work out per day bill at 3 rupees per unit.

Sol. Total wattage of 15 bulbs = $15 \times 60 \text{ W} = 900 \text{ W}$

Electrical energy consumed by bulbs per day = $P \times t = 900 \times 6 = 5400 \text{ Wh}$

And electrical energy consumed by refrigerator per day = $300 \times 5 = 1500 \text{ Wh}$

Total electrical energy consumed per day = $(5400 + 1500) \text{ Wh} = 6900 \text{ Wh}$

Electrical energy consumed per day = $\frac{6900}{1000} \text{ kWh} = 6.9 \text{ kWh}$

Here, per day bill = $\text{Rs. } 6.9 \times 3 = \text{Rs. } 20.70$

EXERCISE-1

➤ Very Short Answer Type Questions

- Q.1** What is represented by joule/coulomb?
- Q.2** What is the function of electric switch in electric circuit?
- Q.3** A wire of resistivity 10 ohm-meter is stretched to double its length. What is its new resistivity?
- Q.4** What is the SI unit of Power?
- Q.5** A charge of 2C moves between two plates, maintained at a p.d of 1V. What is the energy acquired by the charge?

➤ Short Answer Type Questions – Type I

- Q.6** Draw a schematic diagram of a typical electric circuit comprising a cell, an electric bulb, an ammeter and a plug key.
- Q.7** What makes the electric charge to flow in a conducting metallic wire?
- Q.8** Two wires of same material and same length have radii r_1 and r_2 , compare their resistances.
- Q.9** A wire of length L and resistance R is stretched so that its length is doubled. How will its
 (a) Resistance change
 (b) Resistivity change?
- Q.10** Calculate the electrical energy consumed by a 1200W toaster in 20 minutes.

➤ Short Answer Type Questions – Type II

- Q.11** Write any three properties of charges.
- Q.12** If '2q' coulombs of charge travel through a conductor of length ' l ' m with a velocity of ' v ' m/s, what is the current flowing through the conductor?

- Q.13** A TV set shoots out a beam of electrons. The beam current is $10\mu\text{A}$.
 (a) How many electrons strike the TV screen in each second?
 (b) How much charge strikes the screen in a minute?

- Q.14** (a) Why do copper or aluminium wires generally used for electrical transmission and distribution purposes?
 (b) Two wires, one of copper and other of manganin, have equal lengths and equal resistances. Which wire is thicker? Given that resistivity of copper is lower than that of manganin.

- Q.15** Two conductors X and Y of circular cross-section have radii in the ratio of 1: 2, length in the ratio 1: 3 and resistivities in the ratio of 3: 1, then in which ratio their resistances are?

- Q.16** Given n resistors each of resistance r . How will you combine them to get the
 (i) Maximum and
 (ii) Minimum effective resistance? What is the ratio of the maximum to minimum resistance?

- Q.17** Three resistances are connected as shown in diagram. Through the resistance 5 ohms, a current of 1 ampere is flowing:

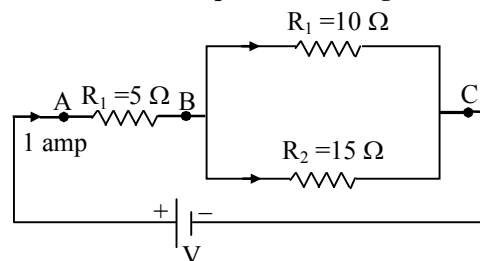

- (i) What is the current through the other two resistors?
 (ii) What is the potential difference (p.d.) across AB and across AC?
 (iii) What is the total resistance?

- Q.18** Explain heating effect of current in brief and deduce the formula used..

- Q.19** A household uses the following electrical appliances:
- (i) Refrigerator of rating 400 W for ten hours every day.
 - (ii) Two electric fans of rating 80 W each for twelve hours every day.
 - (iii) Six electric tubes of rating 18 W each for 6 hours every day.
- Calculate the electricity bill of the household for the month of June if the cost per unit of electric energy is Rs. 3.00.
- Q.20** Two lamps, one rated 60 W at 220 V and the other 40 W at 220 V, are connected in parallel to the electric supply at 220 V.
- (a) Draw a circuit diagram to show the connections.
 - (b) Calculate the current drawn from the electric supply.
 - (c) Calculate the total energy consumed by the two lamps together when they operate for one hour.

➤ Long Answer Type Questions

- Q.21** Write any five differences between static and current electricity?
- Q.22** What is potential difference? Define its SI unit. Which instrument is used to measure it and how it is used?
- Q.23** Write activities that can be performed to show that in a series combination of resistors the current is same in every part of the circuit or same current passes through each resistor.
- Q.24** Derive the equation for resultant resistance of resistors in series.
- Q.25** Derive the equation for resultant resistance in parallel.

EXERCISE-2

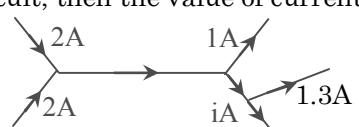
- Q.1** When a body is negatively charged by friction, it means
 (A) the body has acquired excess of electrons
 (B) the body has acquired excess of protons
 (C) the body has lost some electrons
 (D) the body has lost some neutrons
- Q.2** When the distance between the charged particles is halved, the force between them becomes
 (A) One-fourth (B) Half
 (C) Double (D) Four times
- Q.3** How many electrons in 1 s constitute a current of 1 A?
 (A) 6.25×10^{18} (B) 6.25×10^{12}
 (C) 6.25×10^{11} (D) 6.25
- Q.4** If a charged body attracts another body, the charge on the other body
 (A) must be negative
 (B) must be positive
 (C) must be zero
 (D) may be negative or positive or zero
- Q.5** A suitable unit for expressing the strength of electric field is
 (A) V/C (B) C/m (C) N/C (D) C/N
- Q.6** A particle of mass m and charge q is placed at rest in a uniform electric field E and then released. The kinetic energy attained by the particle after moving a distance y is
 (A) qEy^2 (B) qE^2y
 (C) qEy (D) q^2Ey
- Q.7** The number of electrons to be put on a spherical conductor of radius $0.1m$ to produce an electric field of $0.036N/C$ just above its surface is
 (A) 2.7×10^5 (B) 2.6×10^5
 (C) 2.5×10^5 (D) 2.4×10^5
- Q.8** An electric bulb of 40 W is connected to a source of 220 V, the current drawn by the bulb will be
 (A) 1.8 A (B) 18 A
 (C) 0.18 A (D) 180 A
- Q.9** What is not true for electric charge :
 (A) Electric charge is scalar quantity
 (B) Charge on a body may be +ve or -ve
 (C) S.I. unit of charge is coulomb
 (D) One coulomb is charge of one electron
- Q.10** A metallic sphere has a charge of $10\mu C$. A unit negative charge is brought from A to B both 100 cm away from the sphere but A being east of it while B being on west. The net work done is
 (A) Zero (B) 2/10 joule
 (C) -2/10 joule (D) -1/10 joule
- Q.11** 1 Coulomb is equal to
 (A) 1 amp \times 1 sec (B) 1 amp / 1 sec
 (C) 1 joule \times 1 amp (D) 1 joule / 1 sec
- Q.12** One ampere equals
 (A) $10^6 \mu A$ (B) $10^{-6} \mu A$
 (C) $10^{-3} \mu A$ (D) $10 \mu A$
- Q.13** If I is the current through a wire and 'e' is the charge of electron then the number of electrons in t seconds will be given by
 (A) $\frac{Ie}{t}$ (B) e/It
 (C) It/e (D) Ite
- Q.14** Figure shows current in a part of electrical circuit, then the value of current is-
- 
- (A) 1.7 A (B) 3.7 A
 (C) 13 A (D) 1.0 A
- Q.15** The unit of resistivity is
 (A) ohm (B) ohm meter
 (C) ohm meter⁻¹ (D) mho meter⁻¹
- Q.16** If a wire of resistance 1Ω is stretched to double its length, then the resistance will become
 (A) $\frac{1}{2} \Omega$ (B) 2Ω (C) $\frac{1}{4} \Omega$ (D) 4Ω

- Q.17** In the given circuit, the effective resistance between points A and C will be

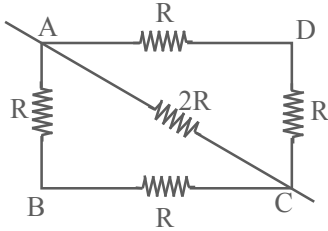

- (A) $\frac{3}{2}R$ (B) $6R$ (C) $\frac{2}{3}R$ (D) $3R$

- Q.18** A wire of resistance R is cut into n equal parts. These parts are then connected in parallel. The equivalent resistance of combination will be
(A) nR (B) R/n (C) n/R (D) R/n^2

- Q.19** A piece of wire of resistance 4Ω is bent through 180° at its mid point and the two halves are twisted together, then resistance is
(A) 1Ω (B) 2Ω
(C) 5Ω (D) 8Ω

- Q.20.** Calculate the equivalent resistance between P & Q of the network. Show in the figure given.

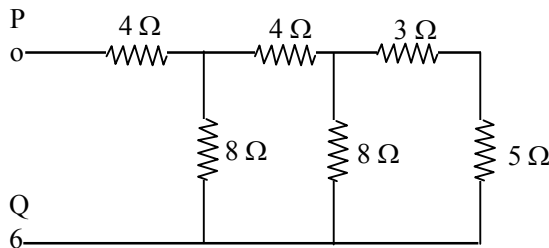

- (A) 8Ω (B) 4Ω
(C) 6Ω (D) 9Ω

- Q.21** Which of the following effects of current does not depend on direction of current?
(A) Lighting and chemical effect
(B) Heating and lighting effect
(C) Heating and magnetic effect
(D) Magnetic and chemical effect

- Q.22** Two heater wires of equal length are first connected in series and then in parallel with a battery. The ratio of heat produced in the two cases is
(A) 2: 1 (B) 1: 2 (C) 4: 1 (D) 1: 4

- Q.23** The resistance of a conductor is reduced to half its initial value. In doing so the heating effects in the conductor will become
(A) Half (B) One-fourth
(C) Four times (D) Double

- Q.24** Laws of heating are given by
(A) Faraday (B) Joule
(C) Ohm (D) Maxwell

- Q.25** Which of the following statement is false?
(A) Heat produced in a conductor is proportional to its resistance
(B) Heat produced in a conductor is proportional to the square of the current
(C) Heat produced in a conductor is proportional to charge
(D) Heat produced in a conductor is proportional to the time for which current is passed

- Q.26** The filament of an electric bulb is made of tungsten because
(A) Its resistance is negligible
(B) It is cheaper
(C) Its melting point is high
(D) Its filament is easily made

- Q.27** Electric power is transmitted over long distance through conducting wires at very high voltage because
(A) The power losses are reduced to minimum
(B) Signal of high voltage travel faster
(C) High voltage can be stepped down to desired levels easily
(D) None of these

- Q.28** Rate of heat generated by electric current in a resistive circuit is expressed in
(A) IR (B) IR^2 (C) I^2R (D) \sqrt{IR}

- Q.29** Commercial unit of electrical energy is
(A) Calorie
(B) Joule
(C) Kilowatt hour
(D) All of these

- Q.30** Power rating of an electric appliance indicates
(A) The rate of consumption of electrical energy
(B) Amount of heat evolved
(C) Brightness of the light
(D) Quality of the appliance

EXERCISE-3

(Previous Year Questions - NTSE & NSO)

- Q.1** In the given circuit diagram, the value of resistance X in ohm when the bridge is balanced (galvanometer current is zero) will be

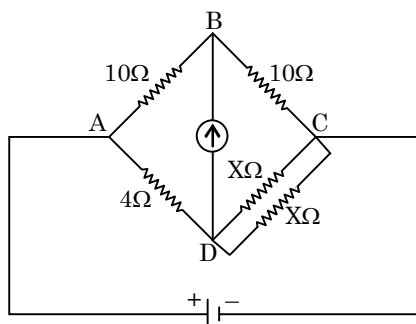

- (A) 4 (B) 8
(C) 10 (D) 12

- Q.2** In the following figure, the equivalent resistance between the points A and B in ohm will be

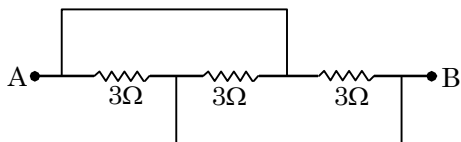

- (A) 1 (B) 2 (C) 3 (D) 9

- Q.3** In the circuit shown in figure, the current flowing through $5\ \Omega$ resistance is

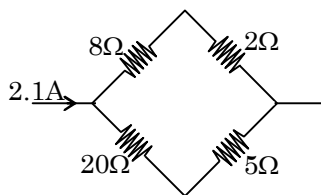

- (A) 0.5A (B) 0.6A
(C) 0.9 A (D) 1.5 A

- Q.4** The material of heating element in an electric press has

- (A) high melting point and high specific resistance
(B) high melting point and low specific resistance
(C) low melting point and high specific resistance
(D) low melting point and high specific resistance

- Q.5** A uniform wire when connected directly across a 220V line produces heat H per second. If the wire is divided into n -parts and all parts are connected in parallel across a 220 V line, the heat produced per second will be

- (A) H/n (B) n^2H
(C) H/n^2 (D) nH

- Q.6** One Volt is equal to

- (A) 1 Joule
(B) 1 Newton/Coulomb
(C) 1 Joule/Coulomb
(D) 1 Coulomb/Newton

- Q.7** On a bulb it is written as 220 Volt and 60 watt. Find out the resistance of the bulb and the value of the current flowing through it

- (A) 806.66 ohm / 0.27 ampere
(B) 500 ohm / 2 ampere
(C) 200 ohm / 4 ampere
(D) 100 ohm / 1 ampere

- Q.8** A comb run through one's dry hair attracts small bits of paper. This is due to

- (A) comb is a good conductor
(B) paper is a good conductor
(C) The atoms in the paper gets polarized by the charged comb
(D) the comb possesses magnetic properties

- Q.9** The value of current I and voltage V in the given circuit will be

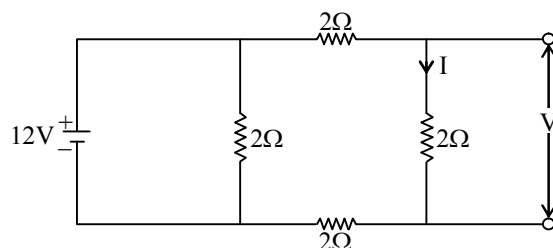

- (A) 2A, 4V (B) 4A, 2V
(C) 1A, 2V (D) 2A, 1V

Q.10 When 1 J of work is done to move a charge of 1 C from one point to another point then the potential difference between two points in a given circuit will be

- (A) 1 V (B) 4V
(C) 8 V (D) zero.

Q.11 The value of equivalent resistance between the point A and B in the given circuit will be

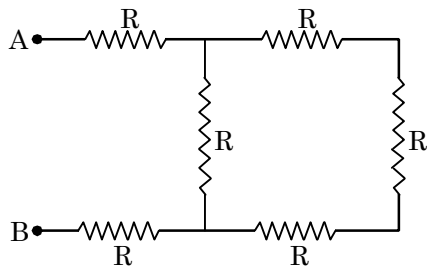

- (A) 6 R (B) $\frac{4R}{11}$
(C) $\frac{11R}{4}$ (D) $\frac{R}{6}$

Q.12 Find the reading of the ammeter in the circuit given below

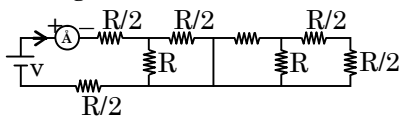

- (A) $\frac{V}{2R}$ (B) $\frac{3V}{4R}$
(C) $\frac{2V}{7R}$ (D) $\frac{11V}{R}$

Q.13 A certain household has consumed 200 units of energy during a month. Its value in joules will be

- (A) 3.6×10^{10} (B) 7.2×10^{10}
(C) 3.6×10^8 (D) 7.2×10^8

Q.14 In a neon gas discharge tube, every second 4.8×10^{18} Ne^+ ions move towards the right through a cross-section of the tube, while 'n' electrons move to the left in the same time. If the current in the tube is 1.12 amperes towards the right, n is equal to (given $e = 1.6 \times 10^{-19}$ coulomb)

- (A) 1.8×10^{18} (B) 2.2×10^{18}
(C) 2.4×10^{19} (D) 2.8×10^{19}

Q.15 Four 20Ω resistors are connected in series and the combination is connected to a 20 V emf device. The potential difference across any one of the resistors is -

- (A) 5V
(B) 2V
(C) 4V
(D) 20V

Q.16 Of the following, the copper conductor that has the least resistance is

- (A) thin, long and hot
(B) thick, short and cool
(C) thick long and hot
(D) thin, short and cool

Q.17 Three 6Ω resistors are connected in parallel and the combination is connected to a 15 V battery. The current through any one of the resistors will be

- (A) 2.5 A (B) 2.0 A
(C) 5 A (D) 10 A

Q.18 The electrical resistivity of a conducting wire is K. If its length and area of cross section are doubled then the new resistivity of the wire will be

- (A) K (B) 2K
(C) K/2 (D) K/4

Q.19 What is the equivalent resistance of the given circuit between points A and B?

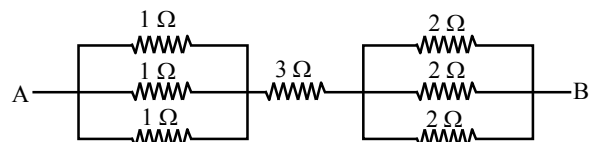

- (A) 10 Ω (B) 4 Ω
(C) $\frac{14}{3} \Omega$ (D) $\frac{17}{6} \Omega$

Q.20 4 bulbs rated 100 W each, operate for 6 hours per day. What is the cost of the energy consumed in 30 days at the rate of Rs. 5 /kWh?

- (A) Rs. 360 (B) Rs. 90
(C) Rs. 120 (D) Rs. 400

Q.21 If the current through a resistor is increased by 50%, the increase in power dissipated will be (assume the temperature remains constant)

- (A) 225% (B) 200%
(C) 250% (D) 125%

Q.22 Conductivity of superconductors is:

- (A) Infinite (B) Very large
(C) Very Small (D) Zero

Q.23 1 KWh equal to:

- (A) 3.6×10^4 J (B) 3.6×10^5 J
(C) 3.6×10^6 J (D) 3.6×10^7 J

Q.24 In a Helium gas discharge tube, every second 40×10^{18} He⁺ (ions) move towards the right through a cross –section of the tube, while n electrons move to the left in the same time. If the current in the tube is 8A to towards right then n = ?

- (A) 3×10^{18} (B) 3×10^{19}
(C) 3×10^{20} (D) 3×10^{21}

ANSWER KEY

EXERCISE - 1

3. 40ω
5. 2 J
8. $\frac{R_1}{R_2} = \left(\frac{r_2}{r_1}\right)^2$
10. $1.44 \times 10^6 \text{ J}$
12. $2qv/\ell$
13. (a) 6.25×10^{13} (b) $6 \times 10^{-4} \text{ C}$
15. 4:1
16. (i) series (ii) parallel (iii) n^2
17. (i) $I_1 = 0.6 \text{ A}$, $I_2 = 0.4 \text{ A}$. (ii) P.D. across AB = 5 V. P.D. across AC = 11 V
(iii) Total circuit resistance = 11 Ω .
19. Rs 591 (Approx.)
20. 0.45 A, $3.6 \times 10^5 \text{ J}$
26. Both are correct because $\Delta V/\Delta I = \text{resistance}(R)$ and $\Delta I/\Delta V = 1/R$
Series combination gives high resistance and parallel combination gives low resistance
27. Correct reading of ammeter = 130 Ma
Correct reading of voltmeter = 1.5 V

EXERCISE - 2

Ques.	1	2	3	4	5	6	7	8	9	10	11	12	13	14	15
Ans.	A	D	A	D	C	C	C	C	D	A	A	A	C	A	B
Vod Code	PXELE1														
Ques.	16	17	18	19	20	21	22	23	24	25	26	27	28	29	30

EXERCISE - 3

Ques.	1	2	3	4	5	6	7	8	9	10	11	12	13	14	15
Ans.	B	A	B	B	B	C	A	C	A	A	C	B	D	B	A
Ques.	16	17	18	19	20	21	22	23	24						
Ans.	B	A	A	B	A	D	A	C	C						

SOLUTIONS

EXERCISE-1

➤ Very Short Answer Type Questions

Sol.1 As all know $V = \frac{W}{Q}$
 v = potential difference
 W = work
 Q = charge
 W = joules Q = coulomb
 so, quantity will be potential

Sol.2 It is used to interrupt the flow of Electric current.

Sol.3 resistivity is the property of material which is independent of dimension of material so there is no change in resistivity $\rho=10 \Omega\text{-m}$

Sol.4 Watt is SI unit of Power .

Sol.5 using Relation $V = \frac{W}{Q} \Rightarrow 1 = \frac{W}{2}$
 $\Rightarrow W = 2$ joules in form of energy

➤ Short Answer Type Questions – Type I

Sol.6

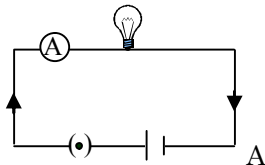

Sol.7 When potential difference is applied, it creates electric field inside the wire which applies force on free electrons.

Sol.8 As all know $R = \frac{\rho \ell}{A}$
 $\frac{R_1}{R_2} = \frac{\rho \ell}{A_1} \times \frac{A_2}{\rho \ell}$
 ρ, ℓ are same for both wires.
 $\frac{R_1}{R_2} = \frac{r_2^2}{r_1^2}$

Sol.9 (a)

$$R = \frac{\rho \ell}{A} \quad l = \text{doubled} \Rightarrow \text{Area becomes half}$$

$$R^1 = \frac{\rho(2\ell)}{A/2}$$

$$R^1 = 2R$$

(b) resistivity is the property of material which is independent of dimension of material

so there is no change in resistivity

Sol.10 $p = \frac{E}{t} \Rightarrow E = p \times t = 1200 \times 20 \times 60$

$$E = 1440 \text{ KJ}$$

➤ Short Answer Type Questions – Type II

Sol.11 (i) Likes charges repel and unlike charges attract

(ii) Quantization of charges

(iii) Charge always associated with mass.

Sol.12 $I = \frac{Q}{t} \quad t = \frac{d}{v} = \frac{\ell}{v}$

$$I = \frac{2qv}{\ell}$$

Sol.13 (a) $I = \frac{Q}{t}$

$$Q = I \cdot t$$

$$Q = 10 \times 10^{-6} \times 1$$

$Q = 10 \times 10^{-6} \text{ C} \Rightarrow$ this amount of charge strikes the screen in each second

$$1\text{C} = \frac{1}{1.6 \times 10^{-19}} e$$

$$10 \times 10^{-6} = \frac{1}{1.6 \times 10^{-19}} \times 10 \times 10^{-6} e$$

$$= 6.25 \times 10^{13} e$$

(b) $Q = I \cdot t = 10 \times 10^{-6} \times 1 \times 60$

$$Q = 600 \times 10^{-6} \text{ C}$$

Sol.14 (a) They are good conductors of electricity and cheap.

(b) $R_{\text{copper}} = R_{\text{magnain}}$

$$\frac{\rho_c \ell_c}{A_c} = \frac{\rho_m \ell_m}{A_m} \quad \ell_c = \ell_m$$

$$\frac{A_m}{A_c} = \frac{\rho_m}{\rho_c}$$

$$\rho_c = 1.72 \times 10^{-8} \Omega \text{ m}$$

$$\rho_m = 4.55 \times 10^{-5} \Omega \text{ m}$$

$$\rho_m > \rho_c$$

$A_m > A_c$ manganin is thicker.

Sol.15

$$\frac{R_1}{R_2} = \frac{\rho_1 \ell_1 / A_1}{\rho_2 \ell_2 / A_2} = \frac{\rho_1}{\rho_2} \times \frac{\ell_1}{\ell_2} \times \frac{A_2}{A_1}$$

$$\frac{R_1}{R_2} = \frac{4}{1}$$

Sol.16 (a) maximum resistance will be in series combination

$$R_{\text{eq}} = R_1 + R_2 + R_3 \dots n$$

$$R_{\text{eq}} = nr$$

(b) when connected in parallel combination the equivalent resistance will be less than the smallest resistance in parallel combination

$$\frac{1}{R_{\text{eq}}} = \frac{1}{R_1} + \frac{1}{R_2} + \frac{1}{R_3} \dots n =$$

$$\frac{1}{R} + \frac{1}{R} + \dots$$

$$R_{\text{eq}} = \frac{R}{n}$$

$$\frac{R_{\text{man}}}{R_{\text{min}}} = \frac{nr}{r/n} = \frac{n^2}{1}$$

Sol.17

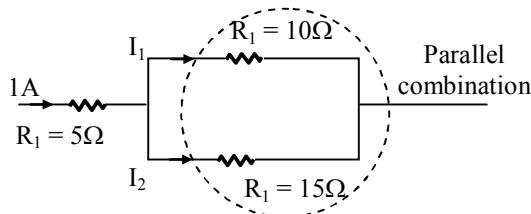

$$R_{\text{eq}} = \frac{R_1 R_2}{R_1 + R_2} = \frac{15 \times 10}{15 + 10} = \frac{150}{25}$$

$$R_{\text{eq}} = 6\Omega$$

(a) Equivalent circuit

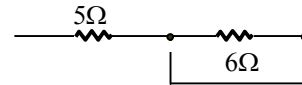

$$\text{voltage} = IR = 1 \times 6 = 6V$$

voltage across R_1 is 6v

$$I_1 = \frac{V}{R_1} = \frac{6}{10} = 0.6A$$

$$I_2 = 0.4A$$

$$\text{(ii) } V_{\text{AB}} = IR = 1 \times 5 = 5V$$

$$V_{\text{AC}} = I R_{\text{eq}} = 1 \times 11 = 11V$$

$$\text{(iii) } R_{\text{eq}} = 5 + 6 = 11\Omega$$

Sol.18 When an electric current is passed through a conductor, the conductor becomes hot due to collision, electrical energy through conductor is converted to heat energy. This effect of electric current is called heating effect of current.

$$H \propto I^2 R t$$

$$H = \frac{I^2 R t}{J}$$

J = Joule's Heat mechanical equivalent

$$J = 4.18 \text{ J cal}^{-1}$$

Derivation

$$W = QV$$

$$Q = I \times t$$

$$W = VI t$$

according to ohm's law $V = IR$

$$W = IR \cdot I \cdot t$$

$$W = I^2 R t$$

Sol.19 (i) Energy consumption by Refrigerator

$$E = p \times t$$

$$E = 400 \times 10$$

$$E = 4000 \text{ wh (per day)}$$

(ii) By two fans

$$E = 2 \times (80 \times 12)$$

$$E = 1920 \text{ wh (per day)}$$

(iii) By electric tubes

$$E = 6 \times (18 \times 6)$$

$$E = 648 \text{ wh}$$

$$\text{Total Energy consumption} = 4000 + 1920 + 648 = 6568 \text{ wh (per day)}$$

Total Energy consumption in month of June

$$= 6568 \times 30$$

$$= 197040 \text{ wh}$$

$$= 197.044 \text{ kwh}$$

Electricity bill = Energy unit \times Charge per unit

$$= 197.04 \times 3 = \text{Rs } 591.12$$

Sol.20 (a)

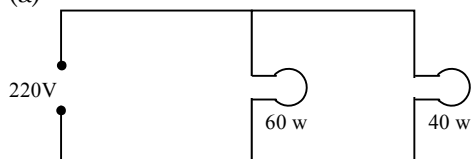

Resistance of 40 w

$$R_{40} = \frac{v^2}{p} = \frac{(220)^2}{40} = 1210\Omega$$

$$R_{60} = \frac{(220)^2}{60} = 806.675$$

(b) Current in 60 W

using formula $P = VI \Rightarrow I = \frac{P}{V} = \frac{60}{220} = 0.27A$

Current in 40 W

$$I = \frac{40}{220} = 0.18A$$

$$I_{Total} = 0.27 + 0.18 = 0.45A$$

(c) $P_{total} = P_1 + P_2$ in parallel combination

$$= 60 + 40$$

$$= 100w$$

$$\text{energy} = \text{power} \times \text{time} \quad 1 \text{ hour} = 3600 \text{ sec}$$

$$= 100 \times (1 \times 3600)$$

$$= 100 \times 3600$$

$$= 36 \times 10^4 \text{ Joules}$$

➤ Long Answer Type Questions

Sol.21

	Static	Current Electricity
(i)	The electricity which is build upon the surface of the substance is known as static electricity	The current electricity is because of flow of electrons
(ii)	It induces because of the movement of negative charges from one object to another.	It is because of movement of free electrons
(iii)	It develops both in the conductor and insulator	develops only in conductor
(iv)	Not induces the magnetic field	It induces magnetic field
(v)	Exist for short time	Exist for long lime
(vi)	Measured using Gold leaf electroscope	Analog and digital meter.

Sol.22 The work done in taking a charge from one point to the other in an electric field is called the potential difference between two point

S.I. unit = Volt

Voltmeter, it is connected in parallel combination.

Sol.23 Connect ammeters in such a way as shown below, all Ammeters shows equal values.

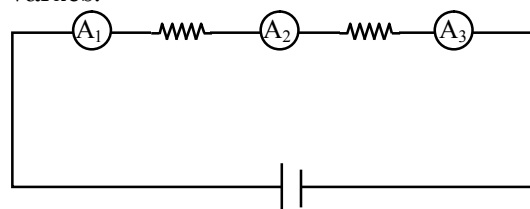

A_1, A_2, A_3 all will give some reading

Sol.24

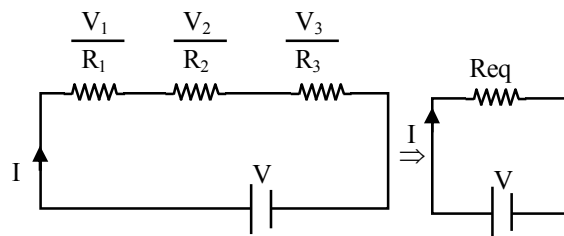

$$V_{net} = V_1 + V_2 + V_3$$

Applying ohm's law

$$V_1 = IR, \quad V_2 = IR_2, \quad V_3 = IR_3$$

$$V_{net} = I \times Req$$

$$I Req = IR_1 + IR_2 + IR_3$$

$$Req = R_1 + R_2 + R_3$$

Sol.25

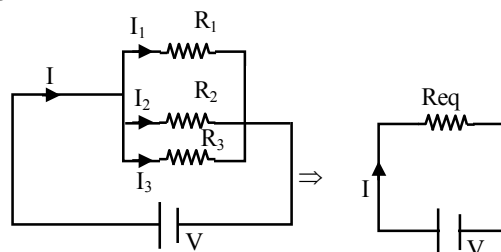

According to junction law

$$I = I_1 + I_2 + I_3$$

Applying ohm's law

$$I = V/R_{eq}, \quad I_1 = V/R_1, \quad I_2 = V/R_2, \quad I_3 = V/R_3$$

$$\frac{V}{R_{eq}} = \frac{V}{R_1} + \frac{V}{R_2} + \frac{V}{R_3}$$

$$\frac{1}{R_{eq}} = \frac{1}{R_1} + \frac{1}{R_2} + \frac{1}{R_3}$$

EXERCISE-2

Sol.1 [A]
when electron is gained by an object ,acquired negative charge on it.

Sol.2 [D]

$$F \propto \frac{1}{r^2} \text{ if } r' = \frac{r}{2}$$

$$F' = 4F$$

Sol.3 [A]
As we knew

$$I = \frac{Q}{t} \Rightarrow 1 = \frac{Q}{1}$$

$$Q = 1C$$
 1C of charge to flow in 1Ω to bare 1A

$$1e^- = 1.6 \times 10^{-19}C$$

$$1C = \frac{1}{1.6 \times 10^{-19}} e$$

$$= 6.25 \times 10^{18} e$$

Sol.4 [D]
Another body may be negative or positive or zero if it is:-
 (+), it can attract negative as well as neutral
 (-), it can attract positive as well as neutral
Note: Neutral body is attracted due to charge induced on surface due to process of induction.

Sol.5 [C]
Mathematical relation

$$E = \frac{f}{q} \quad E = \text{electric field } f = \text{force}$$

$$q = \text{charge}$$
 Unit of $E = \frac{N}{C}$

Sol.6 [C]
Force applied due to electric field $f = qE$
work done by electric field will be converted to kinetic energy.

$$W = f \cdot d$$

$$W = qE \cdot y$$

Sol.7 [C]

$$E = \frac{kQ}{r^2}$$

$$0.036 = \frac{9 \times 10^9 \times Q}{(0.1)^2}$$

$$Q = 4 \times 10^{-5} \times 10^{-9}$$

$$Q = 4 \times 10^{-14} C$$

$$1C = 6.25 \times 10^{18}$$

$$4 \times 10^{-14} C = 6.25 \times 10^{18} \times 4 \times 10^{-14} e^-$$

$$= 2.5 \times 10^5 e^-$$

Sol.8 [C]
The current drawn by the bulb will be $P=VI$
i.e $I=P/V=40/220=0.18 A$

Sol.9 [D]
Charge on $1e^- = 1.6 \times 10^{-19}C$

Sol.10 [A]
 $W = q \Delta v$
at 'A' and 'B'

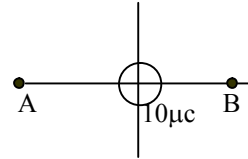

potentials are same
so $\Delta v = 0$
 $w = 0$

Sol.11 [A]

$$I = \frac{Q}{t}$$

$$Q = I \cdot t$$

$$= 1A \times 1s$$

Sol.12 [A]
 $1\mu A = 10^{-6} A$
So $1A = 10^6 \mu A$

Sol.13 [C]

$$I = \frac{Q}{t}$$
 Let there are n electron pass so total charge passed = ne

$$I = \frac{ne}{t}$$

$$n = It/e$$

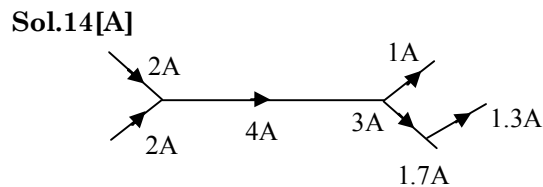

Sol.15 [B]

$$R = \frac{\rho \ell}{A}$$

$$\rho = \frac{RA}{\ell}$$

$$= \frac{\Omega \cdot \text{m}^2}{\text{m}}$$

$$\rho = \Omega \text{ m}$$

Sol.16 [D]

l = double \Rightarrow Area become half

$$R = \frac{\rho \ell}{A} \quad R' = \frac{\rho(2\ell)}{A/2} = 4R$$

$$R' = 4 \times 1$$

$$R' = 4\Omega$$

Sol.17 [C]

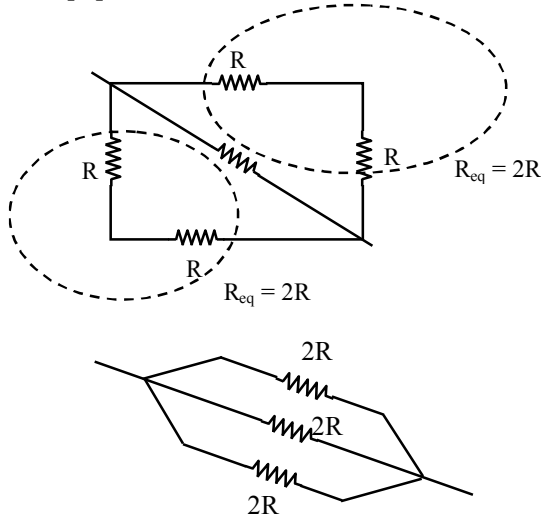

These three are in parallel combination

$$\frac{1}{R_{eq}} = \frac{1}{2R} + \frac{1}{2R} + \frac{1}{2R}$$

$$R_{eq} = \frac{2R}{3}$$

Sol.18 [D]

When Resistance is cut into 'n' equal parts

Resistance of 1 part = R/n

Parallel combination

$$\frac{1}{R_{eq}} = \frac{1}{R_1} + \frac{1}{R_2} + \frac{1}{R_3} \dots$$

$$\frac{1}{R_{eq}} = \frac{n}{R} + \frac{n}{R} \dots$$

$$R_{eq} = R/n^2$$

Sol.19 [A]

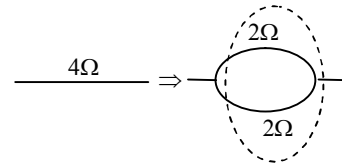

Both are in parallel $R_{eq} = 1\Omega$

Sol.20 [A]

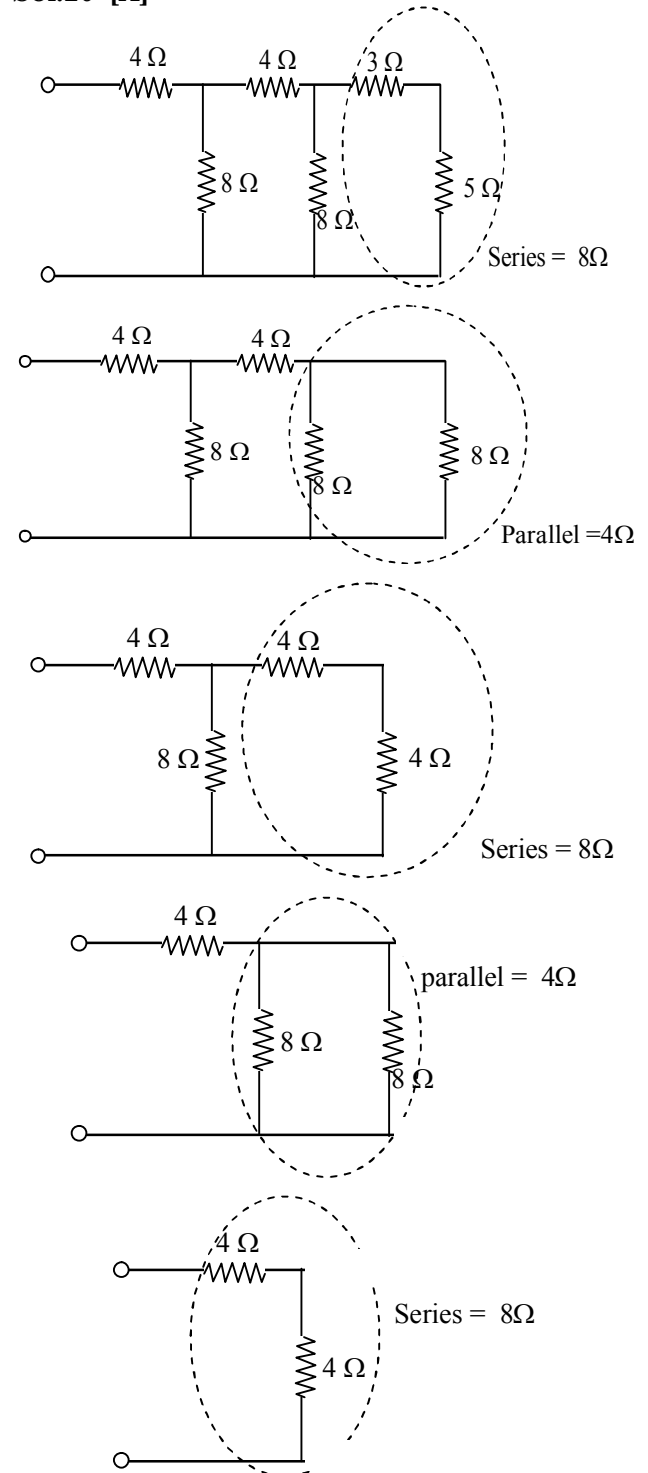

Sol.21 [B]

Heating effect is due to collision of electrons. for lightning there is no direction necessary.

Sol.22 [D]

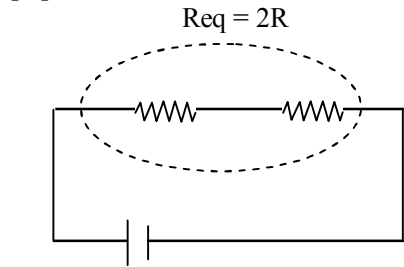

$$H_s = \frac{V^2}{R_{eq}} = \frac{V^2}{2R}$$

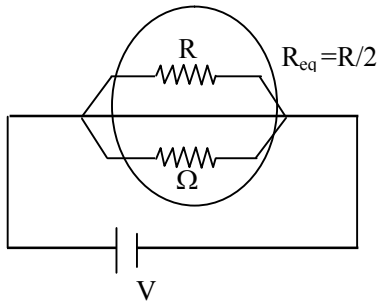

$$H_p = \frac{V^2}{R_{eq}} = \frac{V^2}{R/2} = \frac{2V^2}{R}$$

$$\text{Ratio } \frac{H_s}{H_p} = \frac{1}{4}$$

Sol.23 [D]

Since the source remains same, voltage remain same.

$$H = \frac{V^2}{R}$$

$$H^1 = \frac{V^2}{R/2} = \frac{2V^2}{R} = 2H$$

Sol.24 [B]

Joules law of heating

Sol.25 [C]

Heat produced in a conductor does not depend on charge but it depends on rate of flow of charges.

Sol.26 [C]

For filament of electric bulb, melting point should be high so that it does not melt.

Sol.27 [A]

Higher the voltage, lower the current. the lower current, the lower the power losses in the conductor.

Sol.28 [C]

Rate of heat generated = power = I^2R

Sol.29 [C]

Commercial unit of electrical energy is KWh

Sol.30 [A]

Rate of consumption of electrical energy.

EXERCISE-3

Sol.1 [B]

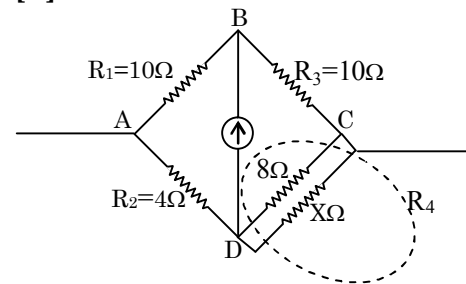

For Balanced bridge

$$\frac{R_1}{R_2} = \frac{R_3}{R_4}$$

$$\frac{10}{4} = \frac{10}{R_4}$$

$$R_4 = 4\Omega$$

$$R_4 = \frac{8 \times X}{8 + X} = 4$$

$$X = 8\Omega$$

Sol.2 [A]

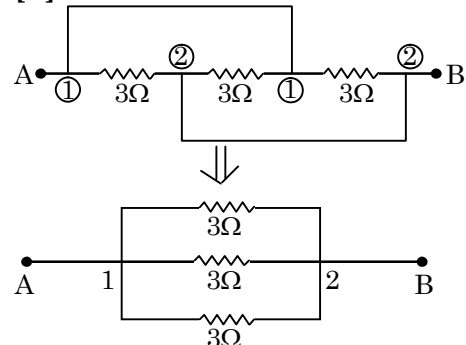

$$\frac{1}{R} = \frac{1}{3} + \frac{1}{3} + \frac{1}{3} \Rightarrow R = 1\Omega$$

Sol.3 [B]

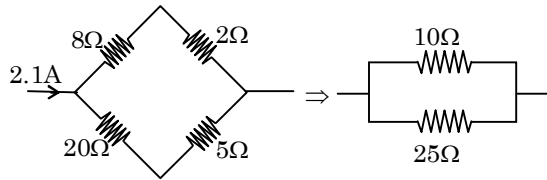

$$\frac{1}{R} = \frac{1}{10} + \frac{1}{25}$$

$$R = \frac{25 \times 10}{25 + 10} = \frac{250}{35}$$



$$R = \frac{250}{35} \Omega$$

Applying ohm's law $V = IR$

$$V = 2.1 \times \frac{250}{35}$$

$$V = 15V$$

Applying ohm's law across arm (20Ω, 5Ω)

$$V = IR$$

$$15 = I \times 25$$

$$I = 0.6A$$

Sol.4 [B]

Electric press \rightarrow large amount of heat is required so that it should have high melting point.

It should not glow like heater so the specific resistance should be low.

Sol.5 [B]

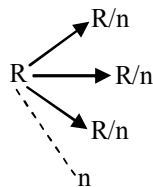

$$\frac{1}{R_{eq}} = \frac{n}{R} + \frac{n}{R} \dots n$$

$$\frac{1}{R_{eq}} = \frac{n^2}{R}$$

$$R_{eq} = R/n^2$$

$$H = \frac{V^2}{R}$$

$$H^1 = \frac{V^2}{R^1} = \frac{V^2}{R/n^2} = n^2 \left(\frac{V^2}{R} \right)$$

$$H^1 = n^2 H$$

Sol.6 [C]

$$V = \frac{W}{Q} = \frac{1J}{1C}$$

Sol.7 [A]

As we know

$$P = \frac{V^2}{R}$$

$$\Rightarrow R = \frac{V^2}{P}$$

$$= \frac{220 \times 220}{60}$$

$$= 806.67\Omega$$

$$\& P = VI$$

$$60 = 220 \times I$$

$$I = \frac{6}{22} = 0.27 A$$

Sol.8 [C]

Due to Rubbing between comb and hairs, there is transfer of electrons.

Sol.9 [A]

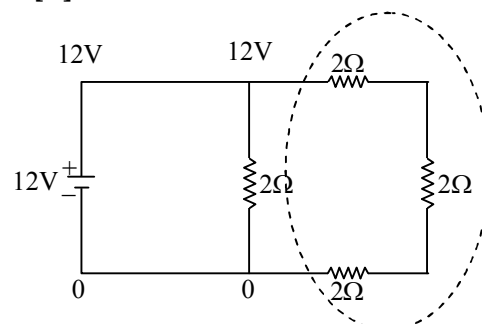

Voltage across all three is 12V .

Since all resistances are same, voltage will be equally divided. i.e. 4v on each resistance.

$$V = IR$$

$$12 = I \times (2 + 2 + 2)$$

$$I = 2A$$

Sol.10 [A]

$$\frac{w}{q} = \frac{1J}{1c} = 1v$$

Sol.11 [C]

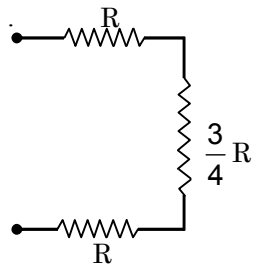
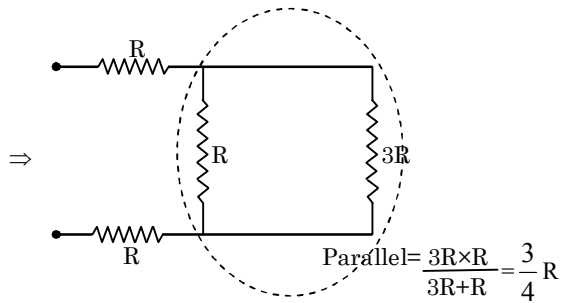
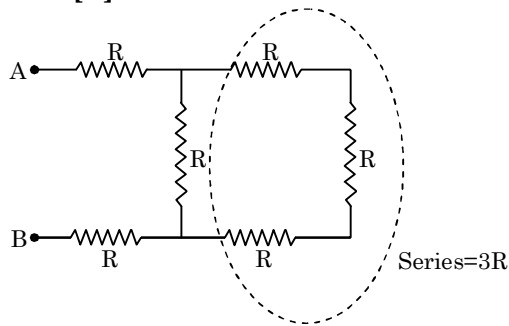

$$R_{eq} = R + R + \frac{3}{4}R$$

$$= \frac{11}{4}R$$

Sol.12 [B]

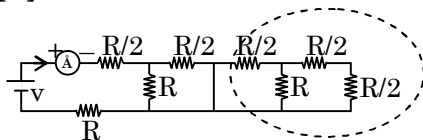

This portion of circuit is short-circuited.

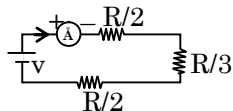

$$R_{eq} = \frac{R}{2} + \frac{R}{3} + \frac{R}{2} = \frac{3R + 2R + 3R}{6}$$

$$= \frac{8R}{6} = \frac{4R}{3}$$

$$I = V/R = \frac{3V}{4R}$$

Sol.13 [D]

$$\text{Energy} = \text{power} \times \text{time}$$

$$200 \text{ units} = 200 \text{ kWh} \quad (1\text{h} = 60 \times 60 \text{ sec})$$

$$= 200 \times 10^3 \times 60 \times 60$$

$$= 7.2 \times 10^8 \text{ J}$$

Sol.14 [B]

$$I = \text{due to neon} + \text{due to flow of electron}$$

$$1.12 = \frac{4.8 \times 10^{18} \times 1.6 \times 10^{-19}}{1} + \frac{n \times 1.6 \times 10^{-19}}{1}$$

$$n \times 1.6 \times 10^{-19} = 0.352$$

$$n = 2.2 \times 10^{18}$$

Sol.15 [A]

Since all the resistance are same and connected in series combination then voltages will be equally divided. i.e. 5V

Sol.16 [B]

$$R = \frac{\rho \ell}{A}$$

For small R $\ell \rightarrow$ small
 $A \rightarrow$ high

Sol.17 [A]

$$V = IR \quad (\text{Across parallel combination voltage is same})$$

$$I = \frac{15}{6} = 2.5 \text{ A}$$

Sol.18 [A]

Resistivity is independent of dimension

Sol.19 [B]

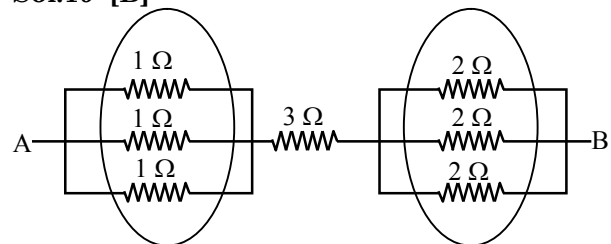

Parallel

$$\frac{1}{R} = \frac{1}{1} + \frac{1}{1} + \frac{1}{1}$$

$$R = \frac{1}{3}$$

Parallel

$$\frac{1}{R} = \frac{1}{2} + \frac{1}{2} + \frac{1}{2}$$

$$R = \frac{2}{3}$$

$$R_{eq} = \frac{1}{3} + 3 + \frac{2}{3} \Rightarrow \frac{1+9+2}{3} = 4\Omega$$

Sol.20 [A]

$$\text{Energy consume} = \text{Power} \times \text{Time}$$

$$= 4 \times (100 \times 6 \times 30)$$

$$= 72\text{kwh}$$

$$\text{Cost} = \text{unit} \times \text{time}$$

$$= 72 \times 5$$

$$360 \text{ Rs}$$

Sol.21 [D]

$$P = I^2R$$

$$I^1 = I + \frac{50}{100} I = 1.5 I$$

$$P^1 = (1.5I)^2 R = 2.25I^2R$$

$$\% \text{ Change} = \frac{\text{Change}}{\text{Initial}} \times 100$$

$$= \frac{2.25I^2R - I^2R}{I^2R} \times 100$$

$$= 125\%$$

Sol.22 [A]

There resistance is zero.

Sol.23 [C]

$$1\text{kwh} = (1 \times 10^3) \times (60 \times 60) \text{ Joules}$$

$$= 3.6 \times 10^6 \text{ Joules}$$

Sol.24 [C]

I = due to Neon + due to election

$$8 = \frac{40 \times 10^8 \times 1.6 \times 10^{-19}}{1} + \frac{n \times 1.6 \times 10^{-19}}{1}$$

$$n = \frac{1.6}{1.6 \times 10^{-19}} = 10^{19}$$

NOTES

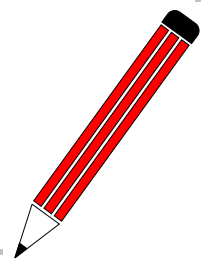

CHEMISTRY

CHEMICAL REACTIONS AND EQUATIONS

Chapter Outline

- ✧ Physical Change
- ✧ Chemical Change
- ✧ Chemical Reactions
- ✧ Chemical Equations
- ✧ Balancing of Equations
- ✧ Types of Chemical Reactions
 - ◆ Combination Reaction
 - ◆ Decomposition Reaction
 - ◆ Displacement Reaction
 - ◆ Double Displacement Reaction
 - ◆ Redox Reaction
- ✧ Oxidation Number
- ✧ Oxidation & Reduction in Day to Day Life



Experimentation

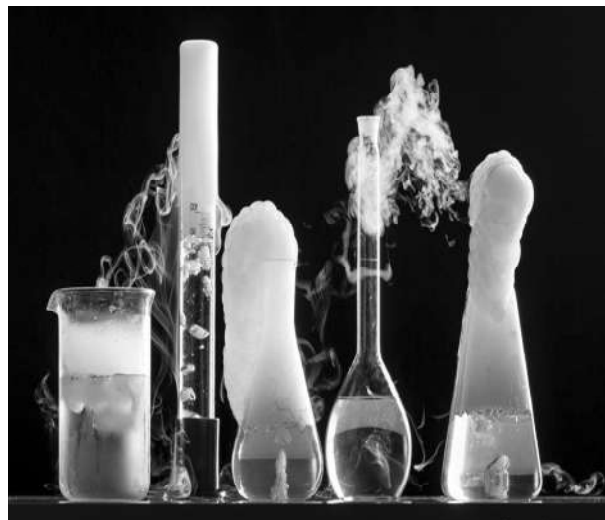

Chemical reactions

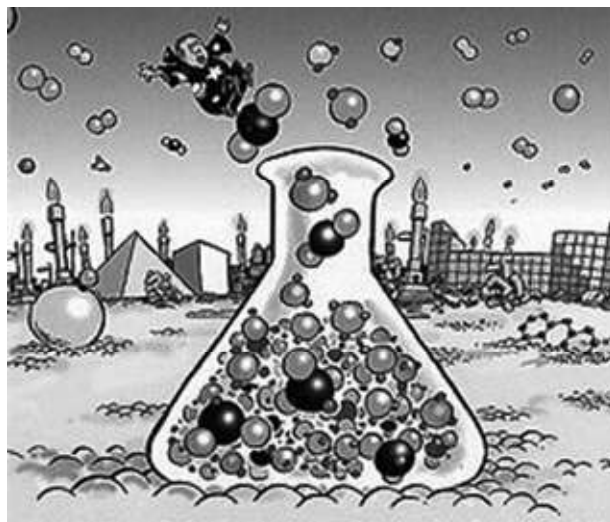

Chemical reactions

MIND MAP

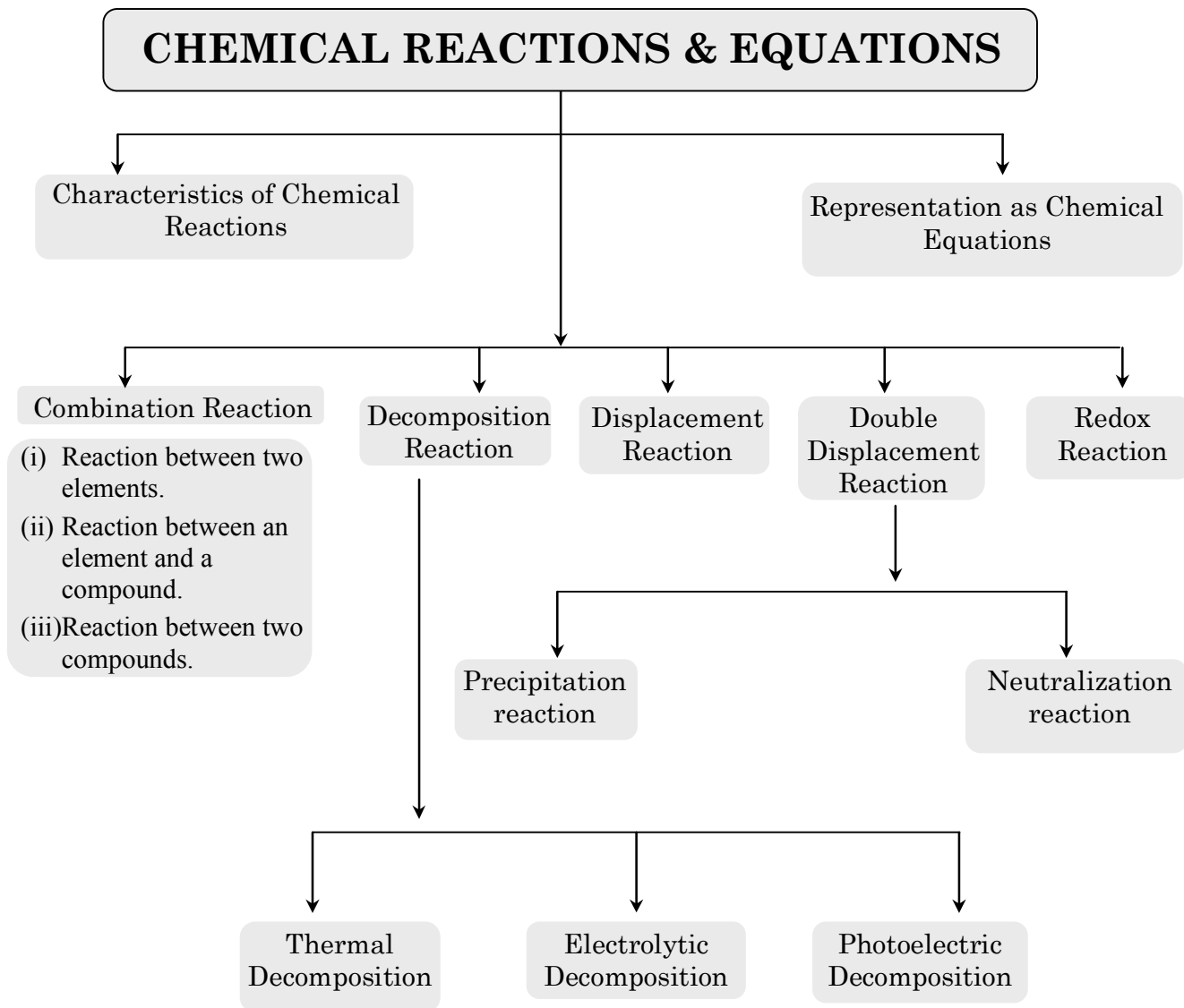

CHEMICAL REACTIONS AND EQUATIONS

Introduction

Chemistry is defined as the branch of science which deals with the study of matter, dealing with the composition, structure, properties and changes occurring in matter.

Changes occurring in matter may be physical changes like melting of wax, freezing of water or may be chemical changes. In this chapter we will discuss chemical changes occurring in matter.

Physical Change

A change which alters some specific physical properties of matter, like its state, texture, magnetic or electrical condition or its colour, without causing any change in the composition of the substance is called physical change.

e.g.: Boiling of water, dissolving of salt in water, ringing of electric bell etc.

Chemical Change

A change which alters the specific properties of a material by bringing a change in its molecular composition is called a chemical change.

e.g.: Formation of curd, burning of wood, etc.

Chemical Reactions

The process involving a chemical change is called a chemical reaction.

◆ Process Involved in Chemical Reactions

During chemical reaction, a rearrangement of atoms takes place between the reacting substances to form new substances having entirely different properties.

Chemical reactions involve breaking of chemical bonds present in the reactant molecules and forming new chemical bonds to give the products. Thus, a chemical reaction simply involves rearrangement of atoms.

The substances which take part in a chemical reaction are called *reactants* while the new substances produced as a result of chemical reaction are called *products*.

Few examples of chemical reactions in daily life:

- (i) Burning piece of paper.
- (ii) Curdling of milk.
- (iii) Rusting of iron articles such as pan or nails.
- (iv) Fermentation of grapes.
- (v) Cooking of food.
- (vi) Digestion of food takes place in our body.
- (vii) We respire.
- (viii) Burning of candle wax.
- (ix) Burning of fuels like kerosene oil, petrol, LPG, etc.

◆ Characteristics of Chemical Reactions

There are some characteristics by which we can identify the occurrence of a chemical reaction. These are described below:

1. **Evolution of gas:** Some of the chemical reactions occur with the evolution of a gas or a mixture of gases.

For example:

- (i) Metals like zinc, magnesium, iron, etc., react with dilute hydrochloric acid with the evolution of hydrogen gas.

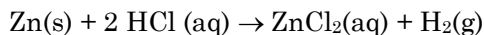

- (ii) When lead nitrate is heated, it gets decomposed to give a solid residue to lead monoxide with the evolution of nitrogen dioxide and oxygen gases.

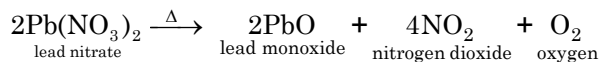

- (iii) When calcium carbonate is treated with hydrochloric acid, gives calcium chloride with evolution of colourless and odourless gas carbon dioxide.



- (iv) When carbon disulphide is treated with oxygen, it form Carbon dioxide and Sulphur dioxide.

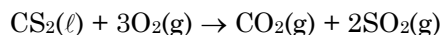

2. **Formation of precipitate:** Sometimes, when two solutions are mixed together, a solid gets separated from the solution. The solid, thus, separated is called the precipitate.

For example:

- (i) When an aqueous solution of sodium sulphate is mixed with a solution of barium chloride, a white precipitate of barium sulphate is produced.

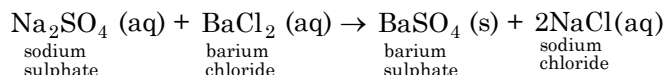

- (ii) When the aqueous solutions of lead acetate and potassium iodide are mixed, a yellow precipitate of lead iodide is produced.

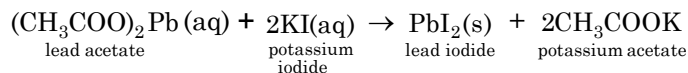

3. **Change in temperature:** Change in temperature is a necessary characteristic of a chemical reaction. On the basis of change in temperature, reactions are of two types –

- ♦ **Exothermic:** Exothermic reactions are those which are accompanied with release of energy.

For example:

- (i) When quicklime (calcium oxide) is treated with water in a beaker, a large quantity of heat is produced. As a result, the beaker becomes very hot. Such reactions in which heat is produced are called exothermic reactions.

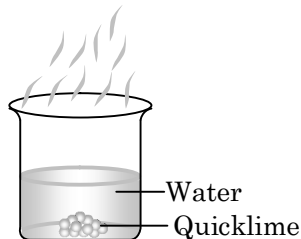
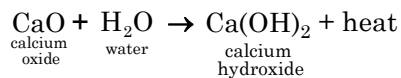

- (ii) $\text{CH}_4(\text{g}) + 2\text{O}_2(\text{g}) \rightarrow \text{CO}_2(\text{g}) + 2\text{H}_2(\text{g}) + \text{Energy}$
Methane

- (iii) $\text{C}_6\text{H}_{12}\text{O}_6(\text{aq}) + 6\text{O}_2(\text{g}) \rightarrow 6\text{CO}_2(\text{g}) + 6\text{H}_2\text{O} + \text{Energy}$
Glucose

- (iv) $2\text{Mg}(\text{s}) + \text{O}_2(\text{g}) \rightarrow 2\text{MgO}(\text{s}) + \text{Heat}$
Magnesium oxide

- ◆ **Endothermic:** Endothermic reactions are those which are accompanied with absorption of energy.

For example:

- (i) When ammonium chloride and barium hydroxide are mixed together in a test tube and the mixture is stirred with a glass rod, the bottom of the test tube becomes cold. In this reaction, heat is absorbed. Such a reaction is called an endothermic reaction.

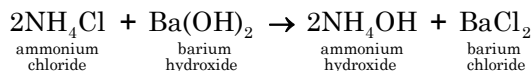

- (ii) $\text{N}_2(\text{g}) + \text{O}_2(\text{g}) + \text{Heat} \rightarrow \underset{\text{Nitric oxide}}{2\text{NO}}$

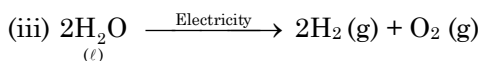

4. **Change in colour:** In some chemical reactions a change in colour is observed.

For example:

- (i) When lead nitrate (colourless) is made to react with potassium iodide (colourless), yellow coloured ppt of lead iodide is formed.

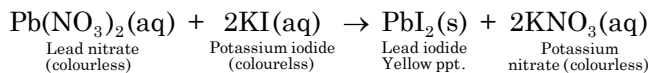

- (ii) When iron (grayish black) is left exposed to air for a long time, the outer surface of iron gets covered with a brown coating of rust.

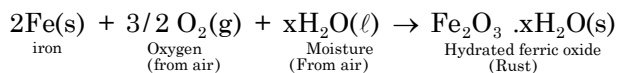

5. **Physical state:** In some reactions the physical state of the product becomes different from that of the reactant.

For example:

- (i) Magnesium ribbon (crystalline) is burnt it changes to white powder of magnesium oxide.

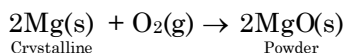

- (ii) Coal burns to form carbon dioxide which is gaseous.

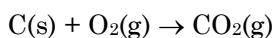

One or more of the above characteristics can certify that a chemical reaction is occurring.

◆ Conditions for a Chemical Reaction

The important conditions for a chemical change (chemical reaction) to take place is as follows:

- 1. Close contact of reactants:** A chemical change (chemical reaction) occurs when the reactants molecules responsible for the change are brought closer to each other.
- 2. Exchange of energy:** The chemical changes take place by exchange of energy in some form, i.e., evolution or absorption of energy in some form.
 - (i) **Heat:** A large number of chemical reactions show evolution or absorption of heat. For example, lime stone (CaCO_3) does not decompose at room temperature but on heating to about 1000°C , it undergoes a chemical change to form lime (CaO) and carbon dioxide (CO_2).

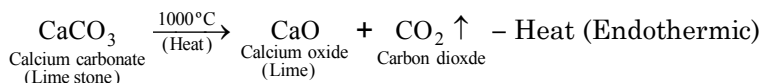

Similarly carbon burns in air to release heat

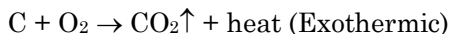

However in many of the exothermic reactions, heat is initially provided to reactant molecules in order to activate them for reaction.

(ii) Light: Some chemical reactions take place with absorption or emission of light. The reactant molecules, on absorbing light, get activated and interact with one another to bring in a chemical change.

For example, a mixture of hydrogen (H₂) and chlorine (Cl₂) undergoes a chemical change to form hydrogen chloride (HCl) when exposed to sunlight.

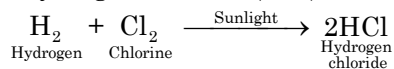

Note: Similarly emission of light by fire flies is due to oxidation of luciferrin protein of their wings. Phosphorus left out of burnt bodies after their cremation, reacts with atmosphere to glow in dark nights. The light so emitted is called cold light.

(iii) Electricity: Several chemical reactions are noticed by passing electric current through the reactants either in the molten state or in the solution form or electricity is produced as a result of chemical change. For example, when electric current is passed in molten sodium chloride, two new substances-sodium and chlorine are obtained (electrolysis). In electrochemical cell say Daniel cell electricity is produced as a result of chemical reaction.

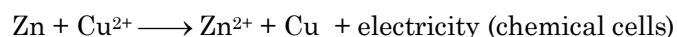
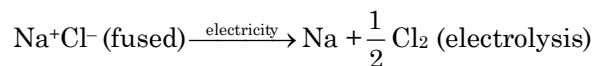

3. Presence of catalyst: Catalysts are the substances which influence the rate of a chemical reaction and remains unchanged in amount and chemical composition at the end of the reaction. Their physical state may change. There are several very slow chemical reactions which require certain catalysts to show an appreciable extent of reaction. For example, potassium chlorate decomposes appreciably to give oxygen and potassium chloride in the presence of manganese dioxide as catalyst. If manganese dioxide is not used, the decomposition occurs at a much higher temperature.

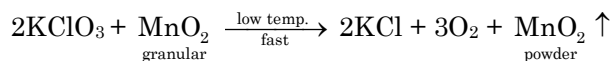
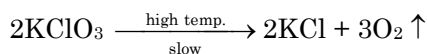

Ex.1 What is the role of a catalyst in a chemical reaction?

Sol. Catalyst helps in increasing the rate of reaction and hence reaction becomes fast.

Ex.2 On what basis is a chemical equation balanced?

Sol. A chemical equation is balanced on the basis of law of conservation of mass according to which mass can neither be created nor be destroyed.

Chemical Equations

The method of representing a chemical reaction with the help of symbols and formulae of the substances involved in it is known as a *chemical equation*.

There are two ways of representing a chemical reaction:

1. In Terms of Words (Called Word Equation): Zinc metal reacts with dilute sulphuric acid to form zinc sulphate and hydrogen gas. This reaction can be written in words as

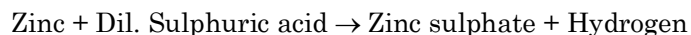

This is known as the word equation.

2. **In Terms of Symbols and Formulae (Called Symbol Equation):** By putting the symbols and formulae of all the substances in the above word equation, we get the following chemical equation.

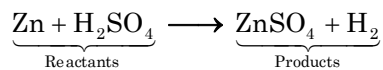

This is called a chemical equation.

◆ Writing of a Chemical Equation

To represent a chemical equation we write:

- The symbols and formulae of the reactants towards the left hand side (LHS) with plus sign between them.
- The symbols and formulae of the products towards the right hand side (RHS) with plus sign between them.
- An arrow (\rightarrow) sign is put between the reactants and the products, pointing from reactants towards products.

◆ Balanced and Unbalanced Chemical Equations

A balanced chemical equation has equal number of atoms of different elements in the reactants and products.

For example:

Zinc + Sulphuric acid \rightarrow Zinc sulphate + Hydrogen

The above word equation may be represented by the following chemical equation

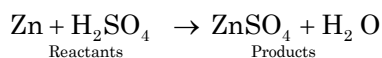

Let us examine the number of atoms of different elements on both sides of the arrow.

Element	Number of atoms in reactants (LHS)	Number of Atoms in products (RHS)
Zn	1	1
H	2	2
S	1	1
O	4	4

As the number of atoms of each element is the same on both sides of the arrow, the above equation is a balanced chemical equation.

An unbalanced or skeletal equation is one in which the number of atoms of different elements (one or more) is not equal on the two sides of the equation.

For example:

Potassium chlorate \rightarrow Potassium chloride + Oxygen

The above word equation may be represented as

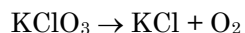

Let us examine the number of atoms of different elements in the unbalanced equation.

Element	Number of atoms in reactants (LHS)	Number of atoms in products (RHS)
K	1	1
Cl	1	1
O	3	2

As the number of atoms of K and Cl are equal on both sides but O-atoms are not equal on both sides, hence the above equation is unbalanced.

Balancing of a Chemical Equation

Balancing of a chemical equation means making the number of each element equal on both sides of the equation.

◆ **Importance of a Balanced Chemical Equation:** The importance of a balanced chemical equation lies in the fact that it satisfies the law of conservation of mass, i.e., in a chemical reaction, total mass of all the products is equal to the total mass of all the reactions.

◆ **Steps Involved in the Balancing of a Chemical Equation:**

The balancing of a chemical equation involves counting up the number of atoms of each element on both sides and trying to equalize them.

The following steps are involved in the balancing of a chemical equations:

Step-I: To write the word equations: Write the chemical equation in the form of a word equations. Keep the reactants on left hand side (LHS) and the products on the right hand side (RHS). Separated them by an arrow (\rightarrow) head of which points from the reactants towards the products.

Step-II: To write the skeletal chemical equation: Write down the symbols and formulae of the various reactants and products. This gives us the skeletal chemical equation.

Step-III: Enclose the formula of each reactant and product in a box. Do not change anything inside the boxes while balancing equation.

Step-IV: List the number of atoms of different elements on LHS (Reactants) and RHS (Products) in the unbalanced equation.

Step-V: Select the biggest formula to start balancing: It is often convenient to start balancing with the compound that contains the maximum number of atoms. It may be a reactant or a product.

Step-VI: To start balancing different elements: Having selected the compound with the biggest formula, first balance the element of this compound. Then balance other elements one by one. To balance the atoms of an element put a whole number coefficient before the formula of the compound.

If selection of the biggest formula appears inconvenient, balance the atoms of that element which occurs at minimum number of places on both sides of the equation. Atoms of the element which occur at maximum places are balanced last of all.

Step-VII: To check the correctness of the balanced equation: Finally, to check the correctness of the balanced equation, count atoms of each element on both sides of the equation. If the number of atoms of elements on both sides of the equation are equal then the equation is balanced.

The method of balancing chemical equation is called **Hit and Trial Method** as we make trial to balance the equation by using the smallest whole number coefficient.

Ex.3 Combustion of methane in oxygen to form carbon dioxide and water.

Sol. Step-I: Writing the equation in word form:

Methane + Oxygen \rightarrow Carbon dioxide + Water

Step-II: Writing the skeletal equation:

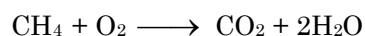

Step-III: Selecting the element which occurs at minimum number of places, i.e. C or H.

No. of C-atoms is same on LHS & RHS.

No of H-atoms is 4 on LHS and 2 H-atoms of RHS. To balance H-atoms, multiply H_2O on RHS by 2, we get,

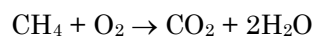

Step-IV: To balance O-atoms: There are 4 O-atoms on RHS and 2 O-atoms on LHS. To balance O-atoms, multiply O_2 on LHS by 2, we get,
 $CH_4 + 2O_2 \rightarrow CO_2 + 2H_2O$

Step-V: To check the corrections of the balanced equation:

Element	Number of atoms on LHS	Number of atoms on RHS
C	1	1
H	4	4
O	4	4

Since, the number of atoms of each element on both sides of the equation is same, the equation is balanced.

Hence, the balanced equation is: $CH_4 + 2O_2 \rightarrow CO_2 + 2H_2O$

Ex.4 Nitrogen and hydrogen combine to form ammonia.

Sol. Step-I: Writing the chemical equation in the word form:

Nitrogen + Hydrogen \rightarrow Ammonia

Step-II: Writing the skeletal chemical equation:

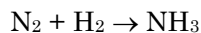

Step-III: Balancing of atoms on both sides: There are 2 N-atoms on LHS and 1 N-atom on RHS. To balance N-atoms, multiply, NH_3 on RHS by 2 we get

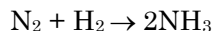

Now, there are 6 H-atoms on RHS and 2 H-atoms on LHS. To balance H-atoms, multiply H_2 on LHS by 3, we get,

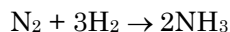

Step-IV: To check the correctness of the balanced equations:

Element	Number of atoms of on LHS	Number of Atoms on RHS
N	2	2
H	6	6

Since, the number of atoms of each element is equal on both sides of the equation, it is balanced. Hence, the balanced equations is: $N_2 + 3H_2 \rightarrow 2NH_3$

COMPETITIVE LEVEL

◆ **Information provided by a balanced chemical equations:**

A skeletal equation provides only qualitative aspect of a chemical reaction. On the other hand, balanced chemical equation provides both qualitative and quantitative aspects.

Qualitative aspect of a chemical equation tells only which reactants are taking part in the reaction and which products are being formed in it.

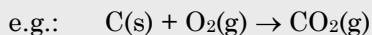

The reaction suggests that solid carbon reacts with oxygen gas on heating to give carbon dioxide in gaseous form.

Quantitative aspect of a chemical equation provides the following information:

The stoichiometric ratio in which reactants are used and products are formed. The mole concept allows us to use the quantitative information available in a balanced chemical equation. The quantitative aspect, dealing with mass and volume relations among reactants and products is termed stoichiometry (derived from a Greek word meaning to measure an element).

Consider for example, the reaction represented by a balanced chemical equation:

Chemical Equation:

	$2\text{H}_2(\text{g})$	+	$\text{O}_2(\text{g})$	→	$2\text{H}_2\text{O}(\text{g})$
Mole ratio:	2 mol		1 mol		2 mol
	or		or		or
Molecule:	$2 \times 6.023 \times 10^{23}$		6.023×10^{23}		$2 \times 6.023 \times 10^{23}$
ratio	or		or		or
	2 molecules		1 molecules		2 molecules
Mass ratio:	4g		32 g		36 g
Volume ratio:	2 vol		1 vol		2 vol

(Volume ratio is valid only for gaseous state at same P and T)

The given reaction suggest for the combination ratio of reactants and formation ratio of products in terms of:

- (a) **Mole ratio:** 2 mol H_2 reacts with 1 mol O_2 to form 2 mol H_2O vapours.
- (b) **Molecular ratio:** 2 molecule H_2 reacts with 1 molecule O_2 to form 2 molecules H_2O vapours.
- (c) **Mass ratio:** 4 g H_2 reacts with 32 g O_2 to form 36 g of H_2O vapours.
- (d) **Volume ratio:** In gaseous state 2 volume H_2 reacts with 1 volume O_2 to form 2 volume H_2O vapours at same conditions of Pressure and Temperature.

It is thus, evident that the coefficients in a balanced chemical equation can be interpreted as the relative number of moles, molecules or volume (if reactants are gases) involved in the reaction. These coefficients are called stoichiometric equivalent.

◆ **Limitations of a Chemical Equation:** It gives no information about the following:

- (i) The physical state of the reactants
- (ii) The concentration of the reactants.
- (iii) The conditions necessary to start and carry on the reaction e.g.: is any catalyst required.
- (iv) Is the reaction exothermic or endothermic, i.e., is heat evolved or absorbed during the reaction.
- (v) Reversibility or irreversibility of a reaction.

◆ **Modification Made for Improvement in Chemical Equations:**

Several modifications are introduced for making chemical equation more informative and more useful.

- (i) **The physical state of reactants and products:** The physical state of the reactants and products are specified by putting letters 's' (for the solid state), 'l' (for the liquid state) and 'g' (for the gaseous state) or 'aq' (for the aqueous solution) in parentheses just after the chemical formula of the reactant or the product which needs to be specified. Sometimes if a gas is evolved in a reaction it is shown by putting the symbol (\uparrow) of an arrow pointing upwards. Similarly if any precipitate is formed during the reaction, it is indicated by putting the symbol (\downarrow) of an arrow pointing downwards.

For example,

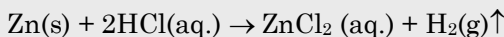
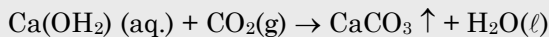
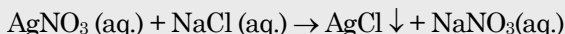
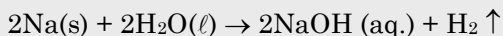
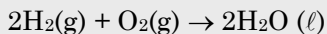

(ii) The concentration of an acid or a base:

The strength of an acid or a base solution is expressed by writing dil. for a dilute solution and conc. for a concentrated solution. For example,

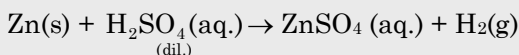

(iii) Favourable conditions of the reactions: The conditions at which a given reaction is made are mentioned on the row between reactants and products.

For example,

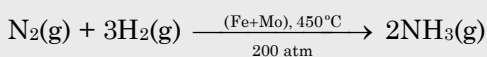

This equation signifies that the nitrogen and hydrogen combines at 450°C and 200 atmospheric pressure in the presence of a catalyst iron (Fe) and promoter molybdenum (Mo).

(iv) Heat changes in the reaction:

Exchange of heat takes place during chemical reactions and therefore heat evolved or absorbed in a chemical reaction should be represented accordingly with their unit.

• **Evolution of heat:**

Reactants \rightarrow Products + Heat

For example,

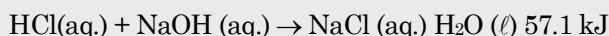

• **Absorption of heat:**

Reactants \rightarrow Products – Heat

For example,

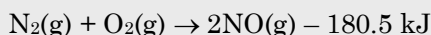

(v) Reversibility or irreversibility of a reaction:

This can be represented by use of different arrows in the equation. Double headed (\rightleftharpoons) or a double half headed (\rightleftharpoons) arrow is used for reversible while single headed (\longrightarrow) arrow is used for irreversible reactions.

• **Reversible reactions:**

For example,

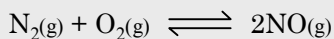
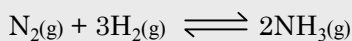

- **Irreversible reactions:**

For example,

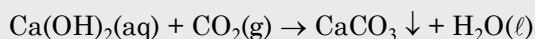

- ♦ **Limitations that are not rectified:**

(i) Rate of reaction:

To represent a slow and a fast reaction usually slow or fast is written on the arrow.

Time involved in the reactions.

(iii) Precautions to be taken during the reactions.

Types of Chemical Reactions

The chemical reactions can broadly be classified into following types:

- (1) Combination reaction
- (2) Decomposition reaction
- (3) Displacement reaction
- (4) Double displacement reaction
- (5) Redox reaction

1. Combination Reaction:

The chemical reaction involving combination of two or more reactants (elements or compounds) to form a single new product is called combination reaction.

Note: A reaction made to obtain a product by using two or more elements is usually referred as synthesis of that compound. Thus combination reaction is also known as synthesis reaction.

Combination reaction like other reactions also involves the exchange of energy i.e., heat, light electricity, pressure or catalyst e.g.:

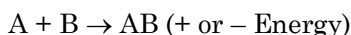

Where, A and B are reactants while AB is the product.

- ♦ **Combination reaction between two elements-**

(i) Hydrogen burns in an atmosphere of oxygen, to form water only.

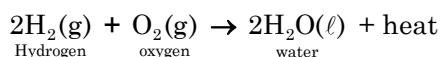

(ii) Combination of hydrogen and chlorine to form hydrogen chloride.

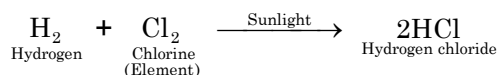

(iii) Combination of sulphur and oxygen to form sulphur dioxide.

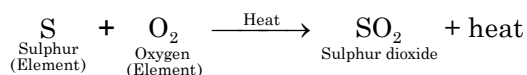

- ♦ **Combination reaction between a compound and an element-**

(i) Combination of carbon monoxide and hydrogen to form methyl alcohol.

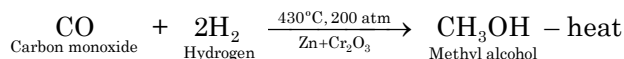

(ii) Combination of carbon dioxide with carbon to form carbon monoxide.

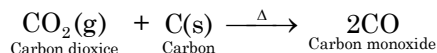

(iii) Combination of nitric oxide and oxygen to form nitrogen dioxide.

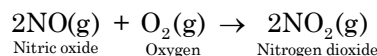

♦ **Combination reaction between two compounds-**

(i) Dissolution of sulphur trioxide in water to form sulphuric acid.

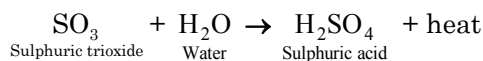

(ii) Dissolution of quick lime in water to form lime water.

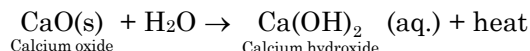

The lime water solution, when applied to the walls of building for white washing, reacts slowly with $\text{CO}_2(\text{g})$ present in air and forms thin shining layer of CaCO_3 on the walls.

(iii) Combination of ammonia and chlorine to give ammonium chloride.

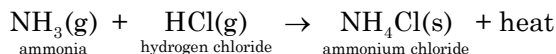

2. Decomposition Reaction:

The chemical reaction in which a compound is broken up into two or more simpler substances (elements or compounds) is called a decomposition reaction.

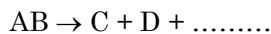

A single reactant AB decomposes to give simpler products like C, D etc.

Note: Decomposition reactions in which a compound breaks down into its constituent elements, is called analysis reactions.

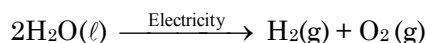

Decomposition reaction involves absorption of energy e.g.: heat, light or electricity. Heat, light and electricity are different form of energy and causes breaking of bonds in the molecules of reactants to yield simpler products.

On the basis of form of energy which is supplied for decomposition, decomposition reactions can be classified as:

♦ **Thermal decomposition:** The decomposition reactants involving absorption of heat are called thermal decomposition reactions.

(i) **Thermal decomposition of mercuric oxide:** Mercuric oxide on heating strongly decomposes to give mercury and oxygen.

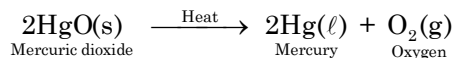

Experiment: Mercuric oxide a red coloured solid on heating decomposes to give shining droplets of mercury with the evolution of oxygen gas.

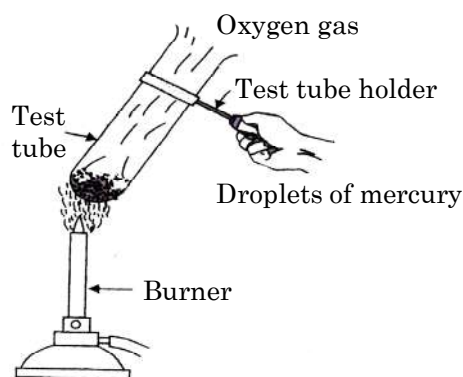
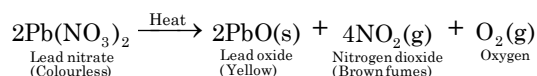

Fig. Heating of mercuric oxide

(ii) Thermal decomposition of lead nitrate:



Experiment: About 2 gram of lead nitrate is taken in a hard glass test tube, holding it by a test tube holder and heat is over a burner. Brown fumes of nitrogen dioxide gas are noticed at the mouth of the test tube and lead oxide is left behind in the test tube in the form of a yellow solid.

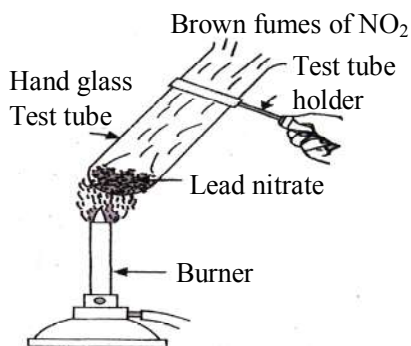
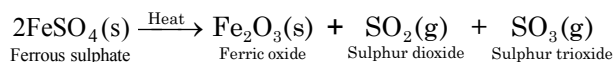

Fig. Thermal decomposition of lead nitrate

(iii) Thermal decomposition of ferrous sulphate: Ferrous sulphate on heating undergoes thermal decomposition to give ferric oxide, sulphur dioxide and sulphur trioxide changing its green colour to brown along with smell of sulphur (SO₂ gas).



Experiment: Green crystals of ferrous sulphate are of ferrous sulphate heptahydrate (FeSO₄.7H₂O). About 2 gram of these crystals are heated in a tube over the flame of a burner (figure). The green colour of the ferrous sulphate crystals first changes to white and then to brown solid (Fe₂O₃). A gas with smell of burning sulphur evolves from the mouth of the test tube.

♦ **Electrolytic Decomposition Reaction:**

A chemical reaction involving decomposition of a compound by the passage of electric current (direct current) is called electrolytic decomposition. This phenomenon is also known as electrolysis.

(i) Electrolytic decomposition of water: On passing electric current through acidified water, decomposition of water yields hydrogen gas and oxygen gas.

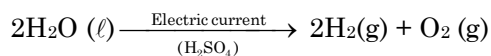

Electrolytic decomposition of water to hydrogen and oxygen is also termed as Electrolysis of water.

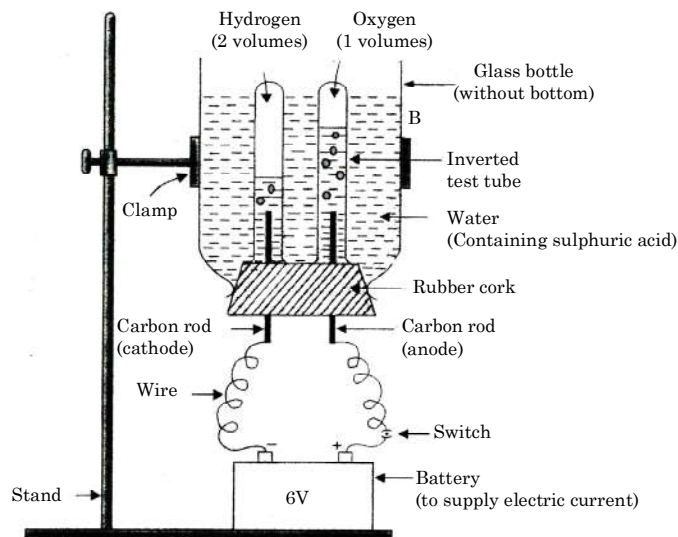
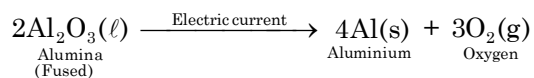
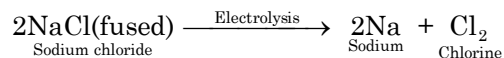

Fig. Electrolysis of acidified water

(ii) Electrolytic decomposition of alumina:



(iii) Electrolysis of fused sodium chloride:



♦ **Photochemical Decomposition Reaction:**

A chemical reaction involving decomposition by the action of light is called a photochemical decomposition reaction.

(i) Photochemical decomposition of silver chloride: Silver chloride on exposing to sunlight undergoes photochemical decomposition forming silver metal and chlorine gas.

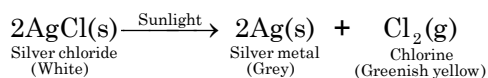

(ii) Photochemical decomposition of silver bromide: Silver bromide on exposing to sunlight also undergoes photochemical decomposition to give silver metal (grey) and bromine vapours (brown).

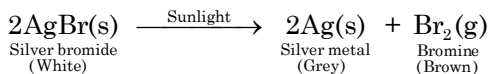

Ex.5 Why should a magnesium ribbon be cleaned before burning in air?

Sol. When magnesium ribbon remains exposed in moist air, a white layer of magnesium oxide is formed on its surface. This hinders the burning of magnesium. Hence, this layer is first removed by rubbing with sand paper before burning.

Ex.6 A solution of a substance 'X' is used for white washing

- (i) Name the substance 'X' and write its formula.
- (ii) Write the reaction of the substance 'X' named in (i) above with water.

Sol. (i) The substance 'X' used for white washing is quick lime (calcium oxide). The formula is CaO.

(ii) When quick lime is mixed with water, the following reaction takes place:

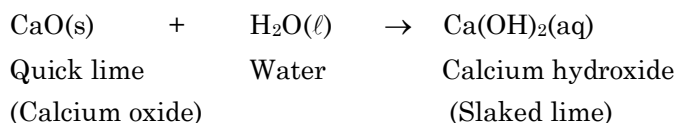

The white suspension of slaked lime is applied on the walls. It combines with carbon dioxide of the air forming a thin shining layer of calcium carbonate.

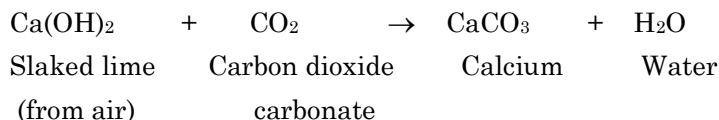

3. Displacement Reaction: The chemical reactions in which an element displaces some other element from a compound are called displacement reaction.

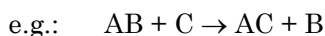

Where, an element C displaces another element B from the compound AB.

(i) **Displacement of copper by iron from copper sulphate solution:** A piece of iron if placed in aqueous copper sulphate solution, the former displaces copper from the later.

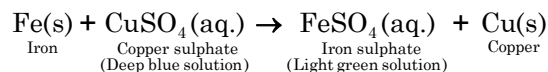

The blue coloured solution of copper fades away due to formation of light green coloured ferrous sulphate solution.

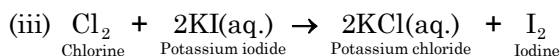
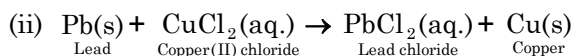

Note: The displacement of an element by some other element is related to activity of metal expressed in terms of activity series or electrochemical series.

4. Double displacement Reaction: The chemical reactions involving two compounds reacting together and forming two new compounds by exchanging one of their ion is called a double displacement reaction.

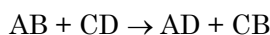

Two compounds AB and CD react together to form two new compounds AD and CB due to mutual exchange of ions. The ion A^+ of AB combines with ion D^- of CD to form a new compound AD. Similarly, the ion C^+ of CD combines with B^- of AB to form another new compound CB.

♦ The double displacement reactions involving the formation of a precipitate are also called **precipitation reactions**.

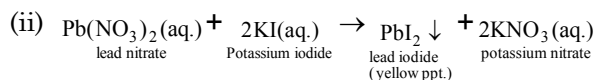
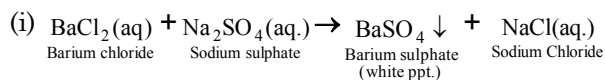

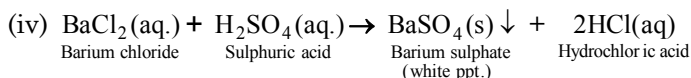
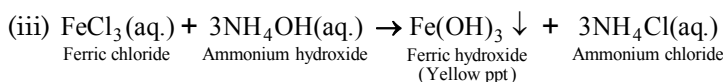

♦ *Double displacement reactions involving acids and bases are called **neutralization reactions**.*

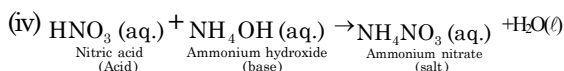
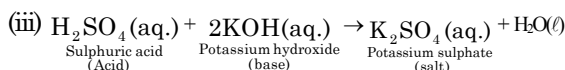
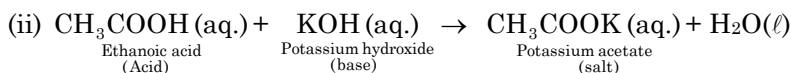
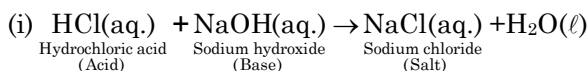

Ex.7 When you mix the solutions of lead (II) nitrate and potassium iodide.

- (i) What is the colour of the precipitate formed? Name the compound precipitated.
- (ii) Write the balanced chemical equation for this reaction.
- (iii) Is this also a double displacement reaction?

Sol. (i) Colour of the precipitate formed is yellow. The compound formed is lead iodide (PbI₂).

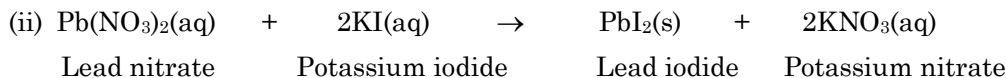

(iii) Yes, it is a double displacement reaction.

Ex.8 Why does the colour of copper sulphate change when an iron nail is dipped in it?

Sol. Iron is more reactive than copper. It displaces copper from copper sulphate solution according to the following reaction:

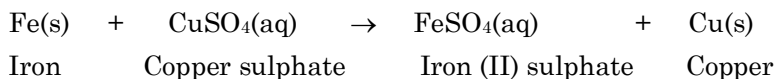

Ex.9 Give an example each of the following types of displacement reactions:

- (i) metal displaces metal
- (ii) non-metal displaces non-metal

Sol. (i) The reaction in which a metal displaces another metal.

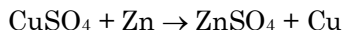

(ii) The reaction in which a non-metal displaces another non-metal.

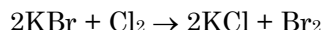

5. Oxidation – Reduction Reaction: (Redox Reaction):

The reactions in which oxidation and reduction occur simultaneously are called redox reactions. There are various concepts of oxidation and reduction.

♦ **Oxidation and reduction in terms of gain or loss of oxygen or hydrogen:**

- **Oxidation** is defined as a process which involves:

(i) gain of oxygen.

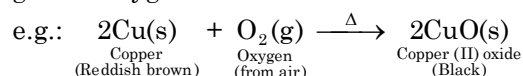

(ii) loss of hydrogen.

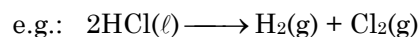

- **Reduction** is defined as a process which involves:

(i) gain of hydrogen.

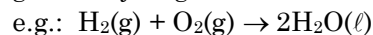

(ii) loss of oxygen.

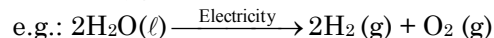

COMPETITIVE LEVEL

♦ **Electronic interpretation of Redox Reactions:**

- **Oxidation** is defined as a process which involves loss of electron.

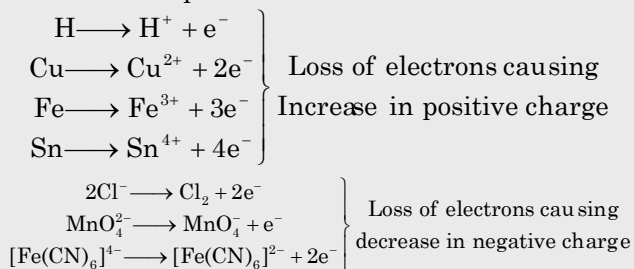

- **Reduction** is defined as a process which involves gain of electron.

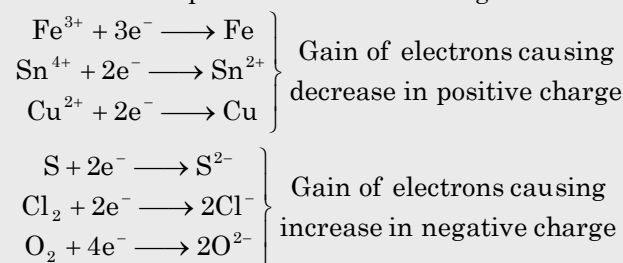

♦ **Oxidation and reduction in terms of gain or loss of electronegative or electropositive substance:**

- **Oxidation** is defined as a process which involves:

(i) Gain of electronegative substance

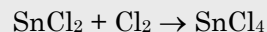
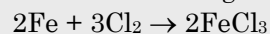

(ii) Loss of electropositive substance

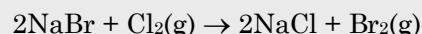
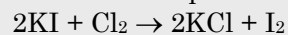

- **Reduction** is defined as a process which involves:

(i) Gain of electropositive substance

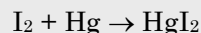
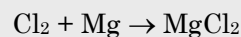

(ii) Loss of electronegative substance

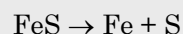

◆ Oxidizing and Reducing Agents

A substance which helps the other substance to undergo oxidation is called an oxidizing agent. Similarly, a substance which helps the other substance to undergo reduction is called a reducing agent.

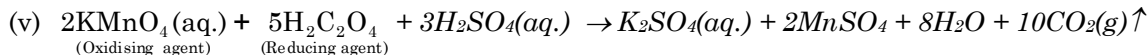
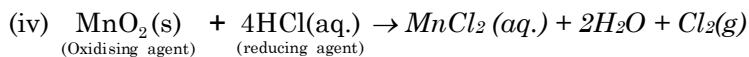
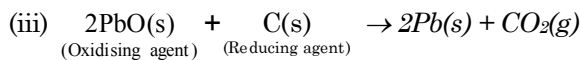
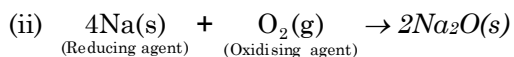

Ex.10 Identify the substances that are oxidised and the substances that are reduced in the following reactions.

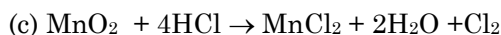
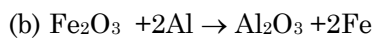
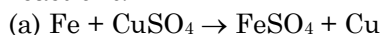

Sol.	(a) Fe	-	Oxidised	Cu	-	Reduced
	(b) Fe ₂ O ₃		Reduced	Al	-	Oxidised
	(c) MnO ₂	-	Reduced	HCl	-	Oxidised

COMPETITIVE LEVEL

Oxidation Number

Definition: Oxidation number of atom in a molecule or a polyatomic ion is a hypothetical charge the atom would have if the electrons in each bond were located on the more electronegative atom.

Oxidation number may be integer, can be positive, negative or zero.

◆ **Calculating oxidation number:**

Following rules must be considered for calculating oxidation number.

Rule 1 : The oxidation number of each atom in an elemental molecule is always zero.
e.g.: Oxidation number of N, O, Cl, F, H, Na in N₂, O₂, Cl₂, F₂, H₂, Na is zero.

Rule 2 : The sum of oxidation number of all atoms in a molecule is always zero.

Rule 3 : The sum of oxidation number of all atoms in an anion is equal to the total charge present on an ion.

Rule 4 : The more electronegative element in a molecule or ion has a negative oxidation number while the less electronegative has positive oxidation number.

Rule 5 : The oxidation number of H in most of its compounds is +1.

Rule 6 : The oxidation number of O in most of its compounds is -2.

Rule 7 : The oxidation number of F in all of its compounds is always -1.

Rule 8 : Oxidation number of alkali metals (Li, Na, K, Rb, Cs, Fr) is + 1.

Rule 9 : Oxidation number of alkaline earth metals (Be, Mg, Ca, Sr, Ba) is + 2.

Rule 10 : Oxidation number of halogens (Cl, Br, I, At) is usually -1.

Formula	Oxidation number	Name
Cu ₂ O	+1	Cuprous oxide
CuF ₂	+2	Cupric fluoride
FeS	+2	Ferrous sulphide
Fe ₂ O ₃	+3	Ferric oxide
SnCl ₂	+2	Stannous chloride
SnCl ₄	+4	Stannic chloride
PbO	+2	Plumbous oxide
PbO ₂	+4	Plumbic oxide
Hg ₂ Cl ₂	+1	Mercurous chloride
HgCl ₂	+2	Mercuric chloride
H ₂ SO ₃ H ₂ SO ₄	+4 +6	2 – units Sulphurous acid Sulphuric acid
HNO ₂ HNO ₃	+3 +5	2 – units Nitrous acid Nitric acid
HBrO ₂ HBrO ₃	+3 +5	2 – units Bromous acid Bromic acid
HClO	+1	Hypochlorous acid
H ₃ PO ₂	+1	Hypophosphorus acid
HIO	+1	Hypoiodous acid
H ₂ N ₂ O ₂	+1	Hyponitrous acid
HClO ₄	+7	Perchloric acid
HBrO ₄	+7	Perbromic acid
HIO ₄	+7	Periodic acid
HClO	+1	Hypochlorous acid
HClO ₂	+3	Chlorous acid
HClO ₂	+5	Chloric acid
HClO ₄	+7	Perchloric acid

Oxidation and Reductions in Day-to-Day Life

Redox changes are important reactions which influence our day-to-day life in several ways. Some of its examples such as burning of fuels, digestion of food in our body etc. are boon to mankind and are very helpful in sustaining life. On the other hand, some of its effects are quite damaging also e.g.: burning of fuels causing air pollution, rancidification of food, corrosion of metals etc.

◆ Useful Effects of Oxidation

- 1. Combustion Reaction:** Kerosene, coal, charcoal, wood etc. burn in air and undergo combustion. Methane (CH₄) a major constituent of natural gas undergoes combustion in excess of oxygen upon heating.

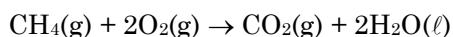

Methane

Similarly, butane (C₄H₁₀) a main constituent of L.P.G. also undergoes combustion.

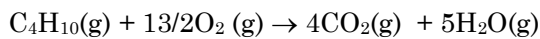

Butane

All combustion reactions are exothermic and redox reactions in nature and release heat energy. The human body may be regarded as a furnace or machine to which various food stuffs that we eat undergo combustion or oxidation. The heat energy evolved keeps our body working. Carbohydrates such as glucose, fructose, starch etc, are the major source of energy to the human body. They undergo combustion with the help of oxygen that we inhale to form carbon dioxide and water. For

Example.



All combustion reactions are not accompanied by flame. Combustion is basically oxidation accompanied with release of energy.

2. **Respiration:** It is the most important biochemical reaction which releases energy in the cells. When we breathe in air, oxygen enters in our lungs and passes into thousands of small air sacs (alveoli). These air sacs occupy a large area of membranes and oxygen diffuses from the membranes into blood. It binds itself to haemoglobin present in red blood cells and is carried to millions of cells in the body. Respiration occurs in these cells and is accompanied by the combustion of glucose producing carbon dioxide and water. Since the reaction is exothermic, the energy released during respiration carry out many cell reactions and also keeps our heart and muscles working. It also provides the desired warmth to the body. Both carbon dioxide and water pass back into the blood and we ultimately breathe them out. Respiration takes place in the cells of all living beings.

◆ Harmful Effects of Oxidation

1. **Corrosion:** Some metals on exposure to a certain environment may get deteriorated due to its reaction with the environment and its surface may become rough and tarnished.

"The process of slowly eating up of the metals due to attack of atmospheric gases such as oxygen, carbon dioxide, hydrogen sulphide, water vapour etc. on the surface of the metals so as to convert the metal into oxide, carbonate, sulphide etc. is known as **corrosion**."

Corrosion is basically an electrochemical phenomenon. The corrosion is defined as the process of slow oxidation of metals into their undesirable compounds (usually oxides) by the action of moisture and other gases present in atmosphere.

For Example :

- (i) When we open the bonnet of a car after a long time, we find a deposit around the terminals of the battery. This is an example of corrosion.



- (ii) Black coating on the surface of silver due to the formation of Ag₂O and Ag₂S.

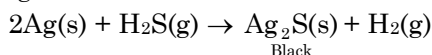

- (iii) Green layer on the surface of copper terminals of battery due to the formation of basic copper carbonate are the examples of corrosion.

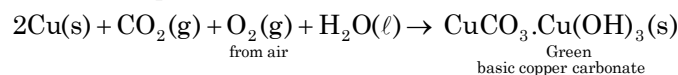

- ◆ **Rusting:** In case of iron, corrosion is called rusting. Rust is hydrated ferric oxide. Fe₂O₃ · xH₂O, brown in colour and is formed by the chemical action of moist air (containing O₂ and H₂O) on iron. It is basically an oxidation reaction and is very slow and once started keeps on going.

Rust is formed by the combined action of air, water and carbon dioxide on iron. The formation of rust involves a redox process and can roughly be described by the following equation:

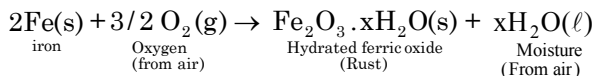

Corrosion is not a desired phenomenon because it tarnishes metals and reduces their strength. Both corrosion and rusting are very harmful and cause damage to the building, railway tracks, cars and other objects materials where metals are used. Corrosion causes damage to iron railings, bridges, ships, car bodies and to all objects made of metal, particularly those of iron.

2. Rancidity: Oxidation has damaging effect on our food and eatables.

The foodstuffs containing fats and oils on storing for a long time, develop unpleasant smell and bad taste due to aerial oxidation of fats and oils. This phenomenon of slow aerial oxidation of fat and oils leading to unpleasant smell and bad taste in them is called 'rancidity' and such fats and oils are said to be rancid'.

The rancid fats and oils give unpleasant smell and bad taste and therefore rancid foodstuffs should not be used as they become harmful to human body.

♦ **Rancidity may be prevented:**

(i) **By using antioxidants:** Manufacturers of food stuffs, sometimes add certain food additives to food material. These substances called antioxidants and prevent oxidation of food stuffs. Butylated hydroxyl toluene (BHT) and butylated hydroxyl anisole (BHA) are commonly used as antioxidants.

(ii) **By using nitrogen during packaging:** Rancidity is caused by the aerial oxidation of fats and oils during storage and thus, if foodstuffs containing fats and oils are placed in absence of air by replacing air using nitrogen atmosphere, they do not get rancid and remains good to eat for a longer period of time. Nitrogen is chemically inert under normal conditions and does not cause oxidation and hence rancidity is prevented. Therefore manufacturing of bags of chips and other eatables are usually packed in nitrogen atmosphere to prevent them from getting oxidised.

(iii) **Keeping the food in refrigerators:** At low temperature oxidation of fats and oils becomes very slow.

(iv) **Keeping the food in air tight containers.**

(v) **Preventing exposure of food to light.**

Ex.11 A shiny brown coloured element 'X' on heating in air becomes black in colour. Name the element 'X' and the black coloured compound formed.

Sol. The element 'X' must be copper. Copper is a shiny brown coloured element which on heating in air combines with oxygen of the air to form black copper oxide

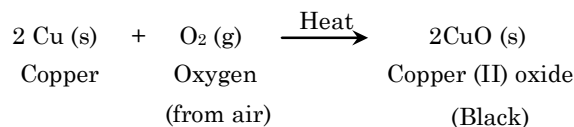

Thus, black coloured compound formed is copper (II) oxide, CuO.

Ex.12 Oil and fat containing food item are flushed with nitrogen. Why?

Sol. In the presence of oxygen of the air, the fats present in the fatty food are oxidized to compounds which have bad smell, i.e., the food becomes rancid. Flushing with nitrogen cuts off oxygen and protects the food from rancidity.

EXERCISE-1

Very Short Answer Type Questions

Q.1 Write balanced equation for the following reaction:

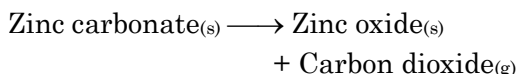

Q.2 Give one example of an electrolytic decomposition.

Q.3 What happens when sodium reacts with water?

Q.4 Why is photosynthesis considered as an endothermic reaction?

Q.5 Give an example of chemical reaction characterized the change in temperature.

Short Answer Type Questions – Type I

Q.6 What is a decomposition reaction? Give example.

Q.7 X, Y and Z are three elements which undergo chemical reactions according to following equations.

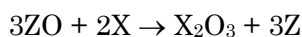
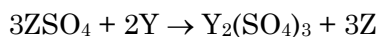
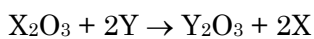

Answer the following equations:

(i) Which element is the most reactive?

(ii) Which element is the least reactive?

Q.8 Potassium chlorate (KClO_3) on heating forms potassium chloride and oxygen. Write a balanced equation for this reaction.

Q.9 On the basis of the following chemical equations, find out which is the least reactive metal amongst iron, copper and zinc?

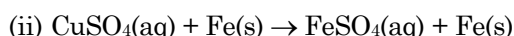
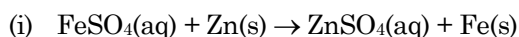

Q.10 What type of chemical equation are the following equations:

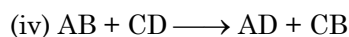
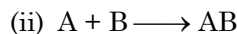
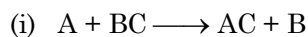

Short Answer Type Questions – Type II

Q.11 How do we come to know that a chemical reaction has taken place?

Q.12 In the following situations, a reaction may or may not take place, If it does, write the balanced equations illustrating the reaction. Assume all involve aqueous solutions.

(i) Some iron nails are placed in a CuCl_2 solutions.

(ii) Silver coins are dropped in a hydrochloric acid solution.

(iii) A copper wire is placed in a $\text{Pb}(\text{NO}_3)_2$ solution.

Q.13 Consider the following chemical equations:

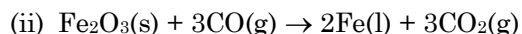
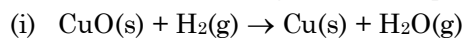

Identify the following in these equations, giving reasons:

(a) The substance getting oxidised.

(b) The substance getting reduced

(c) The oxidising agent

(d) The reducing agent

Q.14 Among the following displacement reactions which one will take place and which one will not occur and why?

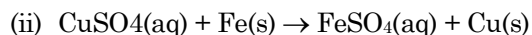
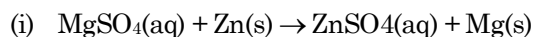

Q.15 What is an oxidation reaction? Give an example of oxidation reaction. Is oxidation an exothermic or an endothermic reaction.

- Q.16** What happens when iron nails are put in copper sulphate solution?
 (i) Write the equation for the reaction that takes place.
 (ii) Name the type of reaction involved.
- Q.17** Why does stale food give a bad taste and bad smell?
- Q.18** Why do silver, gold and platinum not corrode in moist air?
- Q.19** What are the different types of combination reactions?
- Q.20** Why cannot we stir silver nitrate solution with copper spoon?



Long Answer Type Questions

- Q.21** Write any two observations in an activity which may suggest that a chemical reaction has taken place. Give an example in support of your answer.
- Q.22** Balance the following chemical equations:
 (i) $S(s) + H_2SO_4(aq) \longrightarrow H_2O(l) + SO_2(g)$
 (ii) $S(s) + HNO_3(aq) \longrightarrow$
 $H_2SO_4(aq) + NO_2(g) + H_2O(l)$
 (iii) $Fe_2O_3(s) + CO(g) \longrightarrow Fe(l) + CO_2(g)$
 (iv) $KMnO_4(aq) + HCl(aq) \longrightarrow$
 $KCl(aq) + MnCl_2(aq) + Cl_2(g) + H_2O(l)$
 (v) $MnO_2(s) + HCl(aq) \longrightarrow$
 $MnCl_2(aq) + H_2O(l) + Cl_2(g)$
- Q.23** Name the substance oxidized and substance reduced in the following reactions:
 (i) $MnO_2 + 4HCl \rightarrow MnCl_2 + Cl_2 + 2H_2O$
 (ii) $2H_2S + SO_2 \rightarrow 2H_2O + 3S$
 (iii) $2PbO + C \rightarrow 2Pb + CO_2$
 (iv) $PbS + 4H_2O_2 \rightarrow Pb + CO_2$
- Q.24** Explain the effects of oxidation reactions in everyday life.
- Q.25** When a compound of lead is heated, brown coloured fumes evolve from it.
 (i) Name the compound.
 (ii) Write the balanced chemical equation.
 (iii) Write the chemical name of brown coloured fumes.
 (iv) Name the type of reaction.
 (v) Is this reaction an exothermic or endothermic ?

EXERCISE-2

- Q.1** Which of the following changes represents a physical change?
 (A) Conversion of sulphur to sulphur dioxide
 (B) Heating of a metal knife
 (C) Combustion of methane
 (D) Hydrolysis of an ester
- Q.2** Which of the following are exothermic processes?
 (i) Reaction of water with quick lime
 (ii) Dilution of an acid
 (iii) Evaporation of water
 (iv) Sublimation of camphor (crystals)
 (A) (i) and (ii)
 (B) (ii) and (iii)
 (C) (i) and (iv)
 (D) (iii) and (iv)
- Q.3** Which of the following is not an endothermic process?
 (A) Boiling of water
 (B) Dissolution of salts in water
 (C) Dissolution of conc. H_2SO_4 in water
 (D) Evaporation of water
- Q.4** If in the reaction $\text{N}_2(\text{g}) + \text{O}_2(\text{g}) \longrightarrow 2\text{NO}(\text{g})$ the energy required to break nitrogen-nitrogen and oxygen-oxygen bonds is more than twice the energy released during bond formation between nitrogen and oxygen atoms, the reaction is a/an -
 (A) Endothermic reaction
 (B) Double displacement reaction
 (C) Exothermic reaction
 (D) Single displacement reaction
- Q.5** In an endothermic reaction -
 (A) The energy content of products is less than heat content of reactants
 (B) The energy content of products is greater than that of reactants
 (C) Heat is released
 (D) Heat is neither absorbed nor released
- Q.6** Three beakers labeled as A, B and C each containing 25 ml of water were taken. A small amount of NaOH, anhydrous CuSO_4 and NaCl were added to the beakers A, B and C respectively. It was observed that there was an increase in the temperature of the solutions contained in beakers A and B, whereas, in case of beaker C, the temperature of the solution falls. Which one of the following statement (s) is (are) correct?
 (i) In beakers A and B, exothermic process has occurred.
 (ii) In beakers A and B, endothermic process has occurred.
 (iii) In beaker C exothermic process has occurred.
 (iv) In beaker C endothermic process has occurred.
 (A) (i) only (B) (ii) only
 (C) (i) and (iv) (D) (ii) and (iii)
- Q.7** Complete the following statement by choosing correct options for x and y. "During the process of respiration, glucose combines with oxygen in the cells of our body and 'x' a large amount of energy. Hence, respiration is an 'y' process."
 (A)

x	y
releases	endothermic

 (B)

x	y
absorbes	endothermic

 (C)

x	y
releases	exothermic

 (D)

x	y
absorbes	exothermic
- Q.8** A balanced chemical equation is in accordance with -
 (A) Avogadro's law
 (B) Dalton's atomic theory
 (C) The law of conservation of mass
 (D) The law of constant proportion

- Q.9** Which of the following chemical equations is an unbalanced one?
- (A) $2\text{NaHCO}_3 \longrightarrow \text{Na}_2\text{CO}_3 + \text{H}_2\text{O} + \text{CO}_2$
 (B) $2\text{C}_4\text{H}_{10} + 12\text{O}_2 \longrightarrow 8\text{CO}_2 + 10\text{H}_2\text{O}$
 (C) $2\text{Al} + 6\text{H}_2\text{O} \longrightarrow 2\text{Al}(\text{OH})_3 + 3\text{H}_2$
 (D) $4\text{NH}_3 + 5\text{O}_2 \longrightarrow 4\text{NO} + 6\text{H}_2\text{O}$
- Q.10** Which of the following statements is not true for the chemical equation?
- $$2\text{N}_2\text{O}_5 \longrightarrow 4\text{NO}_2 + \text{O}_2$$
- (A) 2 mol of N_2O_5 on dissociation gives 4 mol of NO_2 and 1 mol of O_2
 (B) 1 mol of N_2O_5 on dissociation gives 2 mol of NO_2 and 0.5 mol of O_2
 (C) 2 g of N_2O_5 on dissociation gives 4 g of NO_2 and 1 g of O_2
 (D) 216 g of N_2O_5 on dissociation gives 184 g of NO_2 and 32 g of O_2
- Q.11** Electrolysis of water is a decomposition reaction. The mole ratio of hydrogen and oxygen gases liberated during electrolysis of water is -
- (A) 1: 1 (B) 2: 1
 (C) 4: 1 (D) 1: 2
- Q.12** Take a long magnesium ribbon. Heat it over a flame when it burns with a bright light and is converted into white powder of MgO . It is called a -
- (A) combination reaction
 (B) displacement reaction
 (C) decomposition reaction
 (D) thermal decomposition
- Q.13** Which of the following reactions should be called 'combination' or 'synthesis' reaction?
- (i) $\text{C}(\text{s}) + \text{O}_2(\text{g}) \longrightarrow \text{CO}_2(\text{g})$
 (ii) $\text{CaO}(\text{s}) + \text{CO}_2(\text{g}) \longrightarrow \text{CaCO}_3(\text{s})$
 (iii) $\text{CaO}(\text{s}) + \text{H}_2\text{O}(\text{l}) \longrightarrow \text{Ca}(\text{OH})_2(\text{aq})$
 (iv) $\text{Cu}(\text{s}) + 2\text{AgNO}_3(\text{aq}) \longrightarrow 2\text{Ag}(\text{s}) + \text{Cu}(\text{NO}_3)_2(\text{aq})$
- (A) Reaction (i) only
 (B) Reactions (i) and (ii) only
 (C) Reactions (i), (ii) and (iii) only
 (D) All reactions – (i) to (iv)
- Q.14** Take about 1.0 g CaCO_3 in a test tube. Heat it over a flame, when a colourless gas comes out. The reaction is called a -
- (A) decomposition reaction
 (B) displacement reaction
 (C) double decomposition reaction
 (D) double displacement reaction
- Q.15** Which of the following reactions should be called 'decomposition' reaction?
- (i) $\text{Cu}(\text{OH})_2(\text{s}) \xrightarrow{\text{heat}} \text{CuO}(\text{s}) + \text{H}_2\text{O}(\text{l})$
 (ii) $\text{CH}_4(\text{g}) \xrightarrow{\text{catalyst}} \text{C}(\text{s}) + 2\text{H}_2(\text{g})$
 (iii) $2\text{H}_2\text{O}(\text{l}) \xrightarrow[\text{current}]{\text{electric}} 2\text{H}_2(\text{g}) + \text{O}_2(\text{g})$
 (iv) $\text{CaCO}_3(\text{s}) \xrightarrow{\text{heat}} \text{CaO}(\text{s}) + \text{CO}_2(\text{g})$
- (A) Reaction (i) only
 (B) Reactions (i) and (ii) only
 (C) Reactions (i), (ii) and (iii) only
 (D) All reactions – (i) to (iv)
- Q.16** The following reaction is used for the preparation of oxygen gas in the laboratory:
- $$2\text{KClO}_3(\text{s}) \xrightarrow[\text{catalyst}]{\Delta} 2\text{KCl}(\text{s}) + 3\text{O}_2(\text{g})$$
- Which of the following statement(s) is/are correct about the reaction?
- (A) It is a decomposition and endothermic in nature.
 (B) It is a combination reaction.
 (C) It is a decomposition reaction and accompanied by release of heat
 (D) It is a photochemical decomposition reaction and exothermic in nature
- Q.17** Which of the following is not an example of 'single displacement' reaction?
- (A) $2\text{Al} + \text{Fe}_2\text{O}_3 \longrightarrow \text{Al}_2\text{O}_3 + 2\text{Fe}$
 (B) $\text{Ca} + \text{Cl}_2 \longrightarrow \text{CaCl}_2$
 (C) $2\text{KI} + \text{Cl}_2 \longrightarrow \text{I}_2 + 2\text{KCl}$
 (D) $2\text{Na} + 2\text{H}_2\text{O} \longrightarrow 2\text{NaOH} + \text{H}_2$
- Q.18** Which of the following reactions should be called 'double displacement' reaction?
- (i) $\text{AgNO}_3 + \text{NaBr} \longrightarrow \text{NaNO}_3 + \text{AgBr}$
 (ii) $\text{BaCl}_2 + \text{H}_2\text{SO}_3 \longrightarrow \text{BaSO}_3 + 2\text{HCl}$
 (iii) $\text{Pb}(\text{NO}_3)_2 + \text{H}_2\text{S} \longrightarrow 2\text{HNO}_3 + \text{PbS}$
 (iv) $\text{NaOH} + \text{HCl} \longrightarrow \text{NaCl} + \text{H}_2\text{O}$
- (A) Reaction (i) only
 (B) Reactions (i) and (ii) only
 (C) Reactions (i), (ii) and (iii) only
 (D) All reactions – (i) to (iv)

- Q.19** In the double displacement reaction between aqueous potassium iodide and aqueous lead nitrate, a yellow precipitate of lead iodide is formed. While performing the activity if lead nitrate is not available, which of the following can be used in place of lead nitrate?
 (A) Lead sulphate (insoluble)
 (B) Lead acetate
 (C) Ammonium nitrate
 (D) Potassium sulphate
- Q.20** Which of the species is oxidized in the following redox reaction?

$$\text{Cu(s)} + 2\text{Ag}^+(\text{aq}) \longrightarrow \text{Cu}^{2+}(\text{aq}) + 2\text{Ag(s)}$$
 (A) Cu(s)
 (B) Cu²⁺(aq)
 (C) Ag⁺(aq)
 (D) Ag(s)
- Q.21** The process of reduction involves -
 (A) The absorption of oxygen atoms
 (B) The absorption of electrons
 (C) The release of electrons
 (D) Neither absorption nor release of electrons
- Q.22** Reduction is the process which involves -
 (A) Gain of hydrogen
 (B) Gain of oxygen
 (C) Gain of sulphur
 (D) Gain of phosphorus
- Q.23** The following reaction is an example of a

$$\text{H}_2(\text{g}) + \text{Cl}_2(\text{g}) \rightarrow 2\text{HCl}(\text{g})$$
 (i) Combination reaction
 (ii) Displacement reaction
 (iii) Redox reaction
 (iv) Neutralization reaction
 (A) (i) and (iv) (B) (ii) and (iii)
 (C) (i) and (iii) (D) (iii) and (iv)
- Q.24** In the following oxidation-reduction reaction

$$\text{MnO}_2 + 4\text{HCl} \rightarrow \text{MnCl}_2 + \text{Cl}_2 + 2\text{H}_2\text{O}$$
 the reducing agent is
 (A) Chlorine
 (B) Manganese dioxide
 (C) Hydrochloric acid
 (D) Hydrogen
- Q.25** In the reaction $\text{MnO}_4^- + 8\text{H}^+ + 5\text{Fe}^{2+} \longrightarrow \text{Mn}^{2+} + 5\text{Fe}^{3+} + 4\text{H}_2\text{O}$ the oxidant is-
 (A) MnO₄⁻ (B) H⁺
 (C) Fe²⁺ (D) Fe³⁺
- Q.26** In a reaction, KCl is converted into KClO₄. Oxidation number changes from -1 to ____
 (A) +3 (B) +5 (C) +7 (D) +8
- Q.27** Oxidation number of Cl atoms in CaOCl₂ (bleaching powder)

$$\text{Ca} \begin{cases} \text{Cl}^* \\ \text{ClO}^{**} \end{cases}$$
 (A) zero on-each
 (B) -1 on Cl* and +1 on Cl**
 (C) +1 on Cl* and -1 on Cl**
 (D) 1 on each
- Q.28** In which oxidation number of Cr has been affected?
 (A) $2\text{CrO}_4^{2-} + 2\text{H}^+ \rightarrow \text{Cr}_2\text{O}_7^{2-} + \text{H}_2\text{O}$
 (B) $\text{Cr}_2\text{O}_7^{2-} + 2\text{OH}^- \rightarrow 2\text{CrO}_4^{2-} + \text{H}_2\text{O}$
 (C) $(\text{NH}_4)_2\text{Cr}_2\text{O}_7 \rightarrow \text{N}_2 + \text{Cr}_2\text{O}_3 + 4\text{H}_2\text{O}$
 (D) $\text{CrO}_2\text{Cl}_2 + 2\text{OH}^- \rightarrow \text{CrO}_2^{2-} + 2\text{HCl}$
- Q.29** Prussian blue has two types of iron with oxidation number as shown: Fe [Fe(CN)₆]^{III II}
 What is the net change on Prussian blue?
 (A) -1 (B) +1
 (C) 0 (D) -2
- Q.30** Which Lewis formula is more likely to be correct for Cl₂O?
 (A) Cl - O - Cl
 (B) Cl - Cl - O
 (C) Both (A) and (B)
 (D) None of these

EXERCISE-3

(Previous Year Questions - NTSE & NSO)

- Q.1** The reaction between aqueous solutions of sodium chloride and silver nitrate is –
(A) displacement reaction
(B) synthesis reaction
(C) double displacement reaction
(D) analysis reaction
- Q.2** $\text{CH}_4 + \text{Cl}_2 \rightarrow \text{CH}_3\text{Cl} + \text{HCl}$ reaction is an example of –
(A) Synthetic
(B) Analytical
(C) Displacement
(D) Neutralisation
- Q.3** A Brown and bright element “x” when heated in presence of air turns into black substance “y”. If Hydrogen gas is passed over this heating material again “x” is obtained. “x” and “y” are –
(A) Cu & CuO (B) S & SO₂
(C) C & CO₂ (D) Na & NaH
- Q.4** $\text{H}_2\text{S}(\text{g}) + \text{Cl}_2(\text{g}) \rightarrow 2\text{HCl}(\text{g}) + \text{S}(\text{s})$
The reaction is interpreted as:
(A) H₂S is getting oxidised and Cl₂ is getting reduced
(B) H₂S is getting reduced and Cl₂ is getting oxidised
(C) Only H₂S is oxidised
(D) Both H₂S and Cl₂ are reduced
- Q.5** What is the oxidation number of sulphur in peroxy mono sulphuric acid (H₂SO₅)?
(A) 8 (B) 6
(C) 5 (D) 4
- Q.6** Oxidation is defined as:
(A) loss of electron (B) gain of electron
(C) loss of proton (D) gain of proton
- Q.7** From the following metals whose nitrate produces NO₂ gas on heating?
(A) Na (B) K
(C) Pb (D) None of these
- Q.8** The equation given below indicates
 $\text{NaCl} + \text{AgNO}_3 \rightarrow \text{AgCl} + \text{NaNO}_3$;
(A) Chemical decomposition
(B) Chemical combination
(C) Chemical displacement
(D) Chemical double displacement
- Q.9** Displacement reaction is:
(A) $\text{CaO}(\text{s}) + \text{H}_2\text{O}(\text{l}) \rightarrow \text{Ca}(\text{OH})_2(\text{aq})$
(B) $\text{Pb}(\text{s}) + \text{CuCl}_2(\text{aq}) \rightarrow \text{PbCl}_2(\text{aq}) + \text{Cu}(\text{s})$
(C) $\text{MnO}_2(\text{s}) + 4\text{HCl}(\text{l}) \rightarrow \text{MnCl}_2(\text{s}) + 2\text{H}_2\text{O}(\text{l}) + \text{Cl}_2(\text{g})$
(D) $\text{C}_6\text{H}_{12}\text{O}_6 + 6\text{O}_2 \rightarrow 6\text{CO}_2 + 6\text{H}_2\text{O}$
- Q.10** What is the instrument called for water electrolysis process?
(A) Voltmeter (B) Voltmeter
(C) Hydrometer (D) Lectometer
- Q.11** Which of the following is endothermic reaction?
(A) $\text{C}(\text{s}) + \text{O}_2(\text{g}) \longrightarrow \text{CO}_2(\text{g})$
(B) $\text{N}_2(\text{g}) + \text{O}_2(\text{g}) \longrightarrow 2\text{NO}(\text{g})$
(C) $2\text{H}_2(\text{g}) + \text{O}_2(\text{g}) \longrightarrow 2\text{H}_2\text{O}(\text{l})$
(D) $2\text{CH}_3\text{OH}(\text{l}) + 3\text{O}_2(\text{g}) \rightarrow 2\text{CO}_2(\text{g}) + 4\text{H}_2\text{O}(\text{l})$
- Q.12** In which of the following reactions H₂O₂ acts as a reducing agent:
(a) $\text{H}_2\text{O}_2 + 2\text{H}^+ + 2\text{e}^- \rightarrow 2\text{H}_2\text{O}$
(b) $\text{H}_2\text{O}_2 - 2\text{e}^- \rightarrow \text{O}_2 + 2\text{H}^+$
(c) $\text{H}_2\text{O}_2 + 2\text{e}^- \rightarrow 2\text{OH}^-$
(d) $\text{H}_2\text{O}_2 + 2\text{OH}^- - 2\text{e}^- \rightarrow \text{O}_2 + 2\text{H}_2\text{O}$
(A) (a),(c) (B) (b),(d)
(C) (a),(b) (D) (c), (d)
- Q.13** Precipitate formation during chemical reaction is indicated by this arrow:
(A) ↑ (B) → (C) ↓ (D) ←

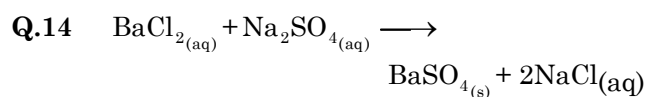

The types of reaction are:

- (a) Displacement
 - (b) Precipitation
 - (c) Combination
 - (d) Double displacement
- (A) (a) & (c) (B) (a), (b), & (c)
(C) (b) & (c) (D) (b) & (d)

Q.15 The chemical reaction
 $\text{HNO}_3 + \text{KOH} \longrightarrow \text{KNO}_3 + \text{H}_2\text{O}$ is an
example of -

- (A) Neutralization
- (B) Double displacement
- (C) Neutralization and double displacement
- (D) Combination

Q.16 Which type of catalyst is glycerol in the following
reaction ? [Raj/NTSE/18/Stage/I/]

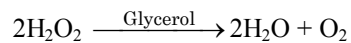

- (A) Positive catalyst
- (B) Negative catalyst
- (C) Biocatalyst
- (D) Autocatalyst

ANSWER KEY

EXERCISE - 2

Ques.	1	2	3	4	5	6	7	8	9	10	11	12	13	14	15
Ans.	B	A	C	A	A	C	C	C	B	C	B	A	C	A	D
Ques.	16	17	18	19	20	21	22	23	24	25	26	27	28	29	30
Ans.	A	B	D	B	A	B	A	C	C	A	C	B	C	A	A

EXERCISE - 3

Ques.	1	2	3	4	5	6	7	8	9	10	11	12	13	14	15
Ans.	C	C	A	A	A	A	C	D	B	A	B	B	C	D	C
Ques.	16														
Ans.	B														

SOLUTIONS

EXERCISE-1

Very Short Answer Type Questions

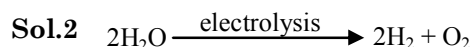
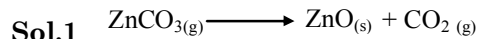

Sol.3 Highly exothermic reaction takes place.

Sol.4 $\text{C}_6\text{H}_{12}\text{O}_6 + 6\text{O}_2 + \text{Energy} \rightarrow 6\text{CO}_2 + 6\text{H}_2\text{O}$
Energy is absorbed so it is endothermic reaction

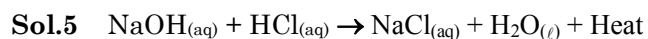

Short Answer Type Questions – Type I

Sol.6 The chemical reaction in which a compound is broken up into two or more simpler substances (elements or compounds) is called a decomposition reaction.

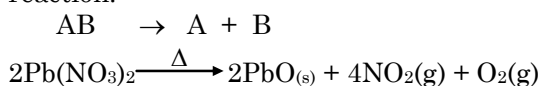

Sol.7 (i) Y
(ii) Z

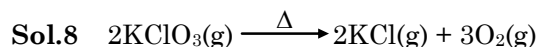

Sol.9 Cu (copper) is least reactive so it will not displace iron and zinc from its salt solution.

Sol.10 (i) Displacement
(ii) Combination
(iii) Decomposition
(iv) Double displacement

Short Answer Type Questions – Type II

Sol.11

- Evolution of gas
- Formation of precipitate
- Change in temperature
- Change in colour
- Change in state

Sol.12 (i) $2\text{Fe}(\text{s}) + 3\text{CuCl}_2(\text{aq}) \rightarrow 2\text{FeCl}_3 + 3\text{Cu}$
Iron is more reactive so it will displace copper from copper chloride

(ii) $\text{Ag}(\text{s}) + \text{HCl}(\text{aq}) \rightarrow \text{NO Reaction}$
Silver is less reactive so it will not displace hydrogen

(iii) $\text{Cu} + \text{Pb}(\text{NO}_3)_2 \rightarrow \text{NO Reaction}$
Copper is less reactive so it will not displace lead from lead nitrate solution

Sol.13 (a) H_2 & CO
(b) CuO & Fe_2O_3
(c) CuO & Fe_2O_3
(d) H_2 & CO

Sol.14 (i) No
Zinc is less reactive than magnesium so it will not displace magnesium from magnesium sulphate.

(ii) Yes.
Iron is more reactive than copper so it will displace copper from copper sulphate and will form iron sulphate.

Sol.15 **Oxidation** is defined as a process which involves:

(i) gain of oxygen.
(ii) loss of hydrogen
(iii) electron is removed

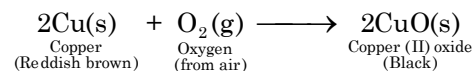

Oxidation Reaction are generally exothermic in nature

Sol.16 (i) $\text{Fe}(\text{g}) + \text{CuSO}_4(\text{aq}) \rightarrow \text{FeSO}_4(\text{aq}) + \text{Cu}$
(ii) Displacement Reaction

Sol.17 Stale food give a bad taste and bad smell due to Rancidity which is caused due to oxidation of fats and oils

Sol.18 silver, gold and platinum not corrode in moist air because they are less reactive metals

Sol.19 (i) Combination reaction between two elements
(ii) Combination reaction between a compound and an element
(iii) Combination reaction between two compounds

Sol.20 We cannot stir silver nitrate solution with copper spoon because silver is less reactive than copper, so copper can displace silver from its compound and the displacement reaction will take place.

➤ Long Answer Type Questions

Sol.21 Change in temperature

Exothermic: Exothermic reactions are those which are accompanied with release of energy.

For example:

When quicklime (calcium oxide) is treated with water in a beaker, a large quantity of heat is produced. As a result, the beaker becomes very hot. Such reactions in which heat is produced are called exothermic reactions.

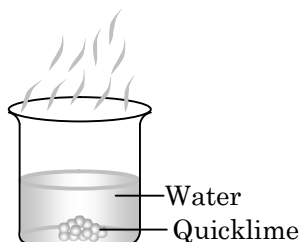
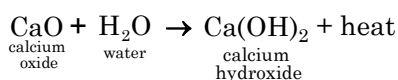

- Sol.22** (i) $\text{S} + 2\text{H}_2\text{SO}_4 \rightarrow 2\text{H}_2\text{O} + 3\text{SO}_2$
(ii) $\text{S} + 6\text{HNO}_3 \rightarrow \text{H}_2\text{SO}_4 + 6\text{NO}_2 + 2\text{H}_2\text{O}$
(iii) $\text{Fe}_2\text{O}_3 + 3\text{CO} \rightarrow 2\text{Fe} + 3\text{CO}_2$
(iv) $2\text{KMnO}_4 + 16\text{HCl} \rightarrow 2\text{KCl} + 2\text{MnCl}_2 + 5\text{Cl}_2 + 8\text{H}_2\text{O}$
(v) $\text{MnO}_2 + 4\text{HCl} \rightarrow \text{MnCl}_2 + 2\text{H}_2\text{O} + \text{Cl}_2$

Sol.23 Substance Oxidized	Substance Reduced
(i) HCl	MnO ₂
(ii) H ₂ S	SO ₂
(iii) C	PbO

Sol.24 (i) Corrosion:

The corrosion is defined as the process of slow oxidation of metals into their undesirable compounds (usually oxides) by the action of moisture and other gases present in atmosphere.

For Example :

(i) When we open the bonnet of a car after a long time, we find a deposit around the terminals of the battery. This is an example of corrosion.

(ii) Rancidity:

This phenomenon of slow aerial oxidation of fat and oils leading to unpleasant smell and bad taste in them is called 'rancidity' and such fats and oils are said to be rancid'.

For Example :

The foodstuffs containing fats and oils on storing for a long time, develop unpleasant smell and bad taste.

- Sol.25** (i) Lead Nitrate
(Pb) (NO₃)₂
(ii) $2\text{Pb}(\text{NO}_3)_2 \xrightarrow{\Delta} 2\text{PbO} + 4\text{NO}_2 + \text{O}_2$
(iii) Nitrogen dioxide
(NO₂)
(iv) Decomposition Reaction
(v) Endothermic

EXERCISE-2

- Sol.1 [B]**
Heating of metal knife
No New substance is formed
- Sol.2 [A]**
(i) & (ii)
 $\text{CaO} + \text{H}_2\text{O} \rightarrow \text{Ca(OH)}_2 + \text{Heat}$
&
Dilution is also exothermic process
- Sol.3 [C]**
Dissolution of conc H₂SO₄ in water
It is exothermic process
- Sol.4 [A]**
(A) Endothermic reaction
absorbed energy > Released energy
∴ Endothermic Reaction
- Sol.5 [A]**
The energy content of products is less than heat content of reactants
Endothermic → Energy_{Product} > E_{Reactant}

Sol.6 [C]

(i) and (iv)

(i) In beakers A & B, Exothermic process has occurred because its temperature has increased

(ii) In beaker C endothermic process has occurred because its temperature has decreased

Sol.7 [C]

x	y
releases	exothermic

Respiration is Exothermic

X Y
↓ ↓

Release Exothermic

Sol.8 [C]

The law of conservation of mass

Balanced chemical equation follows law of Conservation of mass.

Sol.9 [B]

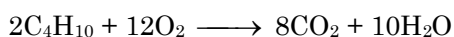

Rest all reaction are balanced.

Sol.10 [C]

2 g of N_2O_5 on dissociation gives 4 g of NO_2 and 1 g of O_2

Validation of law of conservation of mass

Sol.11 [B]

2: 1

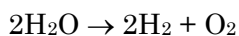

two moles of water gives two moles of hydrogen and one moles of oxygen

Sol.12 [A]

Combination Reaction

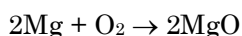

Sol.13 [C]

Reactions (i), (ii) and (iii) only

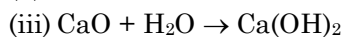
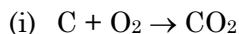

Sol.14 [A]

Decomposition reaction

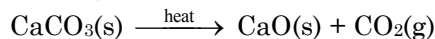

Sol.15 [D]

All reactions – (i) to (iv)

Sol.16 [A]

It is a decomposition and endothermic in nature

Sol.17 [B]

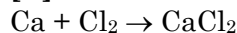

It is an example of combination reaction

Sol.18 [D]

All reactions

Sol.19 [B]

Lead acetate

It has to be a lead salt which is soluble in water.

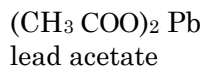

Sol.20 [A]

$Cu(s)$

$Cu \rightarrow$ Oxidised

Loss of electron

Sol.21 [B]

The absorption of electrons

Reduction \rightarrow gain of electron

Sol.22 [A]

Gain of Hydrogen

Sol.23 [C]

(i) and (iii)

(i) Combination

(iii) Redox

Sol.24 [C]

Hydrochloric acid

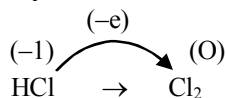

↓
Hydrochloric acid

Oxidation of HCl takes place so it is reducing agent

Sol.25 [A]

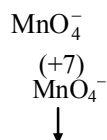

Permanganate

MnO_4^- is reduced so it is oxidizing agent

Sol.26 [C]

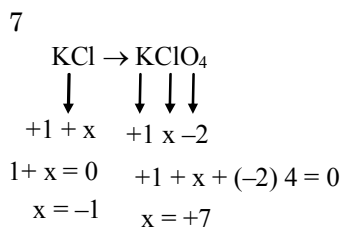

Sol.27 [B]

-1 on Cl* and +1 on Cl**

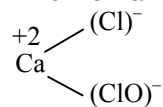

Cl^- & Cl^+

Sol.28 [C]

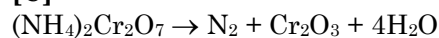

+7 → +3

Cr Cr Reduced

N^{-3} → No Oxidized

Sol.29 [A]

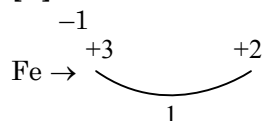

$(\text{CN}) \rightarrow -1 = -1 \times 6 = -6$

$\text{Fe} = +3 + 2 = +5$

Net charge = -1

Sol.30. [A]

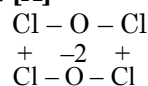

Sol.2 [C]

Displacement

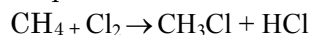

Sol.3 [A]

Cu & CuO

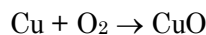

Sol.4 [A]

H_2S is getting oxidised and Cl_2 is getting reduced

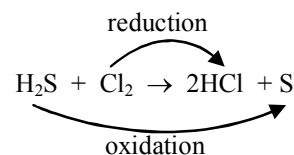

Sol.5 [B]

6

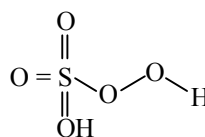

(+6)

Sol.6 [A]

loss of electron

Oxidation is -: loss of e^-
or addition of O

Sol.7 [C]

Pb

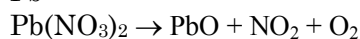

Sol.8 [D]

Chemical double displacement

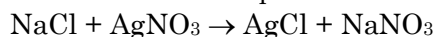

Double displacement

Sol.9 [B]

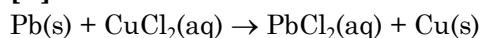

Sol.10 [A]

voltmeter

Sol.11 [B]

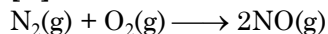

Endothermic

EXERCISE-3

Sol.1 [C]

double displacement reaction

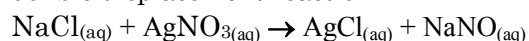

Sol.12 [B]

(b), (d)

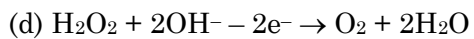
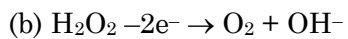

Sol.13 [C]

↓

Precipitate is shown by ↓

Sol.14 [D]

(b) & (d)

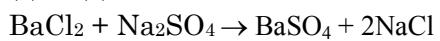

white ppt

Precipitate + Double displacement

Sol.15 [C]

Neutralization and double displacement

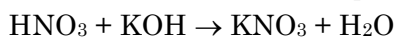

Neutralization + double displacement

Sol.16 [B]

Negative catalyst

NOTES

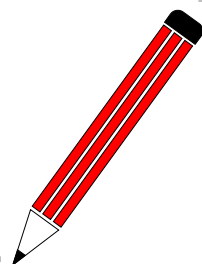

BIOLOGY

NUTRITION

Chapter Outline

- ❖ Nutrition
- ❖ Modes of nutrition
- ❖ Nutrition in plants
- ❖ Nutrition in animals
- ❖ Digestive system of humans

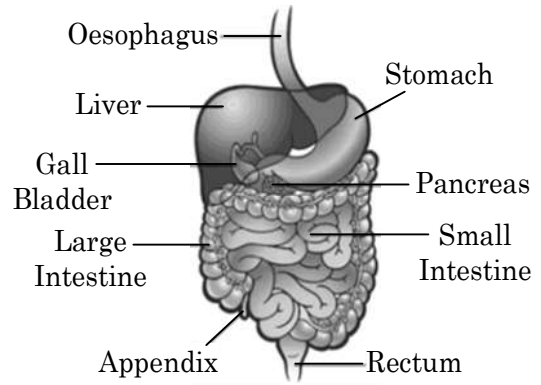

Digestive System

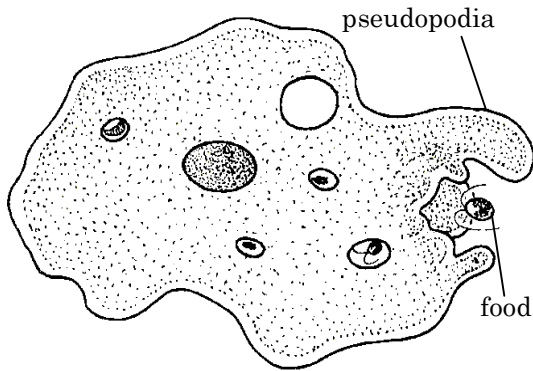

Nutrition of Amoeba

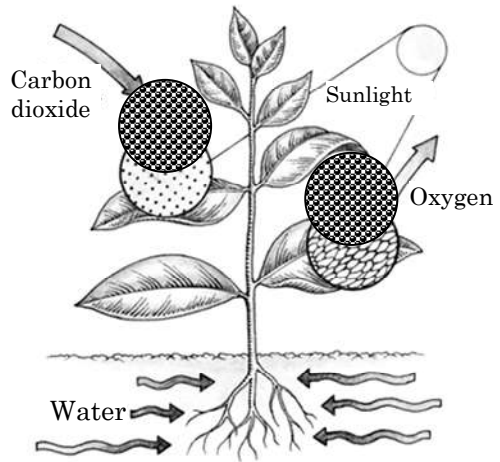

Plant Showing Photosynthesis

MIND MAP

NUTRITION

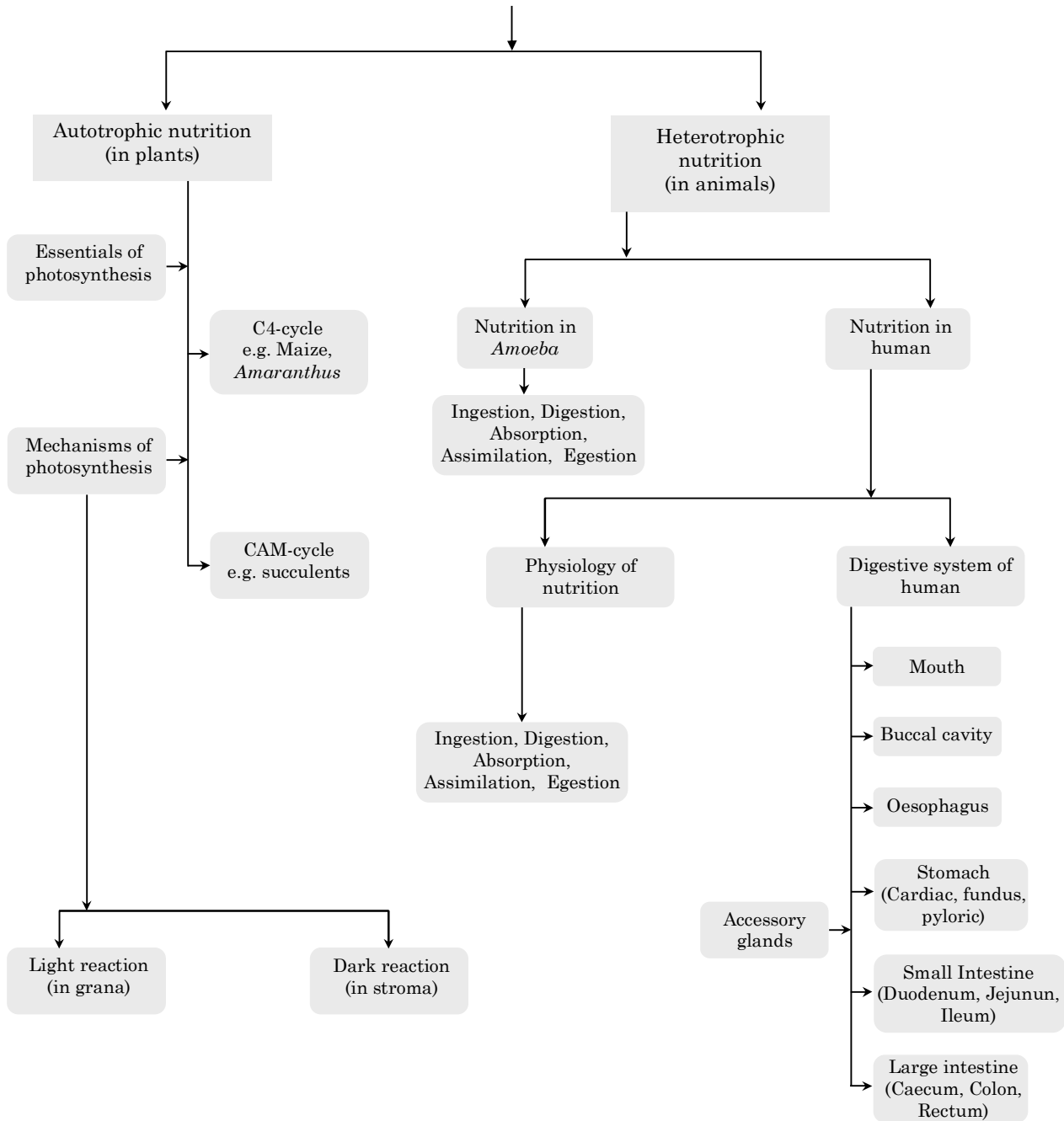

NUTRITION

Nutrition

The process of intake of nutrients & its utilization is called nutrition.

◆ Nutrient :

The different component of food that have distinct functions like

- (i) providing energy
- (ii) providing materials for body building
- (iii) maintenance & regulation of metabolism are called nutrient.

For Example –

- (i) Proteins - Egg, pulses
- (ii) Minerals, Vitamin - Green leafy vegetable
- (iii) Carbohydrates - Wheat
- (iv) Fats - Butter, Oils

Modes of Nutrition

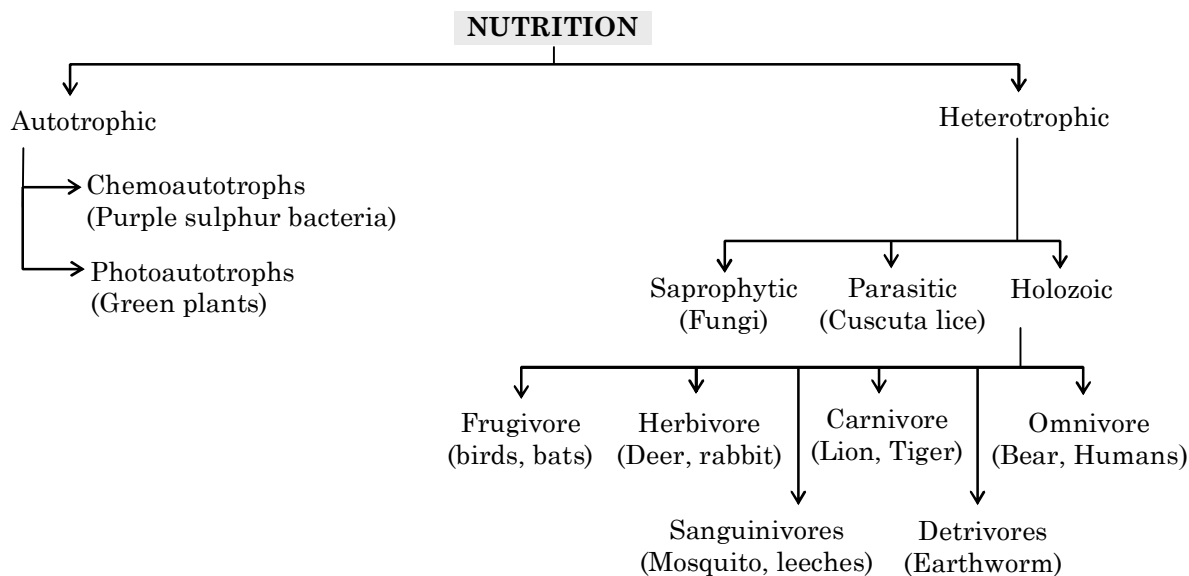

◆ Autotrophic Nutrition : (Gk. *autos*-self, *trophe*-nourishment)

It is a mode of nutrition in which organisms are able to build up their own organic food from inorganic raw materials with the help of energy. The organism performing autotrophic nutrition are called autotrophs.

◆ Heterotrophic Nutrition :

It is a mode of nutrition in which the organisms obtain readymade organic food from outside sources. The organisms that depend upon outside sources for obtaining organic nutrients are called heterotrophs. Heterotrophic nutrition is of three types - saprophytic, parasitic and holozoic.

Ex.1 What kind of nutrition occurs in yeast.

Ans. Saprophytic nutrition

COMPETITIVE LEVEL

- Fats provide the most energy followed by carbohydrates and proteins respectively.
- Proteins are the building blocks of body.
- **Chemoautotrophs** : These organisms use chemical energy for the synthesis of food.
E.g. Purple sulphur bacteria
- **Photoautotrophs** : These organism use light energy for the synthesis of food.
E.g. Green plants
- **Saprophytic or Saprotophic Nutrition** : It is a mode of heterotrophic nutrition in which food is obtained from organic remains like dead organisms, excreta, fallen leaves, broken twigs, food articles, etc.
- **Parasitic Nutrition** : It is a mode of hetrotrophic nutrition in which a living organism flourishes by obtaining food from another living organism.
- **Holozoic Nutrition** : It is a mode of heterotrophic nutrition which involves intake of solid pieces of food.

Nutrition in Plants

◆ Photosynthesis :

Photosynthesis is the primary mode of food production in green plant. " The process by which green plants synthesize food from simple substances i.e. carbon dioxide and water in the presence of light and chlorophyll is called **Photosynthesis**"

The process of photosynthesis can be represented in the form of chemical reaction, as given below :

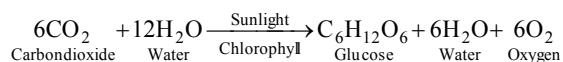

◆ Essential of photosynthesis :

(A) **Sunlight** : For plants sun is the basic source of radiant energy.

(B) **Chlorophyll** : These are the green pigments present in chloroplast. They are found in green leaves in the maximum amount as well as in other green aerial parts of plant.

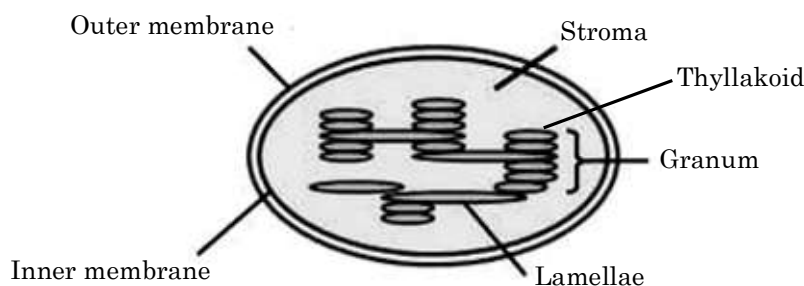

Figure : Chloroplast

(C) **Water** : Plant's roots absorb water from the soil by the process of osmosis (endosmosis). This water is transported to leaves by a special type of tissue called as xylem.

(D) **Carbon Dioxide** : Terrestrial plants obtain carbon dioxide from the atmosphere through the small openings present on leaves called as stomata. 'Stomata' are the small pores present on the surface.

◆ **Opening and Closing Stomata :**

The opening and closing of stomata depend upon the turgid or flaccid state of the guard cells. When guard cells are in turgid state the stomatal aperture opens and when guard cells are in flaccid state the stomatal aperture closes.

The inner wall of guard cells (towards pore) is thick and outer wall (towards other epidermal cells) is thin. When the turgor pressure of the guard cells is increased the outer thinner wall of the guard cell is pushed out (towards the periphery) due to which a tension is created on the inner thicker wall thus pulling the inner thicker wall towards the periphery thus leading to the opening of stomatal aperture.

On the contrary when the guard cells are in a flaccid state the outer thinner wall of guard cells returns to original position (moves towards pore) due to which tension on the inner wall is released which also returns to its original position and stomatal aperture gets closed again.

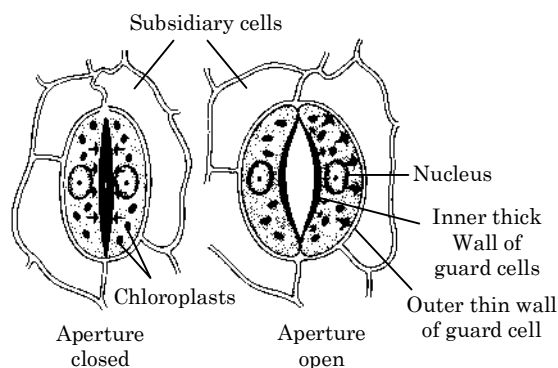

Figure : Stomata

COMPETITIVE LEVEL

- Plants utilize the light in the visible region of solar spectrum (electromagnetic spectrum) which comes under the range of 390 nm – 780 nm wavelength.
- Photosynthetically Active Radiation or PAR refers to radiation with wavelengths between 400 & 700 nm.
- 50% of incident solar radiation is PAR. Plant absorbs only 2-10% of PAR.
- Maximum photosynthesis takes place in white light followed by red and blue light.
- Minimum photosynthesis takes place in green light.
- RuBisCO is the most abundant enzyme.
- Plants utilize the light in the visible region of solar spectra (electromagnetic spectrum) which comes under the range of 390 nm – 780 nm wavelength
- Maximum photosynthesis occurs in red region
- There are six different types of chlorophyll : chl a, b, c, d, e and bacteriochlorophyll. Amongst them chlorophyll a and chlorophyll b are the most commonly occurring chlorophyll.

◆ Mechanism of Photosynthesis :

The following events occur in photosynthesis

- (i) Absorption of light energy by chlorophyll.
- (ii) Conversion of light energy to chemical energy and splitting of water molecules into hydrogen and oxygen.
- (iii) Reduction of carbon dioxide to carbohydrates.

COMPETITIVE LEVEL

◆ Photosynthesis can also be Divided into Two Steps :

(A) Light Reaction :

- It is also called Hill Reaction. As it was discovered by Robert Hill.
- Site - grana of thylakoids
- It is named as light reaction as it occurs only in presence of light.

Major Step :

(i) **Photoexcitation of chlorophyll molecule** : During this process chlorophyll molecule receives sunlight in the form of small energy bundles called as **photons** and becomes excited to higher energy level.

(ii) **Photolysis** : It is also called as photooxidation of water, this takes place in presence of Mn^{+2} and Cl^- ions.

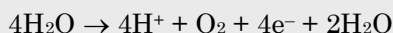

O_2 is liberated as by product and H^+ ions are used for reduction of NADP

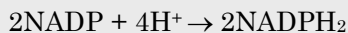

(iii) **Photophosphorylation** : During this process ATP are produced. It takes place in **quantasomes / photosystem**. Inorganic phosphate is required to convert ADP to ATP.

(B) Dark Reaction :

- This reaction is not dependent on light. It is also known as Calvin – Benson Cycle or C_3 cycle as first stable product is phosphoglyceric acid (PGA) a 3 carbon compound.
- **Site** : Stroma of chloroplast

Major Step :

(i) **Carboxylation** : In this CO_2 is captured by CO_2 acceptors like RUBP (C_3 Plants) PEP (C_4 Plants) with the help of **carboxylase enzyme** i.e. **RuBisCO & PEPCo** respectively. The first stable compound of C_3 cycle is a three carbon containing molecule **phosphoglyceric acid** so it is called as C_3 cycle while in C_4 cycle it is four carbon containing **oxalo acetic acid**.

(ii) **Synthesis of glucose** : In this phase captured CO_2 is assimilated into glucose in the presence of phosphatase and isomerase enzyme.

(iii) **Regeneration of RUBP.**

Ex.2 Why are plants green?

Ans. Plants are green due to presence of the green pigment called chlorophyll.

Ex.3 “Plants prepare their own food and are called autotrophs”. What is the name of this process? Why is it called so?

Ans. The process of production of food by plants is called photosynthesis. Photo means light and synthesis means manufacturing, as manufacturing of glucose occurs in the presence of light it is named as ‘photosynthesis’.

Ex.4 Oxygen released during photosynthesis is the outcome of which steps of this process?

Ans. The energy trapped by the chlorophyll molecules is used to breakdown water and released oxygen as a product. This process is called photolysis of water.

COMPETITIVE LEVEL

◆ Crassulacean Acid Metabolism (CAM) :

- Certain plants, especially succulents which grow under extremely xeric (dry) condition, fix atmospheric CO₂ in dark.
- Since the process was first observed in the plants belonging to family crassulaceae (eg. Bryophyllum, kalanchoe etc.) It was termed crassulacean acid metabolism (CAM).
- The most characteristic feature of these plants is that their stomata remain open at night (in dark) but closed during the day (in light).
- Thus, CAM is a kind of adaptation in succulents to carry out photosynthesis without much loss of water.

Nutrition in Animals

◆ Nutrition in Amoeba :

Protozoa carry out holozoic nutrition through intracellular digestion.

(i) Ingestion : Some protozoa can ingest food particle from any point on the surface (e.g., *Amoeba*) while others have fixed points for the same (e.g., *Paramecium*). Protozoans like *Amoeba* capture food with the help of temporary finger-like processes called **pseudopodia**. Protozoans like (*Paramecium* have small hair-like processes called cilia.) Beating of cilia creates current in water that pushes food particle through cytostome or cell mouth. The process of ingestion of solid food particle by a cell or unicellular organism is called **phagocytosis**.

(ii) Digestion : In amoeba, food is digested in the food vacuole by digestive enzymes. These enzymes break down the food into small and soluble molecules by chemical reactions.

(iii) Absorption : The digested food is directly absorbed into the cytoplasm by diffusion. After absorption the food vacuole disappears.

(iv) Assimilation : The absorbed food is used to obtain energy which leads to growth and reproduction of Amoeba.

(v) **Egestion** : Amoeba does not have any fixed place for removing the digested food.

For removal of accumulated wastes or undigested food, the cell membrane ruptures at a place and waste is thrown out.

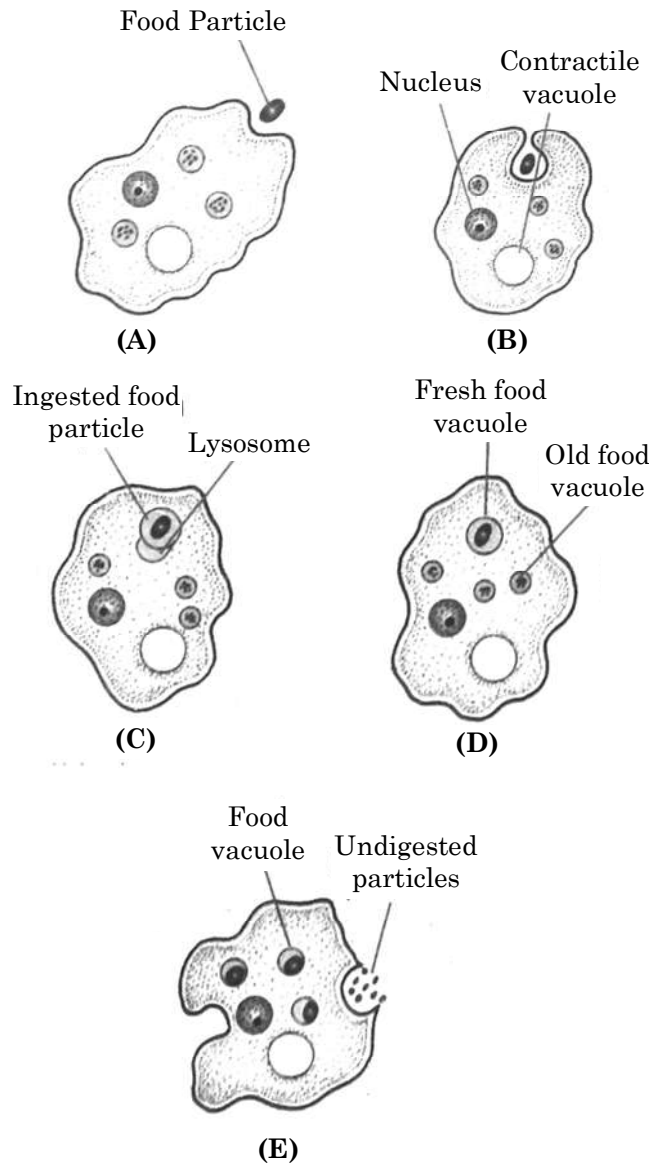

Figure : Holozoic Nutrition in Amoeba

- As soon as *Amoeba* comes in contact with a food particle or prey, it throws pseudopodia all around the same. The tips of encircling pseudopodia fuse and the prey comes to lie in a vesicle or **phagosome**.

Digestive System of Human

Digestive system is a group of organs & associated digestive glands that take part in ingestion, digestive absorption of food & egestion of undigested matter. Digestive organs form a continuous canal called alimentary canal. Alimentary Canal in man is 9 metres long & consists of the following parts.

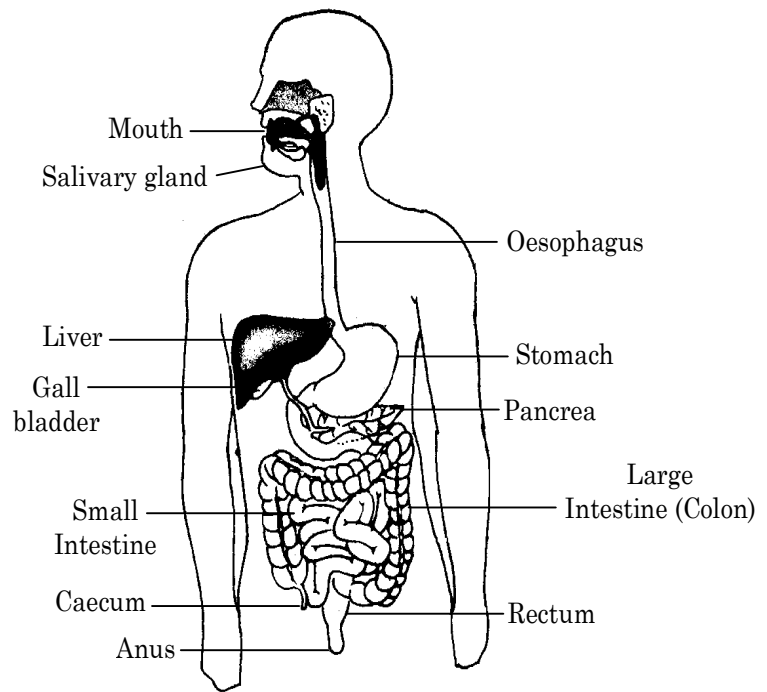
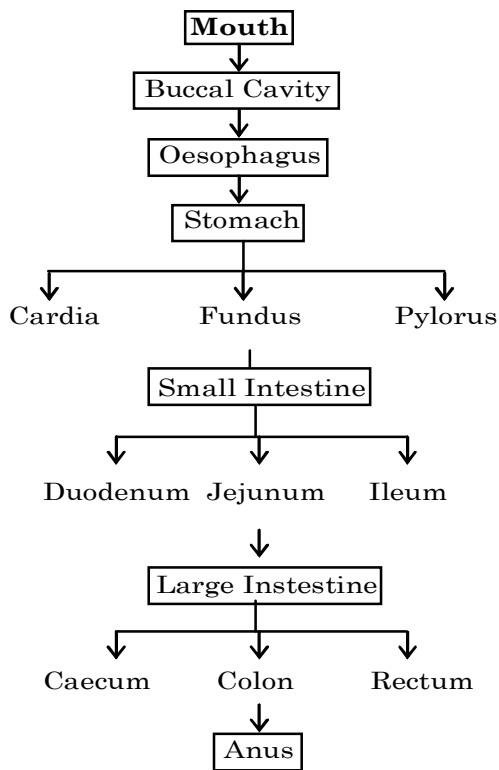

Figure : Digestive System

Ex.5 Why is digestion in Amoeba said to be intracellular ?

Ans. Intracellular means within a cell. Amoeba is a single-celled animals. All the life activities have to be performed within a single cell. Amoeba engulfs its food from the surrounding environment. Digestion, absorption, and assimilation occur inside the cell, hence it is said to exhibit intracellular mode of digestion.

◆ **Associated Glands :**

- (A) Salivary glands (B) Gastric glands (C) Liver (D) Pancreas

COMPETITIVE LEVEL

- Salivary glands are of three types :
 - (i) Parotid gland
 - (ii) Sub mandibular glands,
 - (iii) Sub lingual glands
- Gastric glands are of three types :
 - (i) Cardiac gland
 - (ii) Pyloric gland
 - (iii) Fundic gland
- Liver is a bilobed structure and is the largest gland present in the human body.
- Liver is the only organ that possess capacity to regenerate in human.

◆ **Mouth :**

Transverse slit like aperture which is bounded by lips.

◆ **Oral Cavity :**

It has teeth, tongue & palate.

(A) Teeth :

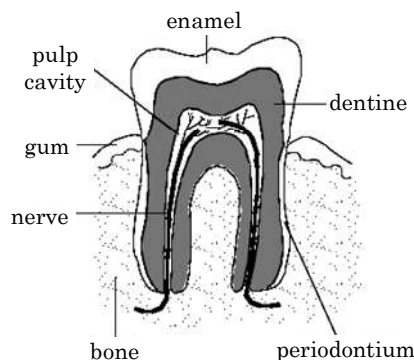

Figure : Tooth

- The food taken inside oral cavity is masticated i.e. mechanically broken into smaller particles before being swallowed by the help of teeth.
- Man possesses teeth on both the jaws, there are 32 teeth of four different types, namely incisors, canines, premolars & molars.
- There are four different types of teeth in humans (Heterodont).

Incisors	:	For cutting
Canines	:	For tearing
Premolars	:	For grinding
Molars	:	For grinding

◆ **Dental Caries :**

Dental caries or tooth decay causes gradual softening of enamel and dentine. It begins when bacteria acting on sugars produce acids that soften or demineralise the enamel. Masses of bacterial cells together with food particles stick to the teeth to form dental plaque. Saliva cannot reach the tooth surface to neutralize the acids as plaque covers the teeth. Brushing the teeth regularly removes the plaque before the bacteria produce acids. If untreated, microorganisms may invade the pulp, causing inflammation and infection.

Note : Brushing teeth properly avoids this situation.

COMPETITIVE LEVEL

◆ **Dental Formula :**

- (i) Milk teeth / Primary
- (ii) Permanent teeth

$$\frac{\text{No. of teeth in half part of upper jaw}}{\text{No. of teeth in half part of lower jaw}} \times 2 = x$$

- In Child $\rightarrow I \frac{2}{2}, C \frac{1}{1}, Pm \frac{0}{0}, M \frac{2}{2} = \frac{5}{5} \times 2 =$ Total 20 teeth
- In Man $\rightarrow I \frac{2}{2}, C \frac{1}{1}, Pm \frac{2}{2}, M \frac{3}{3} = \frac{8}{8} \times 2 =$ Total 32 teeth
- Jaws present in buccal cavity of humans are provided with four different types of teeth this is called **Heterodont**.
- Thecodont means “Socket tooth”, means that thecodont teeth are set in sockets of jaw bones.
- **Dental plaque** is a biofilm or mass of bacteria that grows on surfaces within the mouth.
- **Diastema** : It is a space or gap between two teeth.
- **Enamel** : It is the hardest substance of human body. It covers the crown portion of the tooth.
- **Dentin** : It is the hard dense bony tissue forming bulk of teeth & it is second hardest tissue in body after enamel.
- **Periodontium** : It refers to the specialized tissues that surround & support the teeth, maintaining them in their respective bones.

(B) Tongue

- The fleshy muscular organ in the mouth of a mammal, used for tasting, licking, swallowing and (in humans) articulating speech.
- It forms the floor of the mouth and bears taste buds.

◆ Pharynx :

- It is short conical region that lies after the oral cavity.
- It is a common passage to air and food.

◆ Oesophagus :

- It is a long narrow muscular tube which leads to the stomach. No digestive gland are present.
- It is also called as gullet or food pipe.
- **Peristalsis** is a series of contraction and relaxation of muscles of alimentary canal that pushes the food downward.

COMPETITIVE LEVEL

- Cooked starch $\xrightarrow[\text{Ptyalin}]{\text{Amylase}}$ Maltose
- Reverse peristalsis or retroperistalsis is the reverse of peristalsis, usually occur before vomiting.

◆ Stomach :

- It lies below the diaphragm on the left side of abdominal cavity.
- It is J-shaped. Its muscular walls help in mixing of food with the juices it produces.
- The entry is exist of food to and from the stomach is regulated by sphinter muscles
- Food is churned in the stomach for about three hours.
- HCl provides acidic medium to the food, and kill microorganisms present in the food.

- Mucus secreted by the stomach wall protects its wall from its own secretion of HCl.
- Peptic ulcers are sores or ulcers in the lining of the stomach, lower oesophagus, or small intestine, usually as a result of inflammation caused by the bacteria.
- Salivary amylase become inactive in stomach due to acidic pH.
- Pepsinogen $\xrightarrow{\text{HCl}}$ Pepsin
- Protein $\xrightarrow{\text{Pepsin}}$ Proteases
- Gastric lipases partially digest fats
- Prorenin $\xrightarrow{\text{HCl}}$ Rennin
- Casein $\xrightarrow{\text{Rennin}}$ Paracasein

◆ Small Intestine :

- It is a highly convoluted tube, and the site of complete digestion of food.
- Last part of small intestine is folded to form villi, which absorbs the products of digestion
- It receives three kind of juices :
 - (A) Pancreatic juice from pancreas
 - (B) Bile juice from liver
 - (C) Intestinal juice from the walls of intestine

- Liver secretes “Bile” which provides alkaline medium and emulsifies the fat molecules.
- Duodenal wall secretes enterokinase which activates the trypsin

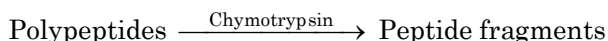
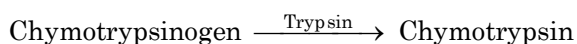
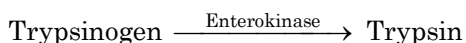

- Carbohydrates are converted to disaccharides by pancreatic amylase and maltase converts them to glucose.
- Pancreatic lipase converts emulsified fats to fatty acids and glycerols.
- Fats $\xrightarrow[\text{Emulsify}]{\text{Bile}}$ Fat globules $\xrightarrow{\text{Lipase}}$ Glycerol + Fatty acid
- It is the longest in herbivores and smallest in carnivores as cellulose has to be digested in herbivores.

Ex.6 What is the function of digestive enzymes ?

Ans. The major constituents of the diet are relatively complex, such as carbohydrate, protein, (at, etc. which cannot be absorbed unless they are broken down into simple compounds. The function of digestive enzymes is to help in breaking down of complex food materials into simpler compounds which can be readily used by animals through absorption and assimilation. As such, digestive enzymes help in converting proteins into amino acids, fats into fatty acids, and glycerols and polysaccharides into monosaccharides.

Ex.7 Write any two regions of alimentary canal in which no digestion occur?

Ans. Oesophagus, Large intestine.

Ex.8 What is the importance of Sphincters?

Ans. It regulates the exit of food in small amounts.

Ex.9 What is the role of saliva in the digestion of food?

Ans. Saliva contains salivary amylase and is released in our mouth. It breaks down starch into sugar (complex carbohydrates into simpler ones).

Ex.10 Why do herbivores have longer small intestine where as carnivores have shorter small intestine ?

Ans. Herbivores eat grass which has maximum cellulose content. It needs greater time for digestion. Carnivores eat meat which is easier to digest. Therefore, herbivores need longer small intestine and carnivores need shorter small intestine.

COMPETITIVE LEVEL

- The duodenum part of small intestine receives secretions from Liver and Pancreas through a common duct called the "Hepato-Pancreatic Duct".
- Differentiated into 3 regions, viz. **Duodenum** which is the first part of small intestine & is curved C-shaped; **Jejunum**, comparatively longer & more coiled and **Ileum**,

◆ Large Intestine :

- It is much shorter & wider than small intestine
- No digestion takes place in large intestine, only absorption of water takes place.
- In herbivores like horse, rabbit digestion of cellulose takes place in caecum.

◆ Absorption :

- Some simple sugars are absorbed in the mouth.
- In the small intestine (ileum) absorption of all digested materials takes place through villi.
- Excess water is absorbed by the large intestine.

◆ Assimilation :

- It is the process of utilisation of absorbed food for various body functions. The absorbed nutrients are utilised to synthesise complex molecules like carbohydrates, protein & fats inside the cells.
- Man cannot digest cellulose due to the appendix being vestigial.

◆ Egestion :

- It is the process of elimination of undigested food formed in the cells, or in the lumen of large intestine (colon & rectum) through the anus.
- Voluntary contraction of abdominal muscles help in egestion of faeces. Anal sphincter guards the exit of waste material from Anus.

COMPETITIVE LEVEL

- Large intestine is differentiated into three regions;
- **Caecum** which is small rounded blind sac from which vermiform appendix arises.
- **Colon** is the inverted U-shaped tube.
- The **rectum** opens to exterior through anus.

◆ **Summary of digestion enzymes of various glands with their secretions and end products of Digestion in Man :**

TABLE : DIGESTIVE GLANDS, THEIR SECRETIONS & ACTION

Name of Gland	Secretion	Enzyme	Site of action	Substrates	Products
Salivary glands	Saliva	Salivary Amylase	Buccal cavity	Starch	Maltose., Isomaltose
Gastric glands	Gastric Juice	(a) Pepsin (Pepsinogen inactive)	Stomach	Protein	Peptones
		(b) Rennin (Prorennin inactive)	Stomach	Casein	Paracasein
Pancreas	Pancreatic Juice	(a) Pancreatic Amylase	Small intestine	Starch Glycogen	Maltose, Isomaltose
		(b) Trypsin (Trypsinogen inactive)	Small intestine	Proteins	Peptides
		(c) Chymotrypsin (Chymotrypsinogen inactive)	Small intestine	Casein (milk)	Paracasein
Intestinal gland (Crypts of Lieberkuhn)	Intestinal Juice	(a) Enterokinase (Hormone)	Small intestine	Trypsinogen (inactive)	Trypsin (active)
		(b) Aminopeptidase	Small intestine	Peptides	Smaller peptides Amino acids
		(c) Dipeptidases	Small intestine	Dipeptides	Amino acids
		(d) Isomaltase	Small intestine	Isomaltose	2 Glucose
		(e) Maltase	Small intestine	Maltose	2 Glucose
		(f) Sucrase	Small intestine	Sucrose	Glucose, Fructose
		(g) Lactase	Small intestine	Lactose	Glucose, Galactose
		(h) Lipase	Small intestine	Triglycerides	Monoglycerides, Fatty acids
Liver	Bile (Bile + pigments)	No enzymes	Duodenum	Fats	Fat droplets

EXERCISE-1

➤ Very Short Answer Type Questions

- Q.1 Define villi.
- Q.2 What are heterotrophs ?
- Q.3 Which types of organisms are called consumers ?
- Q.4 What is the role of oesophagus ?
- Q.5 Define saprophyte.
- Q.6 What are the functions of liver in humans ?
- Q.7 Which type of animal is called omnivore?
- Q.8 Define digestion.
- Q.9 What is ingestion?
- Q.10 What is dental plaque?

➤ Short Answer Type Questions – Type I

- Q.11 What type of digestion occurs in *Paramecium*?
- Q.12 How do saprophytic organisms obtain their nourishment?
- Q.13 Why chlorophyll is needed for photosynthesis?
- Q.14 Name a digestive juice that has no enzymes. What is the role of this juice?
- Q.15 Name the various parts of large intestine. What is the role of large intestine?

➤ Short Answer Type Questions – Type II

- Q.16 How does nutrition occur in *Amoeba*?
- Q.17 Differentiate between autotrophic and heterotrophic nutrition.
- Q.18 Distinguish saprophytes from parasites.
- Q.19 Differentiate between photosynthetic and holozoic nutrition.
- Q.20 What is the action of hydrochloric acid of gastric juice ?

➤ Long Answer Type Questions

- Q.21 Explain the mechanism of photosynthesis.
- Q.22 Describe the various types of heterotrophic nutrition.
- Q.23 Briefly describe the digestive system of humans.
- Q.24 What happens to food in the small intestine ?
- Q.25 What is the physical digestion of food ? Where does it occur ? What is its importance ?

➤ Practical & Value Based Type Questions

- Q.26 Om, Rohit and Kishore always remain in a hurry. One day, during lunch hour they all quickly gulped food and went out to play. (i). Om suddenly developed stomach ache while playing. What according to you might have gone wrong with him.
- Q.27 One day Mohan had a severe toothache. His father took Mohan to a dentist. The dentist examined all the teeth of Mohan very carefully and said that he had tiny holes in his two teeth. He also told Mohan that all his teeth were covered with a sticky, yellowish layer. The dentist performed a certain procedure on his two teeth having tiny holes and also gave him some medicines. Mohan's toothache disappeared gradually.
- (a) What are the tiny holes in the teeth known as ?
- (b) How are the tiny holes formed in the teeth ?
- (c) What kind of procedure was performed by dentist on Mohan's two teeth ?
- (d) What is the sticky, yellowish layer on Mohan's teeth known as ?
- (e) How is the sticky, yellowish layer formed on the teeth ?
- (f) What advice will you give to Mohan to avoid such dental problems in future ?

Q.28 One day Mohan had a severe toothache. His father took Mohan to a dentist. The dentist examined all the teeth of Mohan very carefully and said that he had tiny holes in his two teeth. He also told Mohan that all his teeth were covered with a sticky, yellowish layer. The dentist performed a certain procedure on his two teeth having tiny holes and also gave him some medicines. Mohan's toothache disappeared gradually.

- What are the tiny holes in the teeth known as ?
- How are the tiny holes formed in the teeth ?
- What kind of procedure was performed by dentist on Mohan's two teeth ?
- What is the sticky, yellowish layer on Mohan's teeth known as ?
- How is the sticky, yellowish layer formed on the teeth ?
- What advice will you give to Mohan to avoid such dental problems in future ?

Q.29 A round black paper with star-shaped hole was used to cover a leaf in a destarched plant as shown below. The plant was left in sunlight for four hours and then the leaf was plucked, black paper removed and tested for the presence of starch. Which areas will turned blue-black ?

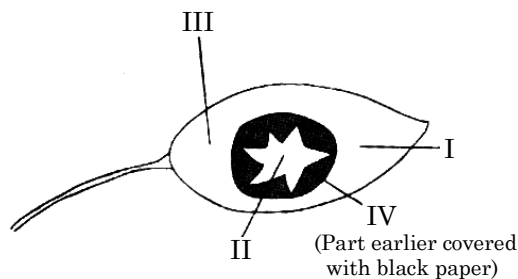

Q.30 In the following sketch of the stomatal apparatus, labeled the following parts.

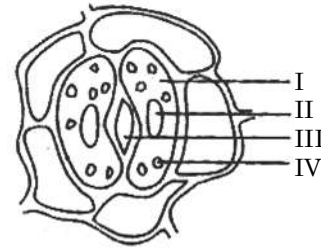

EXERCISE-2

- Q.1** CO₂ and O₂ balance in atmosphere is due to
(A) Photorespiration
(B) Photosynthesis
(C) Respiration
(D) Transpiration
- Q.2** During photosynthesis the oxygen in glucose comes from
(A) Water
(B) Carbon dioxide
(C) Both from water and carbon dioxide
(D) Oxygen in air
- Q.3** First stable compound in C₃ cycle is
(A) Phosphoglyceraldehyde
(B) Phosphoglyceric acid
(C) Fructose-1-6 diphosphate
(D) Glucose-6-phosphate
- Q.4** Dark reaction of photosynthesis occurs in the
(A) Stroma of the chloroplast outside the lamellae
(B) Space between the two membranes of the chloroplast
(C) Membranes of the stroma lamellae
(D) Thylakoid membrane of the grana
- Q.5** A specific function of light energy in the process of photosynthesis is to
(A) Activate chlorophyll
(B) Oxidation of CO₂
(C) Synthesis of glucose
(D) Reduce CO₂
- Q.6** Digestion within a digestive tract is
(A) Incomplete
(B) Extracellular
(C) The same as absorption
(D) A reversible process
- Q.7** Dark reaction in photosynthesis is called so because
(A) It does not require light energy
(B) Cannot occur during daytime
(C) Occurs more rapidly at night
(D) It can also occur in darkness
- Q.8** Phloem always flows from a
(A) Solar source to sugar sink
(B) Sugar sink to sugar source
(C) Leaf to the xylem to the phloem
(D) Leaf to a root
- Q.9** With regards to natural eating habits, a human is
(A) An herbivore (B) A carnivore
(C) An omnivore (D) A Granivore
- Q.10** Muscular contractions of alimentary canal are
(A) Circulation (B) Deglutition
(C) Peristalsis (D) Churning
- Q.11** Which of the following regions of the alimentary canal of man does not secrete a digestive enzyme?
(A) Oesophagus (B) Stomach
(C) Duodenum (D) Mouth
- Q.12** A digestive enzyme, salivary amylase, in the saliva begin digestion of
(A) Protein (B) Nucleic acids
(C) Fats (D) Carbohydrates
- Q.13** If you chew on a piece of bread long enough, it will begin to taste sweet because
(A) Maltase is breaking down maltose
(B) Lipases are forming fatty acids
(C) Amylase is breaking down starches to disaccharides
(D) Disaccharides are forming glucose
- Q.14** In the presence of lactase, lactose breaks down into molecules of
(A) Glucose and galactose
(B) Glucose and fructose
(C) Galactose only
(D) Glucose only
- Q.15** Saliva has the enzyme
(A) Pepsin (B) Ptyalin
(C) Trypsin (D) Rennin

- Q.16** Pepsin digests
 (A) Proteins in stomach
 (B) Carbohydrates in duodenum
 (C) Proteins in duodenum
 (D) Fats in ileum
- Q.17** Curding of milk in the stomach is due to the action of
 (A) Lipase (B) Rennin
 (C) Ptyalin (D) Tannin
- Q.18** Chief function of HCl is
 (A) To maintain a low pH to prevent growth of micro-organisms
 (B) To facilitate absorption
 (C) To maintain low pH to activate pepsinogen to form pepsin
 (D) To dissolve enzyme secreted in stomach
- Q.19** If the stomach did not producing any hydrochloric acid, which enzyme will not function ?
 (A) Ptyalin
 (B) Trypsin
 (C) Pepsin
 (D) Collagenase
- Q.20** Chief function of bile is
 (A) To digest fat by enzymatic action
 (B) To emulsify fat for digestion
 (C) To eliminate waste product
 (D) To regulate process of digestion
- Q.21** Where is bile produced ?
 (A) In gall bladder
 (B) In blood
 (C) In liver
 (D) In spleen
- Q.22** Ileum is
 (A) First part of the small intestine
 (B) Middle part of the small intestine
 (C) Last part of the small intestine
 (D) Not a part of the small intestine
- Q.23** Largest gland in human body is
 (A) Liver
 (B) Pancreas
 (C) Pituitary
 (D) Thyroid
- Q.24** The specific function of liver is
 (A) Excretion
 (B) Digestion
 (C) Histolysis
 (D) Glycogenesis and glycogenolysis
- Q.25** The original function of the vertebrate stomach was
 (A) Storage
 (B) Digestion
 (C) Enzyme secretion
 (D) Absorption
- Q.26** What is bile ?
 (A) a type of cell
 (B) a type of tooth
 (C) a solution that helps to break down fats
 (D) a food droplet
- Q.27** What do proteins get broken down into ?
 (A) amino acids (B) glucose
 (C) starch (D) fatty acids
- Q.28** What are the conditions in the stomach ?
 (A) alkaline (B) neutral
 (C) cold (D) acidic
- Q.29** What do large insoluble molecules get broken down into ?
 (A) large soluble molecules
 (B) small soluble molecules
 (C) medium soluble molecules
 (D) small insoluble molecules
- Q.30** When does photosynthesis take place ?
 (A) during the day (B) at night
 (C) night and day (D) in the winter

EXERCISE-3

(Previous Year Questions - NTSE & NSO)

- Q.1** Bile Juice is secreted from -
(A) Salivary glands
(B) Intestinal glands
(C) Stomach
(D) Liver
- Q.2** When acidity in Stomach increases, the medicine generally used is -
(A) Sodium bicarbonate
(B) Sodium Carbonate
(C) Ammonium Carbonate
(D) Ammonium bicarbonate
- Q.3** Substances necessary for autotrophic Nutrition are -
(A) CO₂ and H₂O (B) Chlorophyll
(C) Sun light (D) All of the above
- Q.4** Consider following chemical reaction
 $6\text{CO}_2 + 2\text{H}_2\text{O} \longrightarrow \text{C}_6\text{H}_{12}\text{O}_6 + 6\text{O}_2 + 6\text{H}_2\text{O}$
(a) CO₂ is oxidized to glucose
(b) CO₂ is reduced to glucose
(c) H₂O is oxidized to O₂
(d) H₂O is reduced to O₂
Which answer is correct?
(A) a & d (B) b & c
(C) b & d (D) a & c
- Q.5** Covering of lungs is -
(A) Pleura (B) Pericardium
(C) Epiglottis (D) Capsule
- Q.6** Exchange of gasses occurs through
(A) Stomata
(B) Lenticles
(C) Root surfaces
(D) All of the above
- Q.7** Concentrated nitric acid is used in a test to detect adulteration of :
(A) Cooking oil
(B) Milk
(C) Salt
(D) Tea powder
- Q.8** In an experiment where two potted plants kept in a dark room are used to demonstrate that carbondioxide is essential for photosynthesis potassium hydroxide is used because it :
(A) Releases oxygen
(B) Absorbs carbondioxide
(C) Releases carbon dioxide
(D) Absorbs oxygen
- Q.9** Which one of the following enzymes is present in saliva ?
(A) Pepsin (B) Chymotrypsin
(C) Trypsin (D) Ptyalin
- Q.10** Which one of the following compound contains two carbon atoms ?
(A) Ethanol (B) Pyruvic acid
(C) Lactic acid (D) lucose
- Q.11** Read the following two statements and choose the correct answer.
i. Stomata regulates the body temperature in plants.
ii. Stomata helps in the absorption of minerals from the soil.
(A) i is true but ii is false
(B) i is false but ii is true
(C) Both i and ii are true
(D) Both i and ii are false
- Q.12** Which part of the human alimentary canal, is the site for complete digestion of carbohydrates.
(A) Stomach
(B) Small Intestine
(C) Large Intestine
(D) Rectum
- Q.13** This part of alimentary canal absorbs maximum amount of water and minerals:
(A) Small intestine
(B) Large intestine
(C) Stomach
(D) Oesophagus

- Q.14** Food becomes _____ due to bile juice.
 (A) Acidic
 (B) Alkaline
 (C) Neutral
 (D) First neutral and then acidic
- Q.15** Which of the following enzymes is related with digestion of protein ?
 (A) Lipase (B) Pepsin
 (C) Sucrase (D) Amylase
- Q.16** What does liver secrete ?
 (A) Insulin (B) Bile
 (C) Gastric juice (D) Mucus
- Q.17** Which of the following plant is a parasite ?
 (A) Cuscuta (B) Mushroom
 (C) Giloe (D) Fern
- Q.18** Which two plant species obtain nutrition as symbionts in Lichens ?
 (A) Rhizobium and Drosera
 (B) Fungi and Rose plant
 (C) Algae and Virus
 (D) Algae and Fungi
- Q.19** Assertion : Photosynthesis is minimum in green light
 Reason : Chlorophylls are green in colour.
 Direction :
 (A) Both assertion and reason are true and reason is correct explanation of assertion.
 (B) Both assertion and reason are true but reason is not correct explanation of assertion
 (C) Assertion is true but reason is False
 (D) Assertion is false but reason is true.
- Q.20** The substance essential for photosynthesis is
 (A) glucose (B) oxygen
 (C) nitrogen (D) water
- Q.21** Chlorophyll contains.....
 (A) Potassium (B) Iron
 (C) Manganese (D) Magnesium
- Q.22** Which of the following is an example of Insectivorous plant -
 (A) Cuscuta (B) Rafflesia
 (C) Drosera (D) Tulsi
- Q.23** Photosynthesis is an important mode of autotrophic nutrition. The event which does not occur in photosynthesis is :
 (A) Conversion of light energy to chemical energy
 (B) Reduction of carbon dioxide to carbohydrate
 (C) Oxidation of carbon to carbon dioxide
 (D) Absorption of light energy by chlorophyll
- Q.24** Which is the longest organ of the digestive system ?
 (A) Oesophagus (B) Stomach
 (C) Small Intestine (D) Large Intestine
- Q.25** Deficiency of vitamin 'A' causes –
 (A) Beri-Beri (B) Anaemia
 (C) Night blindness (D) Scurvy
- Q.26** One of the following juices secreted in the body of man does not contain any enzyme –
 (A) Gastric juice (B) Saliva
 (C) Bile juice (D) Pancreatic juice
- Q.27** Which of the following factors does a plant use for the process of photosynthesis ?
 (A) Sunlight (B) Chlorophyll
 (C) CO₂ and H₂O (D) All of them
- Q.28** The substance not essential for photosynthesis is
 (A) sunlight (B) chlorophyll
 (C) nitrogen (D) carbon dioxide.
- Q.29** The small intestine receives the secretion from
 (A) Salivary glands
 (B) Stomach and liver
 (C) Liver and salivary glands
 (D) Liver and Pancreas

ANSWER KEY

EXERCISE - 2

Ques.	1	2	3	4	5	6	7	8	9	10	11	12	13	14	15
Ans.	B	B	B	A	A	B	A	A	C	C	A	D	C	A	B
Ques.	16	17	18	19	20	21	22	23	24	25	26	27	28	29	30
Ans.	A	B	C	C	B	C	C	A	D	A	C	A	D	B	A

EXERCISE - 3

Ques.	1	2	3	4	5	6	7	8	9	10	11	12	13	14	15
Ans.	D	A	D	B	A	D	B	B	D	A	A	B	B	B	B
Ques.	16	17	18	19	20	21	22	23	24	25	26	27	28	29	
Ans.	B	A	D	A	D	D	C	C	C	C	C	D	A	D	

SOLUTIONS

EXERCISE-1

➤ Very Short Answer Type Questions

- Sol.1** Villi : Finger like projection that help in the increasing surface area for absorption. They are present in small intestine
- Sol.2** Heterotroph are the organism that cannot synthesized their own food. They are dependent on producer
Ex. Human, cow
- Sol.3** Organism that get their energy from producer by consuming them
Ex. Cat, cow, buffalo
- Sol.4** Oesophagus is a connection between buccal cavity to stomach
- Sol.5** Saprophyte are organism that depend on dead decaying matter for their nutrition.
- Sol.6** Function of liver in human
(I) Detoxification
(II) Urea formation
(III) Helps in Fat digestion by emulsifying them.
- Sol.7** Omnivore : Organism that obtained their energy from plants & meat of animals
Ex. Crow, Human
- Sol.8** Digestion : Breakdown of nutritive material from its complex to simple form
Ex. Protein → Amino acid
- Sol.9** Ingestion : intake of food through buccal cavity
- Sol.10** Dental plaque is a biofilm or mass of bacteria that grows on surfaces within the mouth.

➤ Short Answer Type Questions – Type I

- Sol.11** Endocytosis : Paramoecium gathered its food with the help of water flow and food goes into oral cavity by the opening of gullet and then food enter into vacuole and after digestion food goes into cytoplasm the its used for metabolic activity
- Sol.12** Saprophytic organism obtained their nourishment and food from dead decaying matter with the. help of breakdown of complex structure into simpler form by secreting digestive juices.
- Sol.13** Chlorophyll is needed for photosynthesis because chlorophyll have energy harvesting complex that eject electron for synthesis of glucose by absorption of sunlight.
- Sol.14** Bile juice does not contain any enzyme its only have bile salts and bile pigments that help in breakdown of large fat globule into smaller globule .It also makes the medium alkaline.
- Sol.15** Large intestine
I Caecum
II Colon
III Rectum
(I) Main function of large intestine is water absorption
(II) Formation of faecal matter
- Sol.16** Amoeba show phagocytosis process for digestion .First amoeba ingest food with the help of pseudopodia and then food enter into vacuole, and after digestion its come out into cytoplasm for metabolic activity and undigested food is removed out of body.
- Sol.17** Autotrophic nutrition : It is mode of nutrition in which organism can synthesize their food with the help of light /chemical are known as autotrophic nutrition.

Ex. Plants, Bacteria, (Cyanobacteria)
 Heterotrophic nutrition :It is mode of nutrition in which Organism depend on producer for food are known as heterotrophic nutrition .They cannot synthesis their own food
Ex. Animal, Fungi, Heterotrophic bacteria

Sol.18 Saprophytes : In this type of nutrition organism depend upon dead decaying matter and obtained their energy and complete their metabolic activity
Ex. Mushroom(Fungi).
 Parasites that type of organism that are dependent on another organism and obtained their energy from that organism
Ex.Ticks, mites

Sol.19

Photosynthetic Nutrition	Holozoic Nutrition
1. Autotrophic nutrition 2. Pigment required for energy synthesis 3. They are producer in trophic levels EX. Plants (Mainly)	(i) Heterotrophic nutrition (ii) obtained energy from solid materials (iii) These are consumers in trophic levels EX. Animals, (Human)

Sol.20 HCL activates the enzyme like

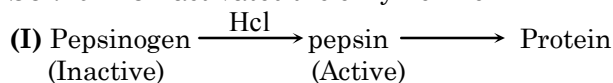

(II) Its kill germs in food

➤ Long Answer Type Questions

Sol.21 Mechanism of photosynthesis
 Photosynthesis : The process by which green plants synthesise food from simple substances i.e,CO₂ and water in the presence of light and chlorophyll.
 Two reaction –:
 (i) Light reaction
 (ii) Dark reaction
 (i) Light reaction :-
 This reaction is completed in the presence of light and this process occur in thylakoid
 (ii) Dark reaction :-
 This reaction not dependent on light but dependant on the product of light reaction (ATP & NA DPH₂)
 Reaction occur in stroma.

Sol.22 Heterotrophic nutrition :-
 That type of nutrition in which organism dependent on another organism

Ex. Human, Amoeba, Paramoecium
 (i) Saprophytic nutrition –It is the mode of nutrition in which organism depend on dead decay matter for their nutrition.
 (ii) Parasitic nutrition –It is the mode of nutrition in which organism obtain energy from another organism
Ex. Ticks, Mites, Cuscutta
 (iii) Holozoic nutrition -: It is the mode of nutrition in which

Organism ingest raw material in solid form

(A) Herbivore :-
 Organism that feeds on herbs & shrubs (plant)

Ex. Deer, Cow
 (B) Carnivores :-
 Organism that feeds on the flesh of animals are known as carnivores.

Ex. lion, tiger
 (C) Omnivores Organism that feeds on both plants and animals **Ex.** man, bear

Sol.23 Human digestion system consists of

Alimentary canal	Associated gland
1. Buccal Cavity	1. Salivary gland
2. Oesophagus	2. Pancreases
3. Stomach	3. Liver
4. Small intestine	
5. Large intestine	
6. Anus	

Mouth – It has buccal cavity. It has teeth, tongue and palate. Teeth helps in chewing of food. Tongue helps in mixing of saliva with food. It also has salivary glands that produces saliva. Salivary amylase present in saliva helps in breaking down of carbohydrates (starch into maltose)

2. Pharynx – It is a common passage to air and food
3. Oesophagus – It helps in pushing food to stomach by peristaltic movement.
4. Stomach – It is a bag like structure. It produces gastric juices. Gastric juices contain HCL, mucus and enzyme pepsinogen. Digestion of proteins starts here.

5. Small intestine – It is differentiated into 3 regions viz. Duodenum, Jejunum and Ileum, Duodenum receives secretions from liver and pancreas. Complete digestion of food takes place. Absorption of nutrients also takes place.
6. Large intestine – It has 3 regions caecum, colon and rectum. Water absorption takes place.
7. Anus – Egestion takes place through anus

Sol.24 Small Intestine

- (i) It is a highly convoluted tube and the site of complete digestion of food.
- (ii) Last part of small intestine is folded to form villi, which absorb the products of digestion
- (iii) It receives three kind of juices
(A) Pancreatic juice from pancreas
(B) Bile juice from liver
(C) Intestinal juice from the walls of intestine
- (iv) Liver secretes “Bile” which provides alkaline medium and emulsifies the fat molecules.
- (v) Duodenal wall secretes enterokinase which activates the trypsin

Trypsinogen $\xrightarrow{\text{Enterokinase}}$ Trypsin

Chymotrypsinogen $\xrightarrow{\text{Trypsin}}$ Chymotrypsin

Polypeptides $\xrightarrow{\text{Chymotrypsin}}$ Peptide fragments

Finally proteins get digested into amino acid

- (vi) Carbohydrates are converted to disaccharides by pancreatic amylase and maltase converts them to glucose.
- (vii) Pancreatic lipase converts emulsified fats to fatty acids and glycerols.
- (viii) Fats $\xrightarrow[\text{Emulsify}]{\text{Bile}}$ Fat globules
 $\xrightarrow{\text{Lipase}}$ Glycerol + Fatty acid

Sol.25 Physical Digestion :

Physical digestion starts in buccal cavity. In this part food is divided into small pieces and forms a ball-like structure \Rightarrow Bolus.

- This process occurs in buccal cavity

Importance :

- Food is divided into small pieces - Bolus
- Mixing of Saliva and mastication of food
- For the movement of food from buccal cavity to stomach.

Practical & Value Based Type Questions

Sol.26 Ex. Practical value based type question :

Om developed stomachache as he had not chewed his food properly. Large food pieces if enter the stomach might cause damage.

Sol.27

- Ex.**(a) Tiny holes formed in the teeth are known as cavities.
- (b) When a person eats sugary food, then the bacteria produce acids. These acids first dissolve the calcium salts from tooth enamel and then from dentine forming tiny holes in the tooth over a period of time.
 - (c) Mohan's dental cavities were first cleaned by the dentist. and then filled with appropriate filling material.
 - (d) The sticky, yellowish layer on the teeth is known as dental plaque.
 - (e) If the teeth not cleaned regularly, they become covered with a sticky, yellowish layer of food particles and bacteria cells called dental plaque
 - (f) (i) Mohan should eat less of sugary food such as toffees, chocolates etc.
(ii) Mohan should brush his teeth regularly with a toothpaste
(iii) Mohan should get his teeth examined by a dentist at least once in three months.

Sol.28

- Ex.**(a) Tiny holes formed in the teeth are known as cavities.
- (b) When a person eats sugary food, then the bacteria produce acids. These acids first dissolve the calcium salts from tooth enamel and then from dentine forming tiny holes in the tooth over a period of time.
 - (c) Mohan's dental cavities were first cleaned by the dentist. and then filled with appropriate filling material.

- (d) The sticky, yellowish layer on the teeth is known as dental plaque.
- (e) If the teeth not cleaned regularly, they become covered with a sticky, yellowish layer of food particles and bacteria cells called dental plaque
- (f) (i) Mohan should eat less of sugary food such as toffees , chocolates etc.
- (ii) Mohan should brush his teeth regularly with a toothpaste
- (iii) Mohan should get his teeth examined by a dentist at least once in three months.

Sol.29 Area that are covered with black Paper show negative result and uncovered area show positive results.
Positive – I, II, III-will show blue black color.
Negative – IV-will not show blue black color.

- Sol.30** 1. Guard Cell
2. Nucleus
3. Stomatal Aperture
4. chloroplast

EXERCISE-2

- Sol.1 [B]**
CO₂ is utilized to make glucose and O₂ is released during the process.
- Sol.2 [B]**
O₂ in glucose come from CO₂
- Sol.3 [B]**
CO₂ combines with RUBP to form first stable compound phosphoglyceric acid.
- Sol.4 [A]**
Dark reaction takes place in Stroma of the chloroplast.
- Sol.5 [A]**
Activation of chlorophyll for e⁻ ejection.
- Sol.6 [B]**
Food digestion takes place outside the Cells.

Sol.7 [A]
Dark reaction doesn't require light but it is dependent on light reaction products (ATP & NADPH₂)

Sol.8 [A]
Source \longrightarrow Sink
(Stem, root, leaf)

Sol.9 [C]
Omnivore eats both plants and meat of animals.

Sol.10 [C]
Muscular contraction – Peristalsis is a series of contraction and relaxation of muscles of alimentary canal that pushes the food.

Sol.11 [A]
Oesophagus – Its a connection between Buccal cavity to stomach.
No digestion takes place.

Sol.12 [D]
Salivary amylase \rightarrow Carbohydrate to maltose

Sol.13 [C]
Starch $\xrightarrow{\text{amylase}}$ Disaccharide (maltose)

Sol.14 [A]
Lactose $\xrightarrow{\text{lactase}}$ Glucose + Galactose

Sol.15 [B]
Ptyalin – Help in breakdown of carbohydrate.

Sol.16 [A]
Pepsin digest protein in stomach because it's a proteolytic enzyme.

Sol.17 [B]
Casein $\xrightarrow{\text{Renin}}$ paracasein

Sol.18 [C]
HCl activate inactive enzyme
Pepsinogen $\xrightarrow{\text{HCl}}$ Pepsin
Prorenin $\xrightarrow{\text{HCl}}$ Rennin

Sol.19 [C]
Because pepsin gets activated at low pH.

Sol.20 [B]
Bile synthesised into liver helps in fat emulsification.

Sol.21 [C]
Bile is produced by Liver

Sol.22 [C]
Last part of small intestine is ileum.

Sol.23 [A]
Largest gland is Liver

Sol.24 [D]
Function of liver
Glucose $\xrightarrow{\text{Glycogenesis}}$ Glycogen
Glycogen $\xrightarrow{\text{Glycogenolysis}}$ Glucose

Sol.25 [A]
Storage of food was the original function of the vertebrate stomach

Sol.26 [C]
Help in emulsification of fat.

Sol.27 [A]
Protein \longrightarrow Amino acid

Sol.28 [D]
Acidic due to HCL

Sol.29 [B]
Large molecules \rightarrow Small molecules

Sol.30 [A]
During day time.

EXERCISE-3

Sol.1 [D]
Bile juice secreted by liver help in emulsification of fat.

Sol.2 [A]
When acidity in stomach increase medicine generally used is sodium bicarbonate (NaHCO_3) for neutralising inner environment.

Sol.3 [D]
For Autotrophic nutrition essential substance needed are

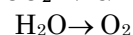
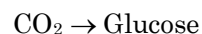

in the presence of chlorophyll and sunlight.

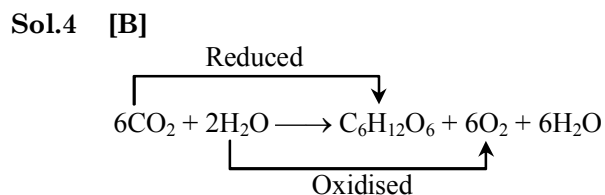

Sol.5 [A]
Covering of lungs is pleura.

Sol.6 [D]
Exchange of gases through
Stomata – leafs
Lenticles – Stem
Root Surface – Root

Sol.7 [B]
Concentrated nitric acid is used in test to detect adulteration of milk

Sol.8 [B]
KOH absorbs CO_2

Sol.9 [D]
Saliva contain ptyalin
Carbohydrate $\xrightarrow{\text{Ptyalin}}$ Disaccharide

Sol.10 [A]
Ethanol is two carbon compound

Sol.11 [A]
Stomata help for cooling body temperature in plants

Sol.12 [B]
Carbohydrate digestion start from buccal cavity and end in small intestine

Sol.13 [B]
Large intestine absorb water & minerals.

Sol.14 [B]
Food become alkaline due to bile juice for fat emulsification.

Sol.15 [B]
Proteolytic enzyme → Pepsin in (stomach)
Pepsin helps in digestion of proteins.

Sol.16 [B]
Liver secrete bile.

Sol.17 [A]
Parasitic plant cuscutta obtain food from another living organism.

Sol.18 [D]
Algae & fungi
Algae for food synthesis and fungi for shelter.

Sol.19 [A]
– Photosynthesis is minimum in green light because its only reflected by chlorophyll.
– Chlorophyll are green in color

Sol.20 [D]
Water is essential for photosynthesis

Sol.21 [D]
Chlorophyll contain magnesium in center

Sol.22 [C]
Insectivorous plant – Drosera Complete N₂ deficiency by eating insects.

Sol.23 [C]
Because oxidation takes place in H₂O

Sol.24 [C]
Longest organ small intestine approx 6 mts.

Sol.25 [C]
Deficiency of vitamin A causes night blindness.

Sol.26 [C]
Bile juice not contain enzyme
Helps in emulsification of fat.

Sol.27 [D]
$$6\text{CO}_2 + 12\text{H}_2\text{O} \xrightarrow[\text{Chlorophyll}]{\text{Light}} \text{C}_6\text{H}_{12}\text{O}_6 + 6\text{O}_2 + 6\text{H}_2\text{O}$$

Sol.28 [C]
Nitrogen not essential for photosynthesis.

Sol.29 [D]
Small intestine receive from Liver & Pancreas. Bile juice and pancreatic juice is received a common duct called hepatopancreatic duct.

NOTES

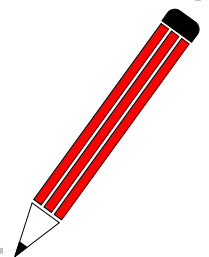

MATHEMATICS

REAL NUMBERS

Chapter Outline

- ✦ Number System
- ✦ Euclid's Division Lemma
- ✦ Euclid's Division Algorithm
- ✦ The Fundamental Theorem of Arithmetic
- ✦ Number of Factors
- ✦ HCF and LCM
- ✦ Logarithm
- ✦ Highest Power dividing Factorial

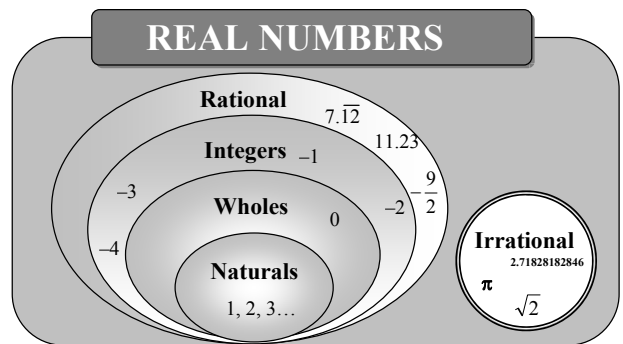

The Real Number Line

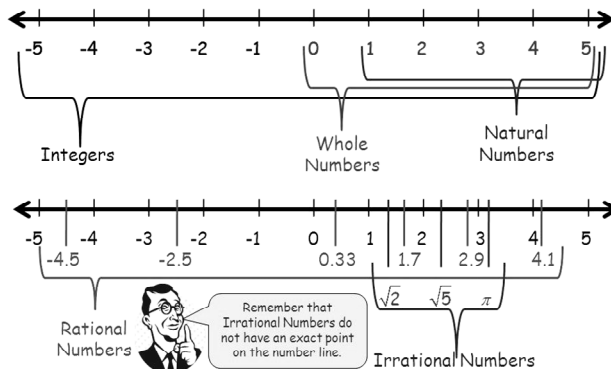

MIND MAP

REAL NUMBERS

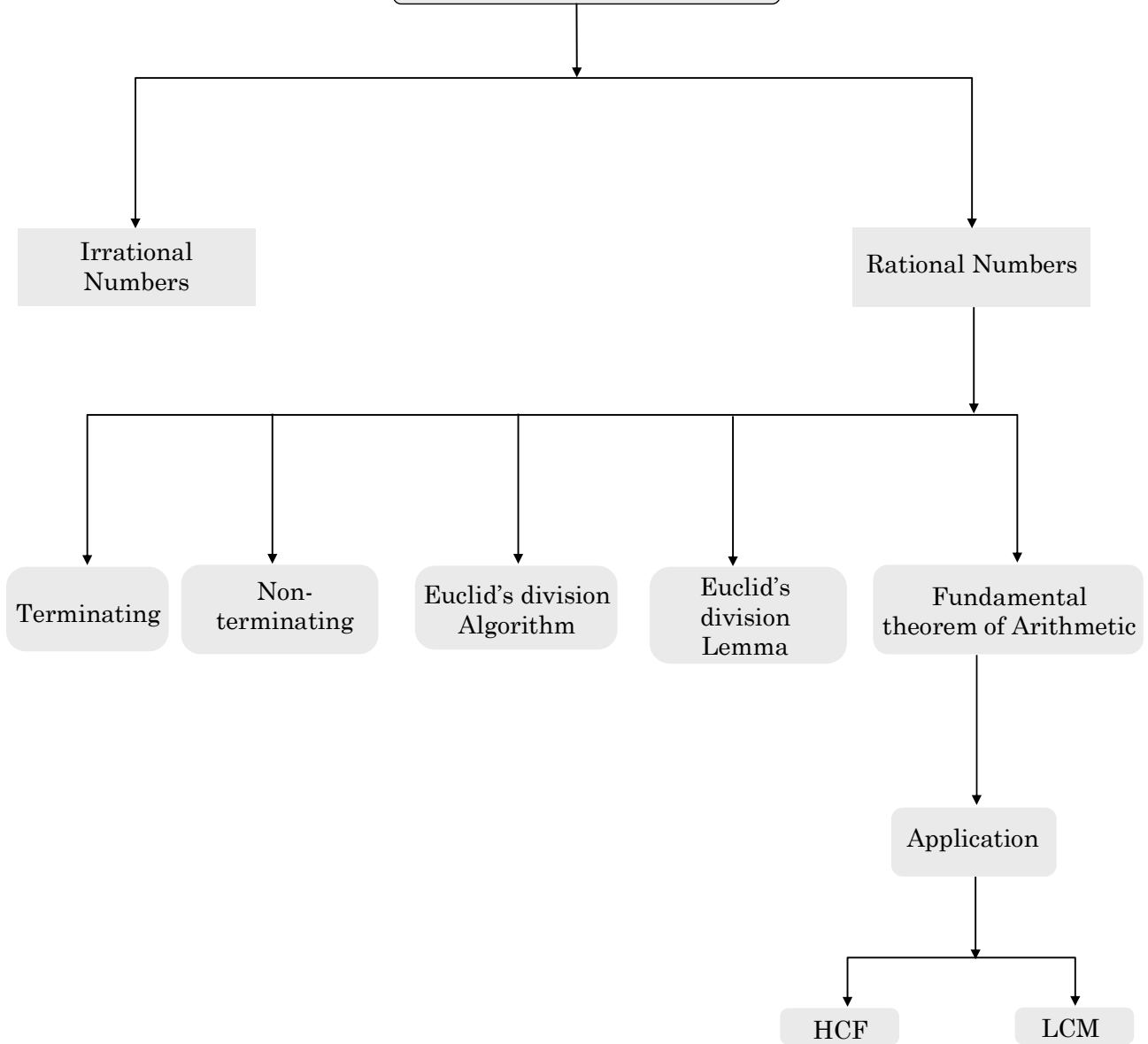

or $\frac{1}{7} = 0.142857142857\dots = 0.\overline{142857}$

$$\begin{array}{r}
 7 \overline{)10} \ (0.14285\dots \\
 \underline{7} \\
 30 \\
 \underline{28} \\
 20 \\
 \underline{14} \\
 60 \\
 \underline{56} \\
 40 \\
 \underline{35} \\
 50 \\
 \underline{49} \\
 1\dots
 \end{array}$$

In both examples remainder never becomes zero so the decimal expansion never ends after some or infinite steps of division. These type of decimal expansions are called non terminating.

Also we can see that on further division a digit of a block of digit repeats itself in the decimal part.

So these are called non terminating recurring decimal expansions.

Both the above types (1 & 2) are rational numbers.

Types (3) :

Eg :The decimal expansion 0.327172398... does not end any where, also there is no arrangement of digits (not repeating) so these are called non terminating not recurring.

These numbers are called irrational numbers.

Eg. :

0.1279312793	rational	terminating
0.1279312793....	rational	non terminating
or $0.\overline{12793}$		& recurring
0.32777	rational	terminating
$0.3\overline{27}$	or rational	non terminating
0.32777.....		& recurring
0.5361279	rational	terminating
0.10100100010000	rational	terminating
0.10100100010000....	irrational	non terminating
		non recurring.

Theorem-1 : Let p be a prime number. If p divides a^2 , then p divides a, where a is a positive integer.

Proof : Let the prime factorisation of a be as follows :

$a = p_1 p_2 \dots p_n$, where p_1, p_2, \dots, p_n are primes, not necessarily distinct.

Therefore,

$a^2 = (p_1 p_2 \dots p_n) (p_1 p_2 \dots p_n) = p_1^2 p_2^2 \dots p_n^2$.

Now, we are given that p divides a^2 . Therefore, from the Fundamental Theorem of Arithmetic, it follows that p is one of the prime factors of a^2 . However, using the uniqueness part of the Fundamental Theorem of Arithmetic, we realise that the only prime factors of a^2 are p_1, p_2, \dots, p_n . So p is one of p_1, p_2, \dots, p_n .

Now, since $a = p_1 p_2 \dots p_n$, p divides a.

Ex.1 Prove that $\sqrt{2}$ is irrational number

Sol. Let us assume, to contrary, that $\sqrt{2}$ is rational. That is, we can find integers a and b ($a, b \neq 0$) such that $\sqrt{2} = \frac{a}{b}$. Where a and b are coprime i.e. their H.C.F. = 1

So, $b\sqrt{2} = a$.

Squaring on both sides, and rearranging, we get $2b^2 = a^2$.

Therefore, a^2 is divisible by 2, and by Theorem 1, it follows that a is also divisible by 2.

So, we can write $a = 2c$ for some integer c .

Substituting for a , we get $2b^2 = 4c^2$,

That is, $b^2 = 2c^2$.

This means that b^2 is divisible by 2, and so b is also divisible by 2.

Therefore, a and b have at least 2 as a common factor.

But this contradicts the fact that a and b are coprime.

This contradiction has arisen because of our incorrect assumption that $\sqrt{2}$ is rational.

So, we conclude that $\sqrt{2}$ is irrational.

Euclid's Division Lemma

For any two positive integers a and b , there exist unique integers q and r satisfying $a = bq + r$, where $0 \leq r < b$.

For Example

(i) Consider number 23 and 5, then:

$$23 = 5 \times 4 + 3$$

Comparing with $a = bq + r$; we get:

$$a = 23, b = 5, q = 4, r = 3$$

and $0 \leq r < b$ (as $0 \leq 3 < 5$).

(ii) Consider positive integers 18 and 4.

$$18 = 4 \times 4 + 2$$

\Rightarrow For $a = 18$ and $b = 4$ we have $q = 4$,

$$r = 2 \text{ and } 0 \leq r < b.$$

In the relation $a = bq + r$, where $0 \leq r < b$ is nothing but a statement of the long division of number a by number b in which q is the quotient obtained and r is the remainder.

Thus,

dividend = divisor \times quotient + remainder

$$\Rightarrow a = bq + r$$

◆ H.C.F. (Highest Common Factor)

The H.C.F. of two or more positive integers is the largest positive integer that divides each given positive number completely.

For Example

(i) 14 is the largest positive integer that divides 28 and 70 completely; therefore H.C.F. of 28 and 70 is 14.

(ii) H.C.F. of 75, 125 and 200 is 25 as 25 divides each of 75, 125 and 200 completely and so on.

Euclid's Division Algorithm

If 'a' and 'b' are positive integers such that $a = bq + r$, then every common divisor of 'a' and 'b', is a common divisor of 'b' and 'r', and vice-versa.

- Using Euclid's Division Algorithm For Finding H.C.F.

Consider positive integers 418 and 33.

Step-1

Taking bigger number (418) as a and smaller number (33) as b

express the numbers as $a = bq + r$

$$\Rightarrow 418 = 33 \times 12 + 22$$

Step-2

Now taking the divisor 33 as a and remainder 22 as b apply the Euclid's division algorithm to get:

$$33 = 22 \times 1 + 11 \quad [\text{Expressing as } a = bq + r]$$

Step-3

Again with new divisor 22 as a and new remainder 11 as b apply the Euclid's division algorithm to get:

$$22 = 11 \times 2 + 0$$

Step-4

Since, the remainder = 0 so we cannot proceed further.

Step-5

The last divisor is 11 and we say H.C.F. of 418 and 33 is 11

Verification :

- (i) Using factor method:

\therefore Factors of 418 = 1, 2, 11, 19, 22, 38, 209 and 418 and,

Factor of 33 = 1, 3, 11 and 33.

Common factors = 1 and 11

\Rightarrow Highest common factor = 11 i.e., H.C.F. = 11

- (ii) Using prime factor method:

Prime factors of 418 = 2, 11 and 19.

Prime factors of 33 = 3 and 11.

\therefore H.C.F. = Product of all common prime factors = 11. For any two positive integers a and b which can be expressed as, $a = bq + r$, where $0 \leq r < b$, the, H.C.F. of (a, b) = H.C.F. of (q, r) and so on.

For number 418 and 33

$$418 = 33 \times 12 + 22$$

$$33 = 22 \times 1 + 11$$

and $22 = 11 \times 2 + 0$

\Rightarrow H.C.F. of (418, 33) = H.C.F. of (33, 22) = H.C.F. of (22, 11) = 11.

Ex.2 Using Euclid's division algorithm, find the H.C.F. of

(i) 135 and 225

(ii) 196 and 38220

Sol. (i) Starting with the larger number i.e., 225, we get : $225 = 135 \times 1 + 90$
 Now taking divisor 135 and remainder 90, we get : $135 = 90 \times 1 + 45$
 Further taking divisor 90 and remainder 45, we get : $90 = 45 \times 2 + 0$
 \therefore Required H.C.F. = 45

(ii) Starting with larger number 38220, we get : $38220 = 196 \times 195 + 0$
 Since, the remainder is 0
 \Rightarrow H.C.F. = 196

Ex.3 Show that any positive odd integer is of the form $4q + 1$ or $4q + 3$, where q is some integer.

Sol. Let a and b be two positive integers where a is greater than b . According to Euclid's division lemma; a and b can be expressed as

$a = bq + r$, where q is quotient and r is remainder and $0 \leq r < b$.

Taking $b = 4$, we get

$a = 4q + r$,

where $0 \leq r < 4$ i.e., $r = 0, 1, 2$ or 3

$r = 0 \Rightarrow a = 4q$, which is divisible by 2 and so is even.

$r = 1 \Rightarrow a = 4q + 1$, which is not divisible by 2 and so is odd.

$r = 2 \Rightarrow a = 4q + 2$, which is divisible by 2 and so is even.

and $r = 3 \Rightarrow a = 4q + 3$, which is not divisible by 2 and so is odd.

\therefore Any positive odd integer is of the form

$4q + 1$ or $4q + 3$; where q is an integer.

Ex.4 Use Euclid's Division Algorithm to show that the square of any positive integer is either of the form $3m$ or $3m + 1$ for some integer m .

Sol. Let a and b are two positive integers such that a is greater than b ; then:

$a = bq + r$; where q and r are also positive integers and $0 \leq r < b$

Taking $b = 3$, we get:

$a = 3q + r$; where $0 \leq r < 3$

\Rightarrow The value of positive integer a will be $3q + 0, 3q + 1$ or $3q + 2$

i.e., $3q, 3q + 1$ or $3q + 2$.

Now we have to show that the squares of positive integers $3q, 3q + 1$ and $3q + 2$ can be expressed as $3m$, or $3m + 1$ for some integer m .

\therefore Square of $3q = (3q)^2$

$= 9q^2 = 3(3q^2) = 3m$; 3 where m is some integer.

Square of $3q + 1 = (3q + 1)^2$

$= 9q^2 + 6q + 1$

$= 3(3q^2 + 2q) + 1 = 3m + 1$ for some integer m .

Square of $3q + 2 = (3q + 2)^2$

$= 9q^2 + 12q + 4$

$= 9q^2 + 12q + 3 + 1$

$= 3(3q^2 + 4q + 1) + 1 = 3m + 1$ for some integer m .

\therefore The square of any positive integer is either of the form $3m$ or $3m + 1$ for some integer m .

COMPETITIVE LEVEL

Note :

- (i) $(x^n - a^n)$ is divisible by $(x - a)$ for all the values of n .
- (ii) $(x^n - a^n)$ is divisible by $(x + a)$ for all even values of n .
- (iii) $(x^n + a^n)$ is divisible by $(x + a)$ for all odd values of n .

◆ Euclid Division Algorithm

$$\text{Dividend} = (\text{Divisor} \times \text{Quotient}) + \text{Remainder}$$

Ex.5 On dividing 20032 by a certain number, the quotient is 101 and the remainder is 135. Find the divisor.

Sol.
$$\text{Divisor} = \frac{\text{Dividend} - \text{Remainder}}{\text{Quotient}} = \frac{20032 - 135}{101} = 197.$$

Test of Divisibility :

No.	Divisibility Test
2	Unit digit should be 0 or even.
3	The sum of digits of no. should be divisible by 3.
4	The no. formed by last 2 digits of given no. should be divisible by 4.
5	Unit digit should be 0 or 5.
6	No. should be divisible by 2 & 3 both.
7	No. without ones - 2(ones) = no. should be 0 or divisible by 7.
8	The number formed by last 3 digits of given no. should be divisible by 8.
9	Sum of digits of given no. should be divisible by 9.
11	The difference between sums of the digits at even & at odd places should be zero or multiple of 11.
13	No. without ones + 4 (ones digit) = no. should be divisible by 13.
17	No. without ones - 5(ones) = no. should be 0 or divisible by 17.
19	No. without ones + 2(ones) = no. should be divisible by 19.
25	Last 2 digit of the number should be 00, 25, 50 or 75.

The Fundamental Theorem Of Arithmetic

Statement : Every composite number can be decomposed as product of prime numbers in a unique way, except for the order in which the prime numbers occur.

For example :

(i) $30 = 2 \times 3 \times 5, 30 = 3 \times 2 \times 5, 30 = 2 \times 5 \times 3$ and so on.

(ii) $432 = 2 \times 2 \times 2 \times 2 \times 3 \times 3 \times 3 = 2^4 \times 3^3$

or $432 = 3^3 \times 2^4.$

(iii) $12600 = 2 \times 2 \times 2 \times 3 \times 3 \times 5 \times 5 \times 7 = 2^3 \times 3^2 \times 5^2 \times 7$

In general, a composite number is expressed as the product of its prime factors written in ascending order of their values.

E.g., (i) $6615 = 3 \times 3 \times 3 \times 5 \times 7 \times 7 = 3^3 \times 5 \times 7^2$

(ii) $532400 = 2 \times 2 \times 2 \times 2 \times 5 \times 5 \times 11 \times 11 \times 11 = 2^4 \times 5^2 \times 11^3$

Ex.6 Consider the number 12^n , where n is a natural number. Check whether there is any value of $n \in \mathbb{N}$ for which 12^n ends with the digit zero.

Sol. We know, if any number ends with the digit zero it is always divisible by 5.

\Rightarrow If 12^n ends with the digit zero, it must be divisible by 5.

This is possible only if prime factorisation of 12^n contains the prime number 5.

Now, $12 = 2 \times 2 \times 3 = 2^2 \times 3$

$\Rightarrow 12^n = (2^2 \times 3)^n = 2^{2n} \times 3^n$

i.e., prime factorisation of 12^n does not contain the prime number 5.

\Rightarrow There is no value of $n \in \mathbb{N}$ for which

12^n ends with the digit zero.

◆ **The Factor Tree :**

Ex.7 Find the prime factors of 540.

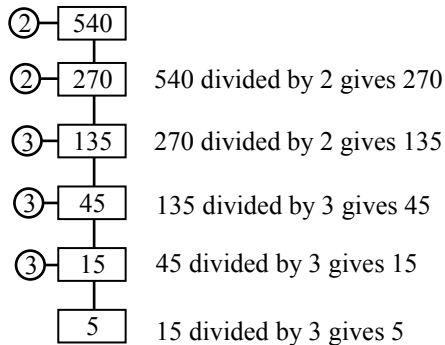

5 is a prime number and so cannot be further divided by any prime number

$\therefore 540 = 2 \times 2 \times 3 \times 3 \times 3 \times 5 = 2^2 \times 3^3 \times 5$

Ex.8 Find the missing numbers a , b and c in the following factorisation:

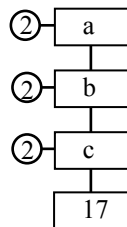

Can you find the number on top without finding the other ?

Sol. $c = 17 \times 2 = 34$

$b = c \times 2 = 34 \times 2 = 68$ and

$a = b \times 2 = 68 \times 2 = 136$

i.e., $a = 136$, $b = 68$ and $c = 34$.

Yes, we can find the number on top without finding the others.

Reason: The given numbers 2, 2, 2 and 17 are the only prime factors of the number on top and so the number on top $= 2 \times 2 \times 2 \times 17 = 136$

COMPETITIVE LEVEL

Number of factors : For any composite number C , which can be expressed as $C = a^p \times b^q \times c^r \times \dots$, where a, b, c, \dots are all prime factors and p, q, r are positive integers, the number of factors is equal to $(p + 1) \times (q + 1) \times (r + 1) \dots$

For example $36 = 2^2 \times 3^2$. So the factors of $36 = (2 + 1) \times (2 + 1) = 3 \times 3 = 9$.

Ex.9 If $N = 18^4 \times 2^3 \times 5^5$, find the total number of even factors of N .

Sol. The factorised form of N is

$$(3^2 \times 2)^4 \times 2^3 \times 5^5 \Rightarrow 3^8 \times 2^7 \times 5^5.$$

Hence, the total number of factors of N is $(8 + 1)(7 + 1)(5 + 1) = 9 \times 8 \times 6 = 432$.

Some of these are odd and some are even. The odd are formed only with the combination of 3s and 5s.

So, the total number of odd factors is

$$(8 + 1)(5 + 1) = 54.$$

Therefore, the number of even factors is

$$432 - 54 = 378.$$

Ex.10 A number N when factorised can be written $N = a^4 \times b^3 \times c^7$. Find the number of perfect squares which are factors of N (The three prime numbers $a, b, c > 2$).

Sol. In order that the perfect square divides N , the powers of 'a' can be 0, 2 or 4.

Powers of 'b' can be 0, 2. Power of 'c' can be 0, 2, 4 or 6.

Hence, a combination of these powers given $3 \times 2 \times 4$ i.e. 24 numbers.

So, there are 24 perfect squares that divides N .

To Find H.C.F and L.C.M. Using The Fundamental Theorem Of Arithmetic

Ex.11 The L.C.M. and H.C.F. of the following pairs of integers by applying the Fundamental theorem of Arithmetic method i.e., using the prime factorisation method.

(i) 26 and 91 (ii) 1296 and 2520

Sol. (i) Since, $26 = 2 \times 13$ and, $91 = 7 \times 13$

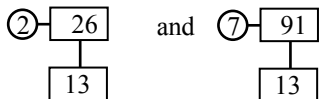

\therefore L.C.M. = Product of each prime factor with highest powers. = $2 \times 13 \times 7 = 182$.

i.e., L.C.M. (26, 91) = 182.

H.C.F. = Product of common prime factors with lowest powers. = 13.

i.e., H.C.F (26, 91) = 13.

(ii) Since, $1296 = 2 \times 2 \times 2 \times 2 \times 3 \times 3 \times 3 \times 3 = 2^4 \times 3^4$

and, $2520 = 2 \times 2 \times 2 \times 3 \times 3 \times 5 \times 7$

$$= 2^3 \times 3^2 \times 5 \times 7$$

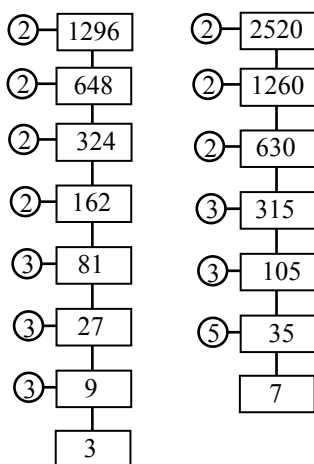

∴ L.C.M. = Product of each prime factor with highest powers

$$= 2^4 \times 3^4 \times 5 \times 7 = 45,360$$

i.e., L.C.M. (1296, 2520) = 45,360

H.C.F. = Product of common prime factors with lowest powers.

$$= 2^3 \times 3^2 = 8 \times 9 = 72$$

i.e., H.C.F. (1296, 2520) = 72.

For any two positive integers :

Their L.C.M. \times their H.C.F. = Product of the number

$$(i) \text{ L.C.M.} = \frac{\text{Product of the numbers}}{\text{H.C.F.}}$$

$$(ii) \text{ H.C.F.} = \frac{\text{Product of the numbers}}{\text{L.C.M.}}$$

$$(iii) \text{ One number} = \frac{\text{L.C.M.} \times \text{H.C.F.}}{\text{Other number}}$$

Ex.12 Given that H.C.F. (306, 657) = 9,

find L.C.M. (306, 657)

Sol. H.C.F. (306, 657) = 9

To find L.C.M. (306, 657)

For any two positive integers;

$$\text{their L.C.M.} = \frac{\text{Product of the numbers}}{\text{Their H.C.F.}}$$

$$\text{i.e., L.C.M. (306, 657)} = \frac{306 \times 657}{9} = 22,338.$$

Ex.13 The H.C.F. and L.C.M. of two numbers are 12 and 240 respectively. If one of these numbers is 48; find the other numbers.

Sol. Since, the product of two numbers

$$= \text{Their H.C.F.} \times \text{Their L.C.M.}$$

$$\Rightarrow \text{One no.} \times \text{other no.} = \text{H.C.F.} \times \text{L.C.M.}$$

$$\Rightarrow \text{Other no.} = \frac{12 \times 240}{48} = 60.$$

Ex.14 Explain why $7 \times 11 \times 13 + 13$ and $7 \times 6 \times 5 \times 4 \times 3 + 5$ are composite numbers.

Sol. Since,

$$\begin{aligned}7 \times 11 \times 13 + 13 &= 13 \times (7 \times 11 + 1) \\ &= 13 \times 78 = 13 \times 13 \times 3 \times 2;\end{aligned}$$

that is, the given number has more than two factors and it is a composite number.

Similarly, $7 \times 6 \times 5 \times 4 \times 3 + 5$

$$\begin{aligned}&= 5 \times (7 \times 6 \times 4 \times 3 + 1) \\ &= 5 \times 505 = 5 \times 5 \times 101\end{aligned}$$

\Rightarrow The given no. is a composite number.

COMPETITIVE LEVEL

HCF and LCM of fractions :

$$\text{LCM of fractions} = \frac{\text{LCM of numerators}}{\text{HCF of denominators}}$$

$$\text{HCF of fractions} = \frac{\text{HCF of numerators}}{\text{LCM of denominators}}$$

Make sure the fractions are in the most reducible form.

Ex.15 Find a number which when divided by 3, 4, and 13 always leaves the same remainder 2.

Sol. The smallest number which, when divided by 3, 4 and 13, leaves the remainder 2 in each case is $\text{LCM}(3, 4 \text{ and } 13) + 2 = 156 + 2 = 158$

Ex.16 Find the H.C.F. and L.C.M. of $\frac{2}{3}$, $\frac{8}{9}$, $\frac{16}{81}$ and $\frac{10}{27}$.

$$\text{Sol. H.C.F. of given fractions} = \frac{\text{H.C.F. of } (2, 8, 16, 10)}{\text{L.C.M. of } (3, 9, 81, 27)} = \frac{2}{81},$$

$$\text{L.C.M. of given fractions} = \frac{\text{L.C.M. of } (2, 8, 16, 10)}{\text{H.C.F. of } (3, 9, 81, 27)} = \frac{80}{3}.$$

Logarithm

If 'a' is a positive real number, other than 1 and x is a real number such that $a^x = N$, then x is the logarithm of N to the base a.

$$\text{If } a^x = N \text{ then } \log_a N = x.$$

Where $N > 0$ and $a > 0, a \neq 1$

Systems of Logarithm

There are two systems of logarithm which are generally used.

(i) Common logarithm : In this system base is always taken as 10.

(ii) Natural logarithm : In this system the base of the logarithm is taken as 'e'. Where 'e' is an irrational number lying between 2 and 3. (The approximate value of e upto two decimal places is equal to 2.73)

Fundamental Laws of Logarithm

Logarithm to any base a (where $a > 0$ and).

(i) $\log_a a = 1$

(ii) $\log_a 0 = \text{not defined}$ [As $a^n = 0$ is not possible, where n is any number]

(iii) $\log_a (-\text{ve no.}) = \text{not defined.}$ [As in $\log_a N$, N will always be (+ ve)]

(iv) $\log_a (mn) = \log_a m + \log_a n$ [Where m and n are +ve numbers]

(v) $\log_a \left(\frac{m}{n} \right) = \log_a m - \log_a n$

(vi) $\log_a (m)^n = n \log_a m$

(vii) $\log_a m = \frac{\log_b m}{\log_b a}$

(viii) $\log_a m \cdot \log_m a = 1$

(ix) $a^{\log_a n} = n$

(x) $\log_{a^q} n^p = \frac{p}{q} \log_a n, n > 0$

(xi) $p^{\log_a q} = q^{\log_a p}, n > 0$

(xii) $\log_a x = \log_a y, x = y$

Ex.17 Find the value of $\log \frac{9}{8} - \log \frac{27}{32} + \log \frac{3}{4}$

Sol. Given :

$$\begin{aligned} \log \frac{9}{8} - \log \frac{27}{32} + \log \frac{3}{4} &= \log \left(\frac{9}{8} \div \frac{27}{32} \right) + \log \frac{3}{4} \\ &= \log \left(\frac{9}{8} \times \frac{32}{27} \times \frac{3}{4} \right) = \log 1 = 0. \quad [\log_a 1 = 0] \end{aligned}$$

Ex.18 If $2\log_4 x = 1 + \log_4(x - 1)$, find the value of x .

Sol. Given $2\log_4 x = 1 + \log_4(x - 1)$

$$\Rightarrow \log_4 x^2 - \log_4(x - 1) = 1$$

$$\Rightarrow \log_4 \frac{x^2}{x - 1} = 1$$

$$\Rightarrow 4^1 = \frac{x^2}{x - 1}$$

$$\Rightarrow x^2 = 4x - 4$$

$$\Rightarrow x^2 - 4x + 4 = 0$$

$$\Rightarrow (x - 2)^2 = 0 \quad x = 2.$$

Ex.19 If $A = \log_{27} 625 + 7^{\log_{11} 13}$ and $B = \log_9 125 + 13^{\log_{11} 7}$, then find the relation between A and B.

Sol. $A = \log_{27} 625 + 7^{\log_{11} 13} = \log_{3^3} 5^4 + 7^{\log_{11} 13}$

or, $A = \frac{4}{3} \log_3 5 + 7^{\log_{11} 13} \quad \dots(i)$

and, $B = \log_9 125 + 13^{\log_{11} 7}$

or, $B = \log_{3^2} 5^3 + 7^{\log_{11} 13}$

or, $B = \frac{3}{2} \log_3 5 + 7^{\log_{11} 13} \quad \dots(ii)$

By (i) and (ii) we have,

$$A - \frac{4}{3} \log_3 5 = B - \frac{3}{2} \log_3 5$$

$$\therefore \frac{4}{3} \log_3 5 < \frac{3}{2} \log_3 5 \quad \therefore A < B.$$

Highest Power Dividing Factorial

Factorial n : Product of n consecutive natural numbers starting from 1 is known as 'factorial n' it is denoted by 'n!'.

So, $n! = n.(n-1).(n-2)...3.2.1$. e.g. $5! = 5 \times 4 \times 3 \times 2 \times 1 = 120$.

The value of factorial zero is equal to the value of factorial one. Hence $0! = 1 = 1!$

The approach to finding the highest power of x dividing y! is $\left[\frac{y}{x} \right] + \left[\frac{y}{x^2} \right] + \left[\frac{y}{x^3} \right] \dots$, where [] represents just the integral part of the answer and ignoring the fractional part.

Ex.20 What is the highest power of 2 that divides 20! completely?

Sol. $20! = 1 \times 2 \times 3 \times 4 \times \dots \times 18 \times 19 \times 20 = 1 \times (2^1) \times 3 \times (2^2) \times 5 \times (2^1 \times 3^1) \times 7 \times (2^3) \times \dots$ so on. In order to find the highest power of 2 that divides the above product, we need to find the sum of the powers of all 2 in this expansion. All numbers that are divisible by 2^1 will contribute 1 to the exponent of 2 in the product = 10. Hence, 10 numbers contribute 2^1 to the product. Similarly, all numbers that are divisible by 2^2 will contribute an extra 1 to the exponent of 2 in the product, i.e. $\frac{20}{2^2} = 5$. Hence, 5 numbers contribute an extra 1 to exponents. Similarly, there are 2 numbers that are divisible by 2^3 and 1 number that is divisible by 2^4 . Hence, the total 1s contributed to the exponent of 2 in 20! is the sum of $(10 + 5 + 2 + 1) = 18$. Hence, group of all 2s in 20! gives $2^{18} \times (N)$, where N is not divisible by 2.

If 20! is divided by 2^x then maximum value of x is 18.

Ex.21 How many zeros at the end of first 100 multiples of 10.

Sol. First 100 multiple of 10 are = $10 \times 20 \times 30 \times \dots \times 1000$
 $= 10^{100} (1 \times 2 \times 3 \times \dots \times 100)$
 $= 10^{100} \times 10^{24} \times N$
 $= 10^{124} \times N$

Where N is not divisible by 10

So, there are 124 zero at the end of first 100 multiple of 10.

EXERCISE-1

Very Short Answer Type Questions

Q.1 Classify the following numbers as rational or irrational :

- (i) $\frac{22}{7}$ (ii) 3.1416
(iii) π (iv) $\overline{3.142857}$
(v) 5.636363..... (vi) 2.040040004.....
(vii) 1.535335333.... (viii) 3.121221222...
(ix) $\sqrt{21}$ (x) $\sqrt[3]{3}$

Q.2 Prove that $\frac{1}{\sqrt{3}}$ is irrational.

Q.3 Define Euclid's Division Lemma.

Q.4 A number when divided by 61 gives 27 as quotient and 32 as remainder. Find the number.

Q.5 By what number should 1365 be divided to get 31 as quotient and 32 as remainder ?

Short Answer Type Questions – Type I

Q.6 Find two irrational numbers between 3 and 4.

Q.7 Find two irrational numbers between 2 and 2.5.

Q.8 Consider the number 6^n , where n is a natural number. Check whether there is any value of $n \in \mathbb{N}$ for which 6^n is divisible by 7.

Q.9 Prove that each of the following numbers is irrational :

- (i) $\sqrt{6}$ (ii) $(2 - \sqrt{3})$
(iii) $(3 + \sqrt{2})$ (iv) $(2 + \sqrt{5})$
(v) $(5 + 3\sqrt{2})$ (vi) $3\sqrt{7}$
(vii) $\frac{3}{\sqrt{5}}$ (viii) $(2 - 3\sqrt{5})$
(ix) $(\sqrt{3} + \sqrt{5})$

Q.10 Without actual division, show that each of the following rational numbers is a non-terminating repeating decimal :

- (i) $\frac{11}{(2^3 \times 3)}$ (ii) $\frac{73}{(2^3 \times 3^3 \times 5)}$
(iii) $\frac{9}{35}$ (iv) $\frac{32}{147}$
(v) $\frac{64}{455}$ (vi) $\frac{77}{210}$
(vii) $\frac{29}{343}$ (viii) $\frac{129}{(2^2 \times 5^7 \times 7^5)}$

Short Answer Type Questions – Type II

Q.11 Without actual division, show that each of the following rational numbers is a terminating decimal. Express each in decimal form :

- (i) $\frac{23}{(2^3 \times 5^2)}$ (ii) $\frac{24}{125}$ (iii) $\frac{17}{320}$
(iv) $\frac{171}{800}$ (v) $\frac{15}{1600}$ (vi) $\frac{19}{3125}$

Q.12 Express each of the following as a fraction in simplest form :

- (i) $0.\overline{8}$ (ii) $2.\overline{4}$ (iii) $0.\overline{24}$
(iv) $0.\overline{12}$ (v) $2.\overline{24}$ (vi) $0.\overline{365}$

Q.13 Using prime factorisation, find the HCF and LCM of

- (i) 144, 198 (ii) 396, 1080
(iii) 1152, 1664 (iv) 21, 28, 36, 45

Q.14 The HCF of two numbers is 23 and their LCM is 1449. If one of the numbers is 161, find the other.

Q.15 Find the [HCF \times LCM] for the numbers 105 and 120.

Q.16 Three pieces of timber 42 m, 49 m and 63 m long have to be divided into planks of the same length. What is the greatest possible length of each plank ?

- Q.17** Find the greatest possible length which can be used to measure exactly the length 7 m, 3 m 85 cm and 12 m 95 cm.
- Q.18** Three sets of English, Mathematics and Science books containing 336, 240 and 96 books respectively have to be stacked in such a way that all the books are stored subject wise and the height of each stack is the same. How many stacks will be there ?
- Q.19** Three measuring rods are 64 cm, 80 cm and 96 cm in length. Find the least length of cloth that can be measured an exact number of times, using any of the rods.
- Q.20** The traffic lights at three different road crossings change after every 48 seconds, 72 seconds and 108 seconds respectively. If they all change simultaneously at 8 a.m., then at what time will they again change simultaneously ?
- Q.24** Show that one and only one out of n , $n + 2$ or $n + 4$ is divisible by 3, where n is any positive integer
- Q.25** Find the least number of square tiles required to pave the ceiling of a room 15 m 17 cm long and 9 m 2 cm broad.
- Q.26** Six bells commence tolling together and toll at intervals of 2, 4, 6, 8, 10, 12 minutes respectively. In 30 hours, how many times do they toll together ?
- Q.27** Show that there is no positive integer n , for which $\sqrt{n-1} + \sqrt{n+1}$ is rational.
- Q.28** Find HCF of 81 and 237 and express it as a linear combination of 81 and 237 i.e., $\text{HCF}(81, 237) = 81x + 237y$ for some x and y . Find the value of x and y .
- Q.29** Three friends Salman, Hritik & John were good friends. They need to go for morning walk together, on a morning walk, they step off together & their steps measure 40 cm, 42 cm, & 45 cm respectively.

➤ Long Answer Type Questions

- Q.21** An electronic device makes a beep after every 60 seconds. Another device makes a beep after every 62 seconds. They beeped together at 10 am. At what time will they beep together at the earliest ?
- Q.22** Using Euclid's algorithm, find the HCF of
 (i) 405 and 2520
 (ii) 504 and 1188
 (iii) 960 and 1575
- Q.23** Show that any positive integer which is of the form $6q + 1$ or $6q + 3$ or $6q + 5$ is odd, where q is some integer.
- (a) What is minimum distance each should walk so that each can cover same distance in complete steps ?
 (b) What you have learnt (values/lesson) from above activity of three friends.
- Q.30** Aakriti decided to distribute milk in an orphanage on her birthday. The supplier brought two milk containers which contain 398 l and 436 l of milk. The milk is to be transferred to another containers so 7 l and 11 l of milk is left in both the containers respectively
 (a) What will be the maximum capacity of the drum?
 (b) What qualities/ values were shown by Aakriti ?

EXERCISE-2

- Q.1** The product of the digits of a four digit number is 540. If the digits are all different find the greatest digit out of them if the least is 2.
 (A) 5 (B) 6
 (C) 9 (D) None of these
- Q.2** How many natural numbers are there which satisfy $n^2 < 8n < 35n < n^3$.
 (A) 1 (B) 2 (C) 3 (D) 4
- Q.3** xy is a number that is divided by ab where $xy < ab$ and gives a result $0.xyxyxy\dots$ then ab equals :
 (A) 11 (B) 33 (C) 99 (D) 66
- Q.4** Given that a, b are odd and c, d are even, then
 (A) $a^2 - b^2 + c^2 - d^2$ is always divisible by 4
 (B) $abc + bcd + cda + dab$ is always divisible by 4
 (C) $a^4 + b^4 + c^3 + d^3 + c^2b + a^2b$ is always odd
 (D) $a + 2b + 3c + 4d$ is odd
- Q.5** If $a, a + 2$, and $a + 4$ are prime numbers, then the number of possible solution for a is -
 (A) three (B) two
 (C) one (D) more than three
- Q.6** There are four prime numbers written in ascending order. The product of the first three is 385 and that of the last three is 1001. The last number is :
 (A) 11 (B) 13 (C) 17 (D) 19
- Q.7** In a six digit number 5 digits are prime numbers. The sum of all the digits is 24. The 2nd, 3rd and 5th digit are identical and the others are distinct digits. The number is divisible by 4. The last digit of the number is
 (A) 2 or 4 (B) 4 or 6
 (C) 4 or 6 or 8 (D) 2 or 6 or 8
- Q.8** The number of positive n in the range $12 \leq n \leq 40$ such that the product $(n-1)(n-2)\dots 3.2.1$ is not divisible by n is :
 (A) 5 (B) 7 (C) 13 (D) 14
- Q.9** If least prime factor of a number m is 3 and least prime factor of another number n is 7, then least prime factor of the number $(m+n)$ is :
 (A) 2 (B) 3 (C) 5 (D) 7
- Q.10** V is product of first 41 natural numbers. $A = V + 1$. The number of primes among $A + 1, A + 2, A + 3, A + 4, \dots, A + 39, A + 40$ is :
 (A) 1 (B) 2 (C) 3 (D) 0
- Q.11** If N denotes the number of digits in the number $(5^{84})(2^{86})$ then N equals
 (A) 83 (B) 84
 (C) 85 (D) 88
- Q.12** How many pairs of positive integers (n, m) , with $n \leq m$ satisfy the equation $\frac{1}{5} = \frac{1}{n} + \frac{1}{m}$?
 (A) 1 (B) 2 (C) 3 (D) 4
- Q.13** If $a^2 - b^2 = 13$ where a and b are natural numbers, then value of a is :
 (A) 6 (B) 7 (C) 8 (D) 9
- Q.14** Find the number of divisors of $2^7 \times 3^8 \times 5^9$ -
 (A) 504 (B) 720
 (C) 724 (D) 540
- Q.15** Find the least number which when divided by 15, leaves a remainder of 5, when divided by 25, leaves a remainder of 15 and when divided by 35 leaves a remainder of 25.
 (A) 515 (B) 525
 (C) 1040 (D) 1050
- Q.16** If $\text{HCF}(p, q) = 12$ and $p \times q = 1800$ then $\text{LCM}(p, q)$ is :
 (A) 3600 (B) 900
 (C) 150 (D) 90

- Q.17** The least number of square tiles required to pave the ceiling of a room 15 m 17 cm long and 9 m 2 cm broad, is :
(A) 902 (B) 656 (C) 738 (D) 814
- Q.18** Four watches are ringing alarm bells in the interval of 6, 12, 15 and 18 seconds. If they start at same time, how many times they will ring together in 4 hrs.
(A) 80 times (B) 81 times
(C) 20 times (D) 21 times
- Q.19** If $4^{25} + 5^{15}$ is divided by 10, then the remainder is :
(A) 4 (B) 5 (C) 9 (D) 0
- Q.20** Number of values of 'a' (from 0 to 9) for the number $N = 2345631143a4$ is divisible by 12, is :
(A) 0 (B) 1
(C) 2 (D) more than 2
- Q.21** $1^{13} + 2^{13} + 3^{13} + \dots + 60^{13}$ is divisible by :
(A) 61 (B) 63
(B) 65 (D) 59
- Q.22** The value of the digit d for which the number d456d is divisible by 18, is :
(A) 3 (B) 4 (C) 6 (D) 9
- Q.23** The smallest integral value of x, for which $\frac{7}{x}$ is an integer is :
(A) 1 (B) -1 (C) 7 (D) -7
- Q.24** $19^n - 1$ is -
(A) always divisible by 9
(B) always divisible by 20
(C) is never divisible by 19
(D) only (A) and (C) are true
- Q.25** Which one of the numbers listed below is not a divisor of the number $N = (2^{30} - 1)$, is equal to :
(A) $2^5 - 1$ (B) $2^5 + 1$
(C) $2^6 - 1$ (D) $2^{10} + 1$
- Q.26** The least number which on division by 35 leaves a remainder 25 and on division by 45 leaves the remainder 35 and on division by 55 leaves the remainder 45 is:
(A) 2515 (B) 3455
(C) 2875 (D) 2785
- Q.27** When $4^{101} + 6^{101}$ is divided by 25, the remainder is :
(A) 20 (B) 10 (C) 5 (D) 0
- Q.28** What is the remainder when 13^{400} is divided by 11?
(A) -1 (B) 1 (C) 5 (D) 2
- Q.29** The greatest value assumed by the function $f(x) = 5 - |x - 3|$ is :
(A) 3 (B) 8 (C) 6 (D) 5
- Q.30** If $x < -2$, then $|1 - |1 + x||$ equals :
(A) $2 + x$ (B) x
(C) $-x$ (D) $-(2 + x)$
- Q.31** If $\log_{10} 2 = 0.30103$, $\log_{10} 3 = 0.47712$, the number of digits in $3^{12} \times 2^8$ is
(A) 7 (B) 8 (C) 9 (D) 10
- Q.32** The value of $\log_3 4 \log_4 5 \log_5 6 \log_6 7 \log_7 8 \log_8 9$ is
(A) 1 (B) 2 (C) 3 (D) 4
- Q.33** The value of $81^{(1/\log_5 3)} + 27^{\log_9 36} + 3^{4/\log_7 9}$ is equal to -
(A) 49 (B) 625
(C) 216 (D) 890
- Q.34** If $\log_4 5 = a$ and $\log_5 6 = b$, then $\log_3 2$ is equal to
(A) $\frac{1}{2a+1}$ (B) $\frac{1}{2b+1}$
(C) $2ab + 1$ (D) $\frac{1}{2ab-1}$
- Q.35** $\log_{10} p + \log_{10} q = \log_{10} (p-q)$, then :
(A) $p = q = 0$ (B) $p = \frac{q}{1+q}$
(C) $p = q = 1$ (D) $p = \frac{q}{1-q}$
- Q.36** Find the number of positive integers which divide 10^{999} but not 10^{998} .
(A) 1999 (B) 1
(C) 999 (D) None of these
- Q.37** The power of 2 in $150!$
(A) 150 (B) 146
(C) 140 (D) 156

- Q.38** Find all real numbers x satisfying
 $x = 2(2(2(2(2x - 1) - 1) - 1) - 1) - 1$
 (A) 15 (B) 2
 (C) 3 (D) None of these

- Q.39** $\frac{1}{2} + \frac{2^1}{2^2} + \frac{2^2}{2^3} + \dots + \frac{2^{2006}}{2^{2007}} + \frac{2^{2007}}{2^{2008}}$ is
 equal to :
 (A) 1004 (B) $\frac{1}{2^{2008}}$
 (C) 2008 (D) 502

- Q.40** If n is a natural number then we define $n!$ (pronounced as factorial n) to be the product $n \times (n - 1) \times (n - 2) \times \dots \times 2 \times 1$. For example $4! = 4 \times 3 \times 2 \times 1 = 24$. If $6! = a! \times b!$ where $a > 1$ and $b > 1$, then $a + b$ is :
 (A) 8 (B) 7 (C) 6 (D) 5

- Q.41** In the sequencea, b, c, d, 0, 1, 1, 2, 3, 5, 8.... each term is the sum of the two terms to its left. Find 'a'.
 (A) -3 (B) -1
 (C) 0 (D) 1

- Q.42** The value of
 $\left(1 - \frac{1}{3}\right)^2 \left(1 - \frac{1}{4}\right)^2 \left(1 - \frac{1}{5}\right)^2 \dots \left(1 - \frac{1}{n}\right)^2$ is
 equal to :
 (A) $\left(\frac{1}{n}\right)^2$ (B) $\left(\frac{2}{n}\right)^2$
 (C) $\left(\frac{3}{n}\right)^2$ (D) $\left(\frac{4}{n}\right)^2$

- Q.43** The value of the expression
 $\sqrt{\frac{1}{\sqrt{2}+1} + \frac{1}{\sqrt{3}+\sqrt{2}} + \frac{1}{\sqrt{4}+\sqrt{3}} + \dots}$ upto 99 terms
 is equal to :
 (A) 9 (B) 3 (C) 1 (D) 0

- Q.44** The number $N = \sqrt[3]{2+\sqrt{5}} + \sqrt[3]{2-\sqrt{5}}$ equals :
 (A) 1 (B) $\sqrt{5} - 1$
 (C) $\sqrt[3]{2}$ (D) $\sqrt{5} - \sqrt[3]{2}$

- Q.45** Find the value of
 $^{507}\sqrt{2\sqrt{7} - 3\sqrt{3}} \cdot ^{1014}\sqrt{55 + 12\sqrt{21}}$
 (A) 1 (B) 2
 (C) 5 (D) None of these

- Q.46** If $\sqrt{9 - (n - 2)^2}$ is a real number, then the number of integral values of n is :
 (A) 3 (B) 5
 (C) 7 (D) Infinitely many

- Q.47** If x is a positive integer less than 100, then the number of x which make
 $\sqrt{1 + 2 + 3 + 4 + \dots + x}$ an integer is:
 (A) 6 (B) 7 (C) 8 (D) 9

- Q.48** If $A^{\frac{1}{A}} = B^{\frac{1}{B}} = C^{\frac{1}{C}}$, $A^{BC} + B^{AC} + C^{AB} = 729$.

Which of the following equals $A^{\frac{1}{A}}$?

- (A) $^{ABC}\sqrt{81}$ (B) $^{ABC}\sqrt{243}$
 (C) $^{ABC}\sqrt{27}$ (D) $^{ABC}\sqrt{9}$

- Q.49** For $x \neq 0, \pm 1$, the expression
 $\frac{\frac{1}{x^{2007}} - \frac{1}{x^{2009}}}{\frac{1}{x^{2008}} - \frac{1}{x^{2010}}}$ is equivalent to :
 (A) x (B) $x - 1$
 (C) $x^2 - 1$ (D) $\frac{1}{x}$

EXERCISE-3

(Previous Year Questions – NTSE, IJSO & IMO)

- Q.1** If a and b are natural numbers such that $\left(\frac{1}{a}\right)^{\frac{1}{b}} = 0.\bar{3}$, then the value of ab is :
(A) 81 (B) 24 (C) 192 (D) 375
- Q.2** If the sum of the digits of a number $(10^n - 1)$ is 4707, where n is a natural number, then the value of n is :
(A) 477 (B) 523 (C) 532 (D) 704
- Q.3** If $5\frac{7}{x} \times y\frac{1}{13} = 12$, where fractions are in their lowest terms, then $x - y$ is equal to
(A) 2 (B) 4 (C) 7 (D) 9
- Q.4** $1x3y6$ is a five digit number where x, y are digits and y exceeds x by 6. If this number is divisible by 18, then the value of $\frac{y}{x}$ is :
(A) 7 (B) 3 (C) $\frac{1}{3}$ (D) $\frac{1}{7}$
- Q.5** The sum of any three distinct natural numbers arranged in ascending order is 200 such that the second number is a perfect cube. How many possible values are there for this number ?
(A) 4 (B) 3 (C) 2 (D) 1
- Q.6** If the digits of a three-digit number are reversed, then the number so obtained is less than the original number by 297. If the sum of the digit of the number is 8 and its hundred's digit has the largest possible value, then the ten's digit of the number is :
(A) 3 (B) 2 (C) 1 (D) 0
- Q.7** Number of zero's in the product of $5 \times 10 \times 25 \times 40 \times 50 \times 55 \times 65 \times 125 \times 80$, is -
(A) 8 (B) 9 (C) 12 (D) 13
- Q.8** A farmer divides his herd of x cows among his 4 son's such that first son gets one-half of the herd, the second son gets one fourth, the third son gets one-fifth and the fourth son gets 7 cows, then the value of x is :
(A) 100 (B) 140
(C) 160 (D) 180
- Q.9** If $\log_{12} 27 = a$, then $\log_6 16$ is
(A) $\frac{4(3-a)}{(3+a)}$ (B) $\frac{4(3+a)}{(3-a)}$
(C) $\frac{(3+a)}{4(3-a)}$ (D) $\frac{3-a}{4(3+a)}$
- Q.10** The value of $4\log\frac{24}{25} - 16\log\frac{9}{10} + 7\log\frac{81}{80}$
(A) $\log 9$ (B) $\log 7$
(C) $\log 5$ (D) $\log 3$
- Q.11** Which real number lies between 2 and 2.5 :
(A) $\sqrt{11}$ (B) $\sqrt{8}$
(C) $\sqrt[3]{7}$ (D) $\sqrt[3]{9}$
- Q.12** For positive x and y , the LCM is 225 and HCF is 15 There.
(A) is exactly one such pair
(B) are exactly two such pair
(C) are exactly three such pair
(D) are exactly four such pair
- Q.13** The HCF of any two prime numbers a and b , is -
(A) a (B) ab (C) b (D) 1
- Q.14** The traffic lights at three different signals change after 48 seconds, 72 seconds and 108. If they change at 7 a.m. simultaneously. How many times they will change between 7 a.m. to 7 : 30 a.m. simultaneously ?
(A) 3 (B) 4 (C) 5 (D) 2

- Q.15** The smallest number which when increased by 17 is exactly divisible by both 520 and 468 is :
 (A) 4697 (B) 4656
 (C) 4663 (D) 4680
- Q.16** Which of the following is an irrational number?
 (A) $\sqrt{41616}$
 (B) 23.232323 ...
 (C) $\frac{(1+\sqrt{3})^3 - (1-\sqrt{3})^3}{\sqrt{3}}$
 (D) 23.10100100010000 ...
- Q.17** On dividing a natural number by 13, the remainder is 3 and on dividing the same number by 21, the remainder is 11. If the number lies between 500 and 600, then the remainder on dividing the number by 19 is -
 (A) 4 (B) 6 (C) 9 (D) 13
- Q.18** Expressing $0.\overline{34} + 0.\overline{34}$ as a single decimal, we get -
 (A) $0.\overline{6788}$ (B) $0.\overline{689}$
 (C) $0.\overline{6878}$ (D) $0.\overline{687}$
- Q.19** Expressing $0.\overline{23} + 0.\overline{23}$ of a single decimal, we get -
 (A) $0.\overline{465}$ (B) $0.\overline{465}$
 (C) $0.\overline{465}$ (D) $0.\overline{4654}$
- Q.20** The value of $\left[\sqrt[3]{6\sqrt{a^9}}\right]^4 \left[\sqrt[6]{3\sqrt{a^9}}\right]^4$ is :
 (A) a^{16} (B) a^{12} (C) a^8 (D) a^4
- Q.21** If $a = \frac{9}{\sqrt{11} - \sqrt{2}}$; $b = \frac{6}{3\sqrt{3}}$, then the relation between a and b is -
 (A) $a < b$ (B) $a > b$
 (C) $a + b < 1$ (D) $a = b$
- Q.22** Value of $\frac{2^{100}}{2}$ is -
 (A) 1 (B) 50^{100}
 (C) 2^{50} (D) 2^{99}
- Q.23** Which is the greatest number amongst $2^{1/2}$, $3^{1/3}$, $8^{1/8}$ and $9^{1/9}$?
 (A) $9^{1/9}$ (B) $8^{1/8}$ (C) $3^{1/3}$ (D) $2^{1/2}$
- Q.24** If $N = \frac{\sqrt{\sqrt{5+2}} + \sqrt{\sqrt{5-2}}}{\sqrt{\sqrt{5+2}}} - \sqrt{3-2\sqrt{2}}$ then the value of N is :
 (A) $2\sqrt{2} - 1$ (B) 2
 (C) 1 (D) $\sqrt{5} - \sqrt{2}$
- Q.25** If $x^{p^q} = (x^p)^q$, then $p =$
 (A) $\frac{1}{q^q}$ (B) 1 (C) q^q (D) $q^{\frac{1}{q-1}}$
- Q.26** If in $\sqrt{3} + \sqrt[3]{5}$, $x = \sqrt{3}$ and $y = \sqrt[3]{5}$, then its rationalising factor is -
 (A) $x + y$
 (B) $x - y$
 (C) $x^5 + x^4y + x^3y^2 + x^2y^3 + xy^4 + y^5$
 (D) $x^5 - x^4y + x^3y^2 - x^2y^3 + xy^4 - y^5$
- Q.27** Of the following four numbers the largest is :
 (A) 3^{210} (B) 7^{140}
 (C) $(17)^{105}$ (D) $(31)^{84}$
- Q.28** The value of $\frac{2(\sqrt{2} + \sqrt{6})}{3\sqrt{2} + \sqrt{3}} + \sqrt{2 + \sqrt{3}} + \sqrt{2 - \sqrt{3}}$ is
 (A) $\frac{3 + 4\sqrt{6}}{3}$ (B) $\frac{4 + 3\sqrt{6}}{3}$
 (C) $\frac{3 + 4\sqrt{6}}{4}$ (D) $\frac{4 - 3\sqrt{6}}{3}$
- Q.29** The rationalizing factor of $\sqrt[n]{\frac{a}{b}}$ is
 (A) $ab\sqrt[n]{\frac{a}{b}}$ (B) $\sqrt[n]{\frac{a}{b}}$
 (C) $\sqrt[n]{\frac{a^{n-1}}{b^{n-1}}}$ (D) $\sqrt[n]{\frac{a^{n+1}}{b^{n+1}}}$
- Q.30** Value of the expression :
 $\frac{1}{\sqrt{11-2\sqrt{30}}} - \frac{3}{\sqrt{7-2\sqrt{10}}} - \frac{4}{\sqrt{8+4\sqrt{3}}}$
 (A) $\sqrt{30}$ (B) $2\sqrt{10}$
 (C) 1 (D) 0

- Q.47** Which is unit digit of $6^{18} - 5^{10}$?
(A) 5 (B) 8
(C) 1 (D) 9
- Q.48** Which of the following is not an irrational number ?
(A) $2 + \sqrt{5}$ (B) $\sqrt{2}$
(C) $\frac{7}{\sqrt{5}}$ (D) $\frac{2\sqrt{11}}{7\sqrt{11}}$
- Q.49** If G.C.D of two number is 8 and their product is 384, then their L.C.M is _____.
(A) 24 (B) 16
(C) 32 (D) 48
- Q.50** $317/3125$ represents
(A) A terminating decimal
(B) A non-recurring decimal
(C) A recurring decimal
(D) An integer

ANSWER KEY

EXERCISE - 1

1. (i) Rational (ii) Rational (iii) Irrational (iv) Rational (v) Rational (vi) Irrational
 (vii) Irrational (viii) Irrational (ix) Irrational (x) Irrational
4. 1679 5. 43 6. $\sqrt{12}$, $(108)^{1/4}$ 7. $\sqrt{5}$, $(20)^{1/4}$ 8. No
11. (i) 0.115 (ii) 0.192 (iii) 0.053125 (iv) 0.21375 (v) 0.009375 (vi) 0.00608
12. (i) $\frac{8}{9}$ (ii) $\frac{22}{9}$ (iii) $\frac{8}{33}$ (iv) $\frac{11}{90}$ (v) $\frac{101}{45}$ (vi) $\frac{181}{495}$
13. (i) HCF = 18, LCM = 1584 (ii) HCF = 36, LCM = 11880 (iii) HCF = 128, LCM = 14976
 (iv) HCF = 1, LCM = 1260
14. 207 15. 12600 16. 7 m 17. 35 cm 18. 14 19. 9.6 m 20. 8 : 7 : 12 a.m.
21. 10 : 31 hrs 22. (i) 45 (ii) 36 (iii) 15 25. 814 26. 16 times
28. $x = -38$, $y = 13$ 29. (a) 2520 cm 30. (a) 17 l

EXERCISE - 2

Ques.	1	2	3	4	5	6	7	8	9	10	11	12	13	14	15	16	17	18	19	20
Ans.	C	B	C	D	C	B	D	B	A	D	C	B	B	B	A	C	D	A	C	C
Ques.	21	22	23	24	25	26	27	28	29	30	31	32	33	34	35	36	37	38	39	40
Ans.	A	C	D	D	D	B	B	B	D	D	C	B	D	D	D	A	B	D	A	A
Ques.	41	42	43	44	45	46	47	48	49											
Ans.	A	B	B	A	A	C	B	B	A											

EXERCISE - 3

Ques.	1	2	3	4	5	6	7	8	9	10	11	12	13	14	15	16	17	18	19	20
Ans.	A	B	C	A	B	C	B	B	A	C	D	B	D	B	C	D	A	D	B	D
Ques.	21	22	23	24	25	26	27	28	29	30	31	32	33	34	35	36	37	38	39	40
Ans.	B	D	C	D	D	D	C	B	C	D	C	D	C	D	C	B	C	B	A	C
Ques.	41	42	43	44	45	46	47	48	49	50										
Ans.	D	C	D	C	B	C	C	D	D	A										

SOLUTIONS

EXERCISE-1

➤ Very Short Answer Type Questions

Sol.1 (i) $\frac{22}{7}$ rational

(ii) 3.1416 rational

(iii) π Irrational

(iv) $\sqrt{21}$ Irrational

(v) $\sqrt[3]{3}$ Irrational

Sol.2 $\frac{a}{b} = \frac{1}{\sqrt{3}}$ (a, b are co-prime)

$3a^2 = b^2$

3 divide b^2

\therefore 3 divide b also

Now let

$b = 3c$

$3a^2 = 9c^2$

$a^2 = 3c^2$

3 divide b^2

\therefore divides a also

As both a & b has common factor 3

\therefore it is irrational

Sol.3 For any 2 +ve integer a & b there exist a unique +ve integer q & r such that

$a = bq + r$ where

$0 \leq r < b$

Sol.4 $a = bq + r$

$a = 61 \times 27 + 32 = 1647 + 32$

$a = 1679$

Sol.5 $a = bq + r$

$1365 = b(31) + 32$

$$\frac{1365 - 32}{31} = b$$

$b = 43$

➤ Short Answer Type Questions – Type I

Sol.6 Rational no are

$$\frac{3+4}{2} = \frac{7}{2} = 3.5 \Rightarrow \frac{3.5+4}{2} = \frac{7.5}{2} = 3.25$$

Irr. no. $\frac{10}{3} = 3.33 \Rightarrow \frac{11}{3} = 3.66$

Sol.7 An irrational no b/w 2 & 2.5

I $\rightarrow \sqrt{2 \times 2.5} = \sqrt{5}$

II $\rightarrow \sqrt{2\sqrt{5}}$

Sol.8 $6^n =$

There is no natural no such 6^n is divide by 7.

Sol.9 (i) $\sqrt{16}$ Irrational

(ii) $2 - \sqrt{3}$
 $\downarrow \quad \downarrow \quad \Rightarrow$ Irrational
 Rational Irrational

(iii) $(5 - 3\sqrt{2})$
 $\downarrow \quad \downarrow \quad \Rightarrow$ Irrational
 Rational Irrational

Similarly remaining parts

Sol.10 (i) $\frac{11}{2^3 \cdot 3}$

(ii) $\frac{73}{7^3 \cdot 3^3 \cdot 5}$

(iii) $\frac{9}{35} = \frac{9}{5 \times 7}$

(iv) $\frac{32}{147} = \frac{32}{7 \times 21} = \frac{32}{7^2 \cdot 3}$

Similarly remaining parts

➤ Short Answer Type Questions – Type II

Sol.11 (i) $\frac{23}{2^3 5^2}$

(ii) $\frac{24}{125} = \frac{24}{5^3}$

(iii) $\frac{17}{320} = \frac{1}{2^6 \times 5}$

(iv) $\frac{171}{2 \times 2 \times 2 \times 2 \times 2 \times 5 \times 5} = \frac{171}{2^5 \times 5^2}$

(v) $\frac{15}{1600}$

Similarly remaining parts

Sol.12 $x = 0.888$ (1)
 $10x = 8.888$ (2)
 Eq. (2) – (1)
 $9x = 8.000$
 $x = \frac{8}{9}$

Sol.13 (i)

$$\begin{array}{r|l} 2 & 144, 198 \\ 3 & 725, 99 \\ 3 & 24, 33 \\ 8 & 8, 11 \\ 11 & 1, 11 \\ \hline & 1 \end{array}$$

$2^4 \times 3^2 \times 11 = \text{L.C.M.}$

(iv)

$$\begin{array}{r|l} 3 & 21, 28, 36, 45 \\ 2 & 7, 28, 12, 15 \\ 3 & 7, 14, 6, 15 \\ 2 & 7, 14, 2, 5 \\ 5 & 7, 7, 1, 5 \\ 7 & 7, 7, 1, 1 \\ \hline & 1 \ 1 \ 1 \ 1 \end{array}$$

$3^2 \times 2^2 \times 5 \times 7 = \text{L.C.M.}$

$$\begin{array}{r} 504 \overline{)1188} \left(\begin{array}{l} 2 \\ 1008 \end{array} \right) \\ \hline 18 \overline{)504} \left(\begin{array}{l} 2 \\ 360 \end{array} \right) \\ \hline 144 \overline{)180} \left(\begin{array}{l} 1 \\ 144 \end{array} \right) \\ \hline 36 \overline{)144} \left(\begin{array}{l} 2 \\ 72 \\ 56 \end{array} \right) \\ \hline 68 \overline{)144} \left(\begin{array}{l} 2 \\ 126 \\ 18 \end{array} \right) \\ \hline 18 \overline{)28} \left(\begin{array}{l} 1 \\ 18 \\ 54 \\ 18 \end{array} \right) \end{array}$$

Similarly remaining parts

Sol.14 $\text{H.C.F.} \times \text{L.C.M} = a \times b$
 $23 \times 1449 = 161 \times b$
 $\frac{23 \times 1449}{161} = b$
 $107 = b$

Sol.15 $\text{H.C.F} \times \text{L.C.M} = a \times b$
 $= 105 \times 120 = 12600$

Sol.16 $42 = 7 \times 6$
 $49 = 7 \times 7$
 $63 = 7 \times 9$
 H.C.F. = 7

Sol.17 700 cm
 385 cm
 1295 cm
 $700 = 7 \times 100 = 7 \times 25 \times 4 = 7 \times 5 \times 5 \times 4$
 $385 = 77 \times 5 = 35 \times 11 = 7 \times 5 \times 11$
 $1295 = 259 \times 5 = 7 \times 5 \times 51$
 HCF = 35

Sol.18 H.C.F OF (336, 240, 96)
 $336 = 14 \times 24 = 2 \times 7 \times 2 \times 2 \times 3 \times 2$
 $240 = 24 \times 10 = 2 \times 2 \times 2 \times 3 \times 2 \times 5$
 $96 = 24 \times 4 = 2 \times 2 \times 2 \times 3 \times 2 \times 2$
 HCF = $2 \times 2 \times 2 \times 2 \times 3 = 48$

Sol.19 LCM (64, 80, 96)
 $64 = 2 \times 2 \times 2 \times 2 \times 2 \times 2$
 $80 = 2 \times 2 \times 2 \times 2 \times 5$
 $96 = 2 \times 2 \times 2 \times 2 \times 2 \times 3$
 LCM = $2^6 \times 3 \times 5$
 $= 960 \text{ cm} = 9.6 \text{ m}$

Sol.20 LCM of 48, 72, 108
 $= 2 \times 2 \times 2 \times 2 \times 3 \times 3 \times 3$
 $= 432 \text{ sec}$
 After 432 seconds, the lights charge simultaneously

➤ Long Answer Type Questions

Sol.21 LCM of 60 & 62 will give the time at which both devices beep at same after 10 am
 $\text{LCM } 60 \ \& \ 62 = 2 \times 30 \times 31$
 $= 1860 \text{ s}$
 Time at which both device beep at same time after 10 am = $\frac{1860}{60} = 31 \text{ min}$
 time = 10 : 31 am

Sol.22

$$\begin{array}{r} 6 \\ 405 \overline{)2520} \left(\begin{array}{l} 6 \\ 2430 \end{array} \right) \\ \hline 90 \overline{)405} \left(\begin{array}{l} 4 \\ 360 \end{array} \right) \\ \hline 45 \overline{)90} \left(\begin{array}{l} 2 \\ 90 \end{array} \right) \\ \hline 45 \end{array}$$

HCF = 45
 Similarly for (ii) & (iii)

Sol.23 By euclid div. algorithm
 $a = bq + r$
 $a = 6q + r$
 $r = 0$ $a = 6q$
 $r = 1$ $a = 6q + 1$
 $r = 2$ $a = 6q + 2$

Sol.2 $n^2 < 8n < 35n < n^3$
 $n = 5$
 $25 < 40 < 175 < 125$ Not True
 $n = 6$
 $36 < 48 < 210 < 216$ True
 $n = 7$
 $49 < 56 < 245 < 343$ True
 $n = 8$
 $64 < 64 < 280 < 512$ Not True
 Only $n = 7, n = 8$ Satisfy.

Sol.3 The sequence
 o. $xy \ xy \ xy \ \dots$ can be written as
 $= (xy \div 100) + (xy \div 10,000) + \dots$
 $= (xy \div 100) + (1 + 1 \div 100 + 1 \div 10,000 + \dots)$
 (The IIIrd part is a Geometric series with
 ration $1/100$)
 $= (xy \div 100) \times 1 \div (1 - 1 \div 100) = xy \div 99$
 as $xy \div ab = 0.xy \ xy \ xy \ \dots = xy \div 99$
 ab is 99

Sol.4 (A) Given a, b is even
 Let $a=2\lambda_1, \lambda_1, \lambda_2 \in \mathbb{I}$
 $b=2\lambda_2$
 $c=\lambda_3+1, \lambda_3, \lambda_4 \in \mathbb{I}$
 $d=2\lambda_4+1$

(A) $a^2-b^2+c^2-d^2$
 $(a-b)(a+b)+(c-d)(c+d)$
 $2(\lambda_1-\lambda_2) 2(\lambda_1+\lambda_2) + 2(\lambda_3+\lambda_4) 2(\lambda_3+\lambda_4+1)$
 $4(\text{Integer}) + 4(\text{Integer})$
 $4(\text{Integer})$ So divided by 4 T

(B) $abc + bcd + cda + dab$
 $100a + 10b+c + 100b+10c+d + 100c + 10d +$
 $a + 100d ++ 10a + b$
 $100(a+b+c+d) + 10(b+c+d+a) + (a+b+c+d)$
 $(a+b+c+d)(100+10+1)$
 $(a+b+c+d) 111$

(C) $a^4 + b^4 + c^3 + d^3 + b(a^2+c^2)$
 $\downarrow \quad \downarrow \quad \downarrow \quad \downarrow \quad \downarrow$
even even odd odd + even
 Even + odd \Rightarrow odd always

(D) $a+2b+3c+4d$
 $2\lambda_1+4\lambda_2+6\lambda_3+3+8\lambda_4+4$
 $(2\lambda_1+4\lambda_2+6\lambda_3+8\lambda_4) + \frac{7}{\text{odd}}$ odd even

Sol.5 a, a+2, a+4 is prime
 $a=3$
 3, 5, 7

Sol.6 Let x, y, z w are 4 prime no
 $XYZ = 385, \quad YZW = 1001$

5	385
7	77
11	11
	1

7	1001
11	143
13	13
	1

$X = 5$
 $Y = 7$
 $Z = 11$
 $W = 13$
 Last = 13

Sol.7 2 or 6 or 8

Sol.8 $(n-1).(n-2).....3.2.1$
 Put $12 \leq n \leq 40$
 as $n = 12, 13, 14 \dots 40$
 i.e. 7

Sol.9 $m = 3\lambda_1$
 $n = 7\lambda_2$
 $m + n = 3\lambda_1 + 7\lambda_2$
 Since $7 + 3 = 10$
 The least prime factor of $a + b$ has to be
 2 : unless $a + b$ is a prime no greater than 2.

Sol.10 Put $a = v + 1$ we get
 $v + 2, v + 3, v + 4 \dots, v + 41$
 $A+1, A+2, A+4, A+5 \dots A+40$
 So no of prime is zero
 Because each pair is complete
 So each given no is of form $v + k$
 k is one of first 41 natural no & $k \neq 1$
 we know v is divisible by any of the first 41
 natural no.
 None since a given no is $v + k$ & v is
 divisible by any of the k s, then $v + k$ must
 be divisible by k .
 \therefore No given number must be a prime

Sol.11 $5^{84} \cdot 2^{84} \cdot 2^2$
 $(10)^{84} \cdot 4$
 $4(100000 \dots 0)$
 84 digit

Sol.12 $\frac{1}{5} = \frac{1}{n} + \frac{1}{m}$
 $\frac{1}{5} = \frac{m+n}{mn}$
 $mn = 5m + 5n$
 $2mn = 10m + 10n$
 $10m - mn + 10n - mn = 0$
 $m(10-n) - n(10-n) = 0$
 $(10-n)(m-n) = 0$

Sol.13 $a^2 - b^2 = 13$
 $(a-b)(a+b) = 13$
 $(a-b)(a+b) = 13 \times 1$
 $a - b = 13$ $a + b = 13$
 $a + b = 1$ $a - b = 1$
 $\frac{2a = 14}{a = 7}$ $\frac{2a = 14}{a = 7}$
 $b = -6$ } Not pass $b = 6$

Sol.14 $27.3^8.5^9$
Number of divisor = $(7+1)(8+1)(9+1)$
= $8 \times 9 \times 10$
= 720

Sol.15 LCM of no 15, 25 & 35 will be $75 \times 7 = 525$
The no has a remainder of 25 when divided by 35
Similarly no. has remainder 15 on dividing by 25 & rem = 5
when divided by 15.
In each of case we are 10 short of getting a zero remainder.
So the desired no must be = $525 - 10 = 515$

Sol.16 HCF . LCM = p.q
 $12 \times \text{LCM} = 1800$
 $\text{LCM} = \frac{1800}{12}$
LCM = 150

Sol.17 $l = 1517$ cm
 $b = 902$ cm
HCF of 1517 & 902 is 41.
area = $41 \times 41 = 1681$
No of tiles = $\frac{1517 \times 902}{1681}$
= 814

Sol.18 LCM of 6, 12, 15, 18 is 180
Hence watches will ring simultaneously after every 180 sec
ie. after every 3 minutes
In 4 hours ($4 \times 60 = 240$ minutes)
The watches will ring simultaneously for 80 minute.
Including the simultaneously ring at the start, the watches will ring for 81 times.
(4 hr = $4 \times 60 = 240$ min
240 min = $240 \times 60 = 14400$ sec.
 $n = 14400/180 + 1 = 81$ time)

Sol.19 $4^{25} + 5^{15}$ is divided by 10
 $\frac{4^{25} + 5^{15}}{10} \Rightarrow \frac{2^{50} + 5^{15}}{10} = \text{Remainder}$

Sol.20 $N = 2345631143a4$
 $36+a$ is divided by 3
 $a = 0$
 $a = 3$
 $a = 6$
 $a = 9$
4 value

Sol.21 $1^{13} + 2^{13} + 3^{13} + \dots + 60^{13}$ divided
 $(1^{13} + 60^{13}) + (2^{13} + 59^{13}) + \dots + (30^{13} + 31^{13})$
However, 13 is odd
 $(60 + 1)$ divides $(60^{13} + 1^{13})$
 $(59 + 2)$ divides $(59^{13} + 2^{13})$ & so on
Hence, 61 divides the sum.....

Sol.22
 d 456d is divided by 18
 $\begin{matrix} & d & \\ / & & \backslash \\ 6 & & 3 \end{matrix}$
 $15 + 2d$ is divided by 3
 $d \neq 0$
 $d = 3$

Sol.23 $\frac{7}{x}$ is integer
 $x = 1$
 $x = -1$
 $-x = 7$
 $x = -7$

Sol.24 $19^n - 1^n$
 $(19 - 1)(\quad)$
 $18(\mathbb{Z})$ (\mathbb{Z} is integer)

Sol.25 $N = 2^{30} - 1$
= $(2^{15})^2 - (1)$
= $(2^{15} - 1)(2^{15} + 1)$
= $((2^5)^3 - 1^3)(2^{15} + 1)$
= $(2^5 - 1)((2^5)^2 + 1 - 2^5) \dots \dots \dots$

Sol.26 $35 = 5 \times 7$
 $45 = 3 \times 3 \times 5$
 $55 = 5 \times 11$
LCM = $3 \times 3 \times 5 \times 7 \times 11 = 3465$
∴ difference between division & remainder is 10
Hence least no is $3465 - 10 = 3455$

Sol.27 $4^{101} + 6^{101}$
 $(5 - 1)^{101} + (5 + 1)^{101}$
 $2 \left\{ \frac{{}^{101}C_0 5^{101} + {}^{101}C_2 5^{99} + \dots + {}^{101}C_{99} 5^2}{25} \right\} + \frac{{}^{101}C_{100}}{25}$

$$0 + \frac{{}^{101}C_1 \cdot 5 \cdot 2}{25}$$

$$\frac{101 \cdot 5 \cdot 2}{25} \Rightarrow \frac{202}{5}$$

Sol.28 $\frac{13^{400}}{11}$

$$\frac{(11+2)^{400}}{11} = \frac{(2)^{400}}{11}$$

$$= (2^5)^{80} = \frac{(33-1)^{80}}{11} \Rightarrow \frac{1}{11}$$

Reminder = 1

Sol.29 $f(x) = 5 - |x - 3|$

When $x \geq 3$

$$f(x) = 5 - x + 3 = 8 - x$$

Thus, maximum value will be when x is least $x = 3$

Hence $f(x) = 5$

When $x < 3$

$$f(x) = 5 + x - 3 = 2 + x$$

Thus $f(x)$ is maximum when x is maximum or $x = 3$

Hence $f(x) = 5$

Sol.30 $|1 - |1+x||$

$$|1+1+x|$$

$$|x+2|$$

$x < -2$ $-(x+2)$

$$-(x+2)$$

Sol.31 $\log_{10} 2 = 0.30103, \log_{10} 3 = 0.47712$

$$x = 3^{12} \cdot 2^8$$

$$\log x = 12 \cdot \log_{10} 3 + 8 \cdot \log_{10} 2 = 12.$$

Sol.32 $\log_3 4 \cdot \log_4 5 \cdot \log_5 6 \cdot \log_6 7 \cdot \log_7 8 \cdot \log_8 9$

$$\frac{\log 94}{\log 93} \cdot \frac{\log 95}{\log 94} \cdot \frac{\log 96}{\log 95} \cdot \frac{\log 97}{\log 96} \cdot \frac{\log 98}{\log 97} \cdot \frac{\log 99}{\log 98}$$

$$\frac{\log 93^2}{\log 93} = \frac{2 \log 93}{\log 93} = 2$$

Sol.33 $81^{\frac{1}{\log_5 3}} + 27^{\log_9 36} + 3^{\frac{4}{\log_7 9}}$

$$81^{\log_3 5} + (3)^{3 \cdot \log_{3^2} (6)^2} + 3^{4 \log_9 7}$$

$$81^{\log_3 5} + (3^3)^{3 \cdot \log_3 6} + 3^{\frac{4}{2} \log_3 7}$$

$$3^{4 \log_3 5} + 3^{3 \cdot \log_3 6} + 3^{2 \log_3 7}$$

$$3^{\log_3 5^4} + 3^{\log_3 6^3} + 3^{\log_3 7^2}$$

$$5^4 + 6^3 + 7^2 = 890$$

Sol.34 $\log_4 5 = a, \log_3 6 = b \Rightarrow \log_3 2$

$$= \frac{1}{\log_2 3}$$

$$= \frac{2}{2.2 \log_2 3}$$

$$= \frac{2}{4 \log_4 3}$$

Sol.35 $\log_{10} p + \log_{10} q = \log_{10} (p-q)$

$$\log_{10} pq = \log_{10} (p-q)$$

$$pq = p - q$$

$$pq + q = p$$

$$q(p+1) = p$$

$$q = \frac{p}{p+1} \Rightarrow \frac{q}{1-q} = p$$

Sol.36 $10^{999} 10^{999}$

$$((10)^3)^{333}$$

$$(1000)^{333}$$

Sol.37 $E_2(L150) = \left[\frac{150}{2} \right] + \left[\frac{150}{4} \right] + \left[\frac{150}{8} \right]$

$$+ \left[\frac{150}{16} \right] + \left[\frac{150}{32} \right] + \left[\frac{150}{64} \right] + \left[\frac{150}{128} \right]$$

$$= 75 + 37 + 18 + 9 + 4 + 2 + 1$$

Sol.38

$$X = 2(2(2\{(2(2x-1)-1)\}-1)-1)-1$$

$$= 2\{4x-2-1\}$$

$$= 2\{8x-6\}-1$$

$$= 2\{16x-12\}-1$$

$$= 32x-26-1$$

$$X = 32x-27-1$$

Sol.39 $\frac{1}{2} + \frac{2}{2^2} + \frac{2^2}{2^3} + \dots + \frac{2^{2006}}{2^{2007}} + \frac{2^{2007}}{2^{2006}}$

$$\frac{1}{2} + \frac{1}{2} + \frac{1}{2} + \dots$$

$$\left(\frac{1}{2} \right) \cdot 2008$$

$$1004$$

Sol.40 $\lfloor 6 \rfloor = \lfloor a \rfloor \times \lfloor b \rfloor$

$$6 \times 5 \times 4 \times 3 \times 2 \times 1$$

$$720$$

$$\lfloor 5 \rfloor \times \lfloor 3 \rfloor$$

$$\begin{aligned} a &= 5 \\ b &= 3 \\ a + b &= 8 \end{aligned}$$

Sol.41 ATQ

$$\begin{aligned} d + 0 &= 1 \Rightarrow d = 1 \\ c + d &= 0 \Rightarrow c = -1 \\ b + c &= d \Rightarrow b = d - c \\ a + b &= c \Rightarrow a = c - d \\ &= -1 - 1 = -2 \\ \therefore a &= -3 \end{aligned}$$

Sol.42 $\left(1 - \frac{1}{3}\right)^2 \left(1 - \frac{1}{4}\right)^2 \left(1 - \frac{1}{5}\right)^2 \dots \left(1 - \frac{1}{n}\right)^2$

$$\frac{2^2}{3^2} \cdot \frac{3^2}{4^2} \cdot \frac{4^2}{5^2} + \dots + \frac{(n-1)^2}{n^2}$$

$$\left(\frac{2}{n}\right)^2$$

Sol.43

$$\begin{aligned} &\sqrt{\sqrt{2}-1 + \sqrt{3}-\sqrt{2} + \sqrt{4}-\sqrt{3} + \dots + \sqrt{99} + \sqrt{100}} \\ &= \sqrt{10-1} \\ &= \sqrt{9} \\ &= 3 \end{aligned}$$

Sol.44 Let

$$\begin{aligned} x &= \sqrt[3]{2+\sqrt{5}} + \sqrt[3]{2-\sqrt{5}} \\ x^3 &= 2 + \sqrt{5} + 2 - \sqrt{5} + 3x \\ x^3 &= 4 - 3x \\ x^3 + 3x - 4 &= 0 \\ x &= 1 \end{aligned}$$

Sol.45 1

Sol.46 $\sqrt{9-(n-2)^2} \in \mathbb{R}$

Positive

$$\begin{aligned} 9 - (n-2)^2 &\geq 0 \\ (n-2)^2 - 9 &\leq 0 \\ (n-2)^2 - 3^2 &\leq 0 \\ (n-2-3)(n-2+3) &\leq 0 \\ (n-5)(n+1) &\leq 0 \end{aligned}$$

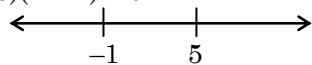

$$\begin{aligned} n &\in [-1, 5] \\ n &= -1, 0, 1, 2, 3, 4, 5 \\ \therefore n &= 7 \end{aligned}$$

Sol.47 Let $\sqrt{1+2+3+4+5+x} = l$

$$\begin{aligned} \sqrt{10+x} &= l \quad (l \text{ is an +ve integer}) \\ x &= l^2 - 10 \\ \text{Given } l &< x < 100 \\ 1 &< l^2 - 10 < 100 \\ 11 &< l^2 < 110 \\ \sqrt{11} &< l < \sqrt{110} \\ 3.32 &< l < 10.49 \\ l &= 4, 5, 6, 7, 8, 9, 10 \\ \therefore &\text{ there are 7 values of } x \end{aligned}$$

Sol.48 Let $A^{1/A} = B^{1/B} = C^{1/C} = x$

Taking power ABC each

$$A^{BC} + B^{AC} + C^{AB} = x^{ABC}$$

Now $A^{BC} + B^{AC} + C^{AB} = 729$

$$\begin{aligned} 3x &= 729 \\ x &= 243 \end{aligned}$$

Sol.49 $\frac{x^2-1}{x^{2009}} = \frac{x^{2010}}{x^{2009}} = x$

EXERCISE-3

Sol.1 $\left(\frac{1}{a}\right)^b = \bar{3}$

Let $x = 0.3333 \dots \dots (1)$

$10x = 3.333 \dots \dots (2)$

$9x = 3 \quad (2) - (1)$

$x = \frac{1}{3}$

$\left(\frac{1}{a}\right)^b = \left(\frac{1}{3}\right)^1$

$\left(\frac{1}{a}\right)^b = \left(\frac{1}{27}\right)^{\frac{1}{3}}$

$a = 27$

$b = 3$

$ab = 27.3$

$= 81$

Sol.2 $10^n \equiv n + 1$

i.e. 10, 100, 1000

$10^n - 1 \equiv n$ times 9 i.e. 9, 99, 999

\therefore sum of digits = $9 + 9 + \dots + 9 = 9n$

$9n = 4707$

$n = 523$

Sol.3 $\left(\frac{5x+7}{x}\right)\left(\frac{13y+1}{13}\right) = 12$

$5x + 7 = 13N$ (1)

& $13y + 1 = xM$ (2)

$\frac{13N}{x} \times \frac{xM}{13} = 12$

$NM = 12$

M & N is 4 or 3

$n = 4$ in (1)

$5x + 7 = 13 \times 4 = 52$

$5x = 45$

$x = 9$

Put $x = 9$ in (2)

$13y + 1 = xM$

$13y + 1 = 9 \times 3$

$13y = 27 - 1 = 26$

$y = 2$

$\therefore x - y = 9 - 2 = 7$

Sol.4 $1x . 3y 6$ five digit number

and $y = x + 6$

$1x . 3(x + 6).6$

$16 + 2x =$

$x = 1$

$y = 7$

$\frac{1}{7}$

$\frac{y}{x} = \frac{1}{7}$

Sol.5 Let nos. be

a, b, c

b is perfect cube

let b = 8, 27, 64, 125

ie. $2^3, 3^3, 4^3, 5^3$

$a + b + c = 200$

$b \neq 1$

\therefore Total value possible 4

Sol.6 $xyz = 100x + 10y + z$ (1)

$zyx = 100z + 10y + x$ (2)

Eq. (1) - (2)

$99x - 99z = 297$

$x - z = 3$ (3)

$x = z + 3$

$x + y + z = 8$ (4)

$z + 3 + y + z = 8$

$y + 2z = 5$

y	z	x
---	---	---

5	0	3
3	1	4
1	2	5

$x > (y, z)$

$xyz \rightarrow 431 \rightarrow 134$ or 512

difference = 297

$xyz = 431, 512$

10's digit is 1 or 3

Sol.7

$5 \times 10 \times 25 \times 40 \times 50 \times 55 \times 65 \times 125 \times 80$
 $\downarrow \quad \downarrow \quad \downarrow \quad \downarrow \quad \downarrow \quad \downarrow \quad \downarrow \quad \downarrow \quad \downarrow$
 $5 \ (5.2) \ (5.5) \ (2^3.5) \ (5^2, 10) \ (5^1, 11) \ (5, 13) \ (5) \ (2^4.5)$

$2^9 \times 5^{13} \times 11 \times 13$

$(2 \times 5)^9 \times 5^4 \times 11 \times 13$

$10^9 \times 5^4 \times 11 \times 13$

zeros = 9

Sol.8 Herd = x

$\frac{x}{2} \quad \frac{x}{4} \quad \frac{x}{5} \quad 7$

$\frac{x}{2} + \frac{x}{4} + \frac{x}{5} = \frac{19x}{20}$

Remaining cows = $x - \frac{19x}{20} = \frac{x}{20}$

$\frac{x}{20} = 7$

$x = 140$

Sol.9 $\log_{12} 27 = a$

$\text{Log}_6 16 = \frac{\log 16}{\log 6}$

$4 \left(\frac{3-a}{3+a} \right)$

$4 \left(\frac{3 - \log_{12} 27}{3 + \log_{12} 27} \right)$

$4 \frac{(\log_3 27 - \log_{12} 27)}{(3 + \log_{12} 27)}$

$\frac{\log 27}{\log 4 \times 3} = a$

$\frac{3 \log 3}{2 \log_2 + \log_3} = a$

Now $\log_6 16 = \frac{\log 2^4}{\log 2 + \log 3}$

$= \frac{4}{1 + \frac{\log_3}{\log_2}}$

Sol.10 $\log\left(\frac{24}{25}\right)^4 - \log\left(\frac{9}{10}\right)^{16} + \log\left(\frac{81}{80}\right)^7$
 $\log\left(\frac{\left(\frac{24}{25}\right)^4 \times \left(\frac{81}{80}\right)^7}{\left(\frac{9}{10}\right)^{16}}\right) = \log 5$

$x = \frac{34}{99}$
 $y = .344444$
 $10y = 3.44444$
 $100y = 34.3444$
 $99y = 34$
 $y = \frac{34}{99}$

Sol.11 $\sqrt[3]{9} = 9^{1/3}$

Sol.12 $\text{LCM} \times \text{HCF} = a \times b$
 $225 \times 15 = a \times b$
 $a \times b = 15 \times 15 \times 15$

Sol.13 HCF of two prime no is
HCF (a, b) = 1

Sol.14 The traffic light at
HCF (48, 72, 108)
 $48 = 16 \times 3 = 2 \times 2 \times 2 \times 2 \times 3$
 $72 = 12 \times 2 \times 3 = 2 \times 2 \times 3 \times 2 \times 3$
 $108 = 36 \times 3 = 2 \times 3 \times 2 \times 3 \times 3$
HCF = $2 \times 2 \times 3 = 12$

Sol.15 4663

$$\begin{array}{r} 17 \\ 520 \overline{)4680(9} \\ \underline{4680} \\ 0 \end{array}$$

Sol.16 $\frac{(1+\sqrt{3})^3 - (1-\sqrt{3})^3}{\sqrt{3}}$
 $= \frac{(1+3\sqrt{3}+3\sqrt{3}+9) - (1-3\sqrt{3}-3\sqrt{3}+9)}{\sqrt{3}}$
 $= \frac{6\sqrt{3}+6\sqrt{3}}{\sqrt{3}} = \frac{12\sqrt{3}}{\sqrt{3}} = 12$

Sol.17

$$13 \overline{) \frac{x}{3}} ($$

$$21 \overline{) \frac{x}{11}} ($$

If no is lying between 500 – 600

Sol.18 $x = \overline{.34}$
 $x = .343434$
 $100x = 34.3434$
 $99x = 34$

Sol.19 $x = .232323$
 $100x = 23.2323$
 $y = .2333333$
 $100y = 23.2323$
 $99y = 23$
 $y = \frac{23}{99} = .46\overline{5}$

Sol.20 $\left[\sqrt[3]{6\sqrt{a^9}}\right]^4 \left[\sqrt[6]{3\sqrt{a^9}}\right]^4$
 $((a^{3/2})^{1/3})^4 (a^{3/6})^4$
 $a^2 \cdot a^2 = a^4$

Sol.21 $a = \frac{9}{\sqrt{11}-\sqrt{2}}, b = \frac{6}{3\sqrt{3}}$
 $a = \frac{9(\sqrt{11}+\sqrt{2})}{9} \Rightarrow b = 2$
 $a > b$

Sol.22 $\frac{2^{100}}{2}$
 2^{99}

Sol.23
 $2^{1/2}, 3^{1/3}, 8^{1/8}, 9^{1/9}$
 $((2)^{1/2})^{72}, (3^{1/3})^{72}, (8^{1/8})^{72}, (9^{1/9})^{72}$
 $2^{36}, 3^{24}, 8^9, 9^8$
 $2^{36}, 3^{24}, 2^{27}, 3^{16}$
 $2^{1/2}, 3^{1/3}$
 $(2)^3, (3)^2$
 $8, 9$
 $3^{1/3}$ is largest

Sol.24 $N = \frac{\sqrt{\sqrt{5}+2} + \sqrt{\sqrt{5}-2}}{\sqrt{\sqrt{5}+2}} - \sqrt{3-2\sqrt{2}}$
 $\sqrt{5} - \sqrt{2}$

Sol.25 $x^{p^q} = x^{p^q}$
 $p^q = pq$
 $p^{q-1} = q$
 $p = (q)^{1/q-1}$

Sol.26 $x = \sqrt{3}, y = \sqrt[3]{5}$
 $(x + y)$
 $x^5 - x^4y + x^3y^2 - x^2x^3 + xy^4 - y^5$

Sol.27 Here
 3^{210}
 7^{140}
 $(17)^{105}$
 $(31)^{84}$
 $(17)^{105}$

Sol.28 $\frac{2(\sqrt{2} + \sqrt{6})}{3\sqrt{2 + \sqrt{3}}} + \sqrt{2 + \sqrt{3}} + \sqrt{2 - \sqrt{3}}$
 $\frac{2(\sqrt{2} + \sqrt{6}) + 2 + \sqrt{3} + 1}{3\sqrt{2 + \sqrt{3}}}$
 $\frac{2\sqrt{2} + 2\sqrt{6} + 3 + \sqrt{3}}{3\sqrt{2 + \sqrt{3}}}$

Sol.29 $\left(\frac{a}{b}\right)^{1/n} \cdot \left(\frac{a^{n-1}}{b^{n-1}}\right)^{1/n}$
 $\frac{a^{\frac{1+n-1}{n}}}{b^{\frac{1+n-1}{n}}} = \frac{a^{\frac{1+n-1}{n}}}{b^{\frac{1+n-1}{n}}}$
 $\frac{a}{b}$

Sol.30 Rationalise we get result 0

Sol.31 $\left(\frac{x^b}{x^c}\right)^{\frac{1}{bc}} \cdot \left(\frac{x^c}{x^a}\right)^{\frac{1}{ca}} \cdot \left(\frac{x^a}{x^b}\right)^{\frac{1}{ab}}$
 $\frac{b}{x^{bc}} \cdot \frac{c}{bc} \cdot \frac{c}{ca} \cdot \frac{a}{ac} + \frac{a}{ab} \cdot \frac{b}{ab} \Rightarrow \frac{1}{x^c} \cdot \frac{1}{b} \cdot \frac{1}{a} \cdot \frac{1}{c} \cdot \frac{1}{b} \cdot \frac{1}{a}$
 $x^0 = 1$

Sol.32 $3^{2x-y} = 3^{3/2}$
 $2x - y = 3/2$
 $x + y = 3/2$
 $3x = 6/2$
 $x = 1$
 $y = 1/2$
 $3^{x-y} = 3^{1-1/2} = 3^{1/2}$

Sol.33 $x = \sqrt{11\sqrt{11\sqrt{11}}}$
 $x = \sqrt{11x}$
 $x^2 - 11x = 0 \Rightarrow x(x - 11) = 0$
 $x = 0$
 $x = 11$

Sol.34 $\frac{1}{(\sqrt{2} - \sqrt{5}) - \sqrt{3}} + \frac{1}{(\sqrt{2} - \sqrt{5}) - \sqrt{3}}$
 $= \frac{\sqrt{2} - \sqrt{5} - \sqrt{3} + \sqrt{2} - \sqrt{5} + \sqrt{3}}{(\sqrt{2} - \sqrt{5})^2 - (\sqrt{3})^2}$
 $= \frac{2(\sqrt{2} - \sqrt{5})}{4 - 2\sqrt{10}} = \frac{1}{\sqrt{2}}$

Sol.35 $\sqrt[3]{12} > \sqrt{3} > \sqrt[6]{100}$

Sol.36 $2^m - 2^{m-1} - 4 = 0$
Let $2^m = t$
 $t - \frac{t}{2} - 4 = 0$
 $\frac{2t - t}{2} = 4$
 $t = 8$
 $2^m = 8$
 $2^m = 2^3$
 $m = 3$
 $3^3 = 27$

Sol.37 $ab = 21$
 $a - b = 4$
 $a = 7$
 $b = 3$
 $\frac{7^3 + 3^3}{7^3 - 3^3}$
 $\frac{10(49 + 9 + 21)}{4(49 + 9 - 21)} = \frac{185}{158}$

Sol.38 $a a b b$
 $1000a + 100a + 10b + b$
 $1100a + 11b = 11(100a + b)$
for $a a b b$ to be a perfect square
 $100a + b = 11 \times n^2$
Continue
 $aabb = 11 \times 11 \times n^2$
 $n = 1 \quad 11 \times 11 = 121$
 $n = 2 \quad 11 \times 44$
 $n = 3 \quad 11 \times 11 \times 9 = 121 \times 9 = 1089$
 $n = 4, 5, 6, 7, 9$
 $n = 8 = 11 \times 11 \times 64 = 7744$
 $\therefore a + b$
 $7 + 4 = 11$

Sol.39 Let odd consecutive
 no = $x - 2, x, x + 2$
 $200 < x - 2 + x + x + 2 < 400$
 $200 < 3x < 400$
 $225, 256, 289, 361, 324$
 $= 3, 5, 7$
 sum = $3 + 5 + 7 = 15$

Sol.40 (a) $75 = 1 + 25 + 49$
 (b) $250 = 225 + 25 = 15^2 + 5^2$
 $250 = 225 + 16 + 9$
 $= 15^2 + 4^2 + 3^2$

Sol.41 Let 2 no = x, y
 $x - y = 5$
 $x^2 - y^2 = 300$
 $(x - y)(x + y) = 300$
 $x + y = \frac{300}{5} = 60$

Sol.42 Let $a = 2\lambda + 1$
 Square of
 $a^2 = 4\lambda^2 + 1 + 4\lambda$
 $= 4(\lambda^2 + \lambda) + 1$
 $= 8n + 1$

Sol.43 $\sqrt{(a - b)^2} + \sqrt{(b - a)^2}$
 $|a - b| + |b - a|$
 If $a > b$
 $a - b - b + a$
 $2a - 2b$
 $2(a - b)$

Sol.44 $n^2 - 3n + 3$
 $n = 1$
 $n = 2$

Sol.45 $\sqrt{m^4 n^4} \times \sqrt[6]{m^2 n^2} \times \sqrt[3]{m^2 n^2} = (mn)^k$
 $(m^4 n^4)^{1/2} (m^2 n^2)^{1/6} (m^2 n^2)^{1/3} = (mn)^k$
 $(m^2 n^2)(mn)^{1/3} (m^{2/3} n^{2/3}) = (mn)^k$
 $(mn)^{2 + \frac{1}{3} + \frac{2}{3}} = (mn)^k$
 $(mn)^3 = (mn)^k$
 $k = 3$

Sol.46 $\frac{3 + 2\sqrt{3}}{3 - \sqrt{3}} = a + \sqrt{3} b$
 $\frac{(3 + 2\sqrt{3})(3 + \sqrt{3})}{(3 - \sqrt{3})(3 + \sqrt{3})} = a + \sqrt{3} b$

$$\frac{9 + 3\sqrt{3} + 6\sqrt{3} + 6}{9 - 3} = a + \sqrt{3} b$$

$$\frac{15 + 9\sqrt{3}}{6} = a + \sqrt{3} b$$

$$\frac{5}{2} + \frac{3}{2}\sqrt{3} = a + b\sqrt{3}$$

$$a = \frac{5}{2}, b = \frac{3}{2}$$

$$\sqrt{a + b} = \sqrt{\frac{5}{2} + \frac{3}{2}}$$

$$\sqrt{\frac{8}{2}} = \sqrt{4} = 2$$

Sol.47 $6^{18} \rightarrow \dots\dots\dots 6$
 $5^{10} \rightarrow \dots\dots\dots 5$
 $6 - 5 = 1$

Sol.48 $\frac{2\sqrt{11}}{7\sqrt{11}}$

Sol.49 LCM \times HCF = $a \times b$
 LCM $\times 8 = 384$
 LCM = $\frac{384}{8}$
 LCM = 48

Sol.50 $\frac{317}{3125}$
 $= \frac{317}{5^5}$
 Terminating decimal

NOTES

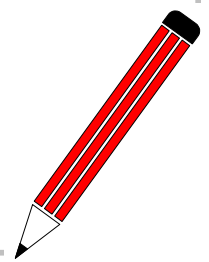

MENTAL ABILITY

LOGICAL SEQUENCE OF WORDS

In this type of question, some words are given. You have to arrange these words in a meaningful order. The order may be according to age, size and need etc..

Some common sequences have been discussed below :

◆ **TYPE –I : Sequence of occurrence of events or various stages in a process :**

Ex.1 Arrange the following in a meaningful sequence :

1. Leaf 2. Fruit 3. Stem
4. Root 5. Flower

- (A) 4, 3, 1, 5, 2 (B) 2, 3, 4, 1, 5
(C) 4, 3, 1, 2, 5 (D) 5, 1, 4, 3, 2

Sol. (A) Start from **root**, then **stem** will come out and then **leaf**, then **flower** and finally **fruit** will come..

Ex.2 Arrange the following in a logical order :

1. Birth 2. Death
3. Funeral 4. Marriage
5. Education

- (A) 1, 3, 4, 5, 2 (B) 1, 5, 4, 2, 3
(C) 2, 3, 4, 5, 1 (D) 4, 5, 3, 1, 2

Sol. (B) Clearly, the given words when arranged in the order of various events as they occur in a man's life, form the sequence : Birth, Education, Marriage, Death, Funeral.

◆ **TYPE –II : Sequence of objects in a class or group, from part to the whole :**

Ex.3 Arrange the following in a meaningful order, from particular to general:

1. Nation 2. Colony 3. City
4. District 5. State

- (A) 2, 3, 4, 5, 1 (B) 3, 1, 2, 5, 4
(C) 3, 1, 4, 2, 5 (D) 3, 1, 4, 5, 2

Sol. (A) Clearly, a **Colony** is a part of a **City**, which in turn is a part of **District** which is part of a **State** which lies within a **Country**.

Ex.4 Arrange the following in a logical order :

1. Shoulder 2. Wrist 3. Elbow
4. Palm 5. Finger

- (A) 2, 4, 5, 3, 1 (B) 3, 1, 4, 2, 5
(C) 3, 4, 5, 2, 1 (D) 5, 4, 2, 3, 1

Sol. (D) Clearly, we are given the names of parts of a hand, which may be arranged

(i) from top to bottom, i.e., **Shoulder, Elbow, Wrist, Palm, Finger**, which is 1, 3, 2, 4, 5; or

(ii) from bottom to top, i.e., **Finger, Palm, Wrist, Elbow, Shoulder**, which is 5, 4, 2, 3, 1.

Out of these, the sequence 5, 4, 2, 3, 1 is given in the alternatives provided.

◆ **TYPE –III : Sequence of increasing /decreasing size, value, intensity etc. :**

Ex.5 Arrange the following in a logical sequence from small to big :

1. Elephant 2. Cat 3. Mosquito
4. Tiger 5. Whale

- (A) 2, 3, 1, 4, 5 (B) 3, 2, 4, 1, 5
(C) 5, 1, 4, 2, 3 (D) 5, 4, 1, 2, 3

Sol. (C) Clearly, The **Whale** is the biggest then smaller than whale is **Elephant** then **Tiger** then **Cat** and then the smallest is **Mosquito**.

Ex.6 Arrange the following in a logical order :

1. Gold 2. Iron 3. Sand
4. Platinum 5. Diamond

- (A) 2, 4, 3, 5, 1 (B) 3, 2, 1, 4, 5
(C) 4, 5, 1, 3, 2 (D) 5, 4, 3, 2, 1

Sol. (B) Clearly, the given names when arranged in order of increasing values, i.e., from cheapest to the most expensive, form the sequence: **Sand, Iron, Gold, Platinum, Diamond**.

Thus, the correct answer is 3, 2, 1, 5, 4.

Ex.7 Arrange the following in a logical order :

- | | |
|----------------|--------------|
| 1. Euphoria | 2. Happiness |
| 3. Ambivalence | 4. Ecstasy |
| 5. Pleasure | |

- | | |
|-------------------|-------------------|
| (A) 1, 4, 2, 5, 3 | (B) 2, 1, 3, 4, 5 |
| (C) 3, 2, 5, 1, 4 | (D) 4, 1, 3, 2, 5 |

Sol. (C) All the given words stand for 'joy', but the intensity increases in the order - **Ambivalence, Happiness, Pleasure, Euphoria, Ecstasy.**

◆ **TYPE –IV : Sequence in which a chain of given objects is formed :**

Ex.8 Arrange the following in a meaningful sequence :

- | | |
|-----------|-------------|
| 1. Phrase | 2. Letter |
| 3. Word | 4. Sentence |

- | | |
|----------------|----------------|
| (A) 1, 2, 3, 4 | (B) 1, 3, 2, 4 |
| (C) 2, 3, 1, 4 | (D) 2, 3, 4, 1 |

Sol. (C) A group of **letters** makes a **word**. A group of **words** makes a **phrase**. A group of **phrases** makes a **sentence**.

Ex.9 Arrange the following in a meaningful sequence :

- | | |
|-----------|---------|
| 1. Grass | 2. Curd |
| 3. Milk | 4. Cow |
| 5. Butter | |

- | | |
|-------------------|-------------------|
| (A) 1, 2, 3, 4, 5 | (B) 2, 3, 4, 5, 1 |
| (C) 1, 4, 3, 2, 5 | (D) 5, 4, 3, 2, 1 |

Sol. (C) We know that cow eats grass and then gives milk. With the milk, curd is made and then from curd, butter is made.
Hence logical sequence is **Grass, Cow, Milk, Curd, Butter.**

EXERCISE

(Previous Year Questions - NTSE & NSO)

Directions : (Q.1 to Q.30) : In each of the following questions, arrange the given words in a meaningful sequence and then choose the most appropriate sequence from amongst the alternatives provided below each question :

- Q.1** 1. Skull 2. Shoulder
3. Neck 4. Face
5. Legs
(A) 1, 2, 3, 4, 5 (B) 1, 4, 3, 2, 5
(C) 1, 3, 4, 2, 5 (D) 1, 4, 2, 3, 5
- Q.2** 1. Sun 2. Planet
3. Galaxy 4. Stars
5. Moon
(A) 1, 3, 2, 5, 4 (B) 1, 3, 2, 4, 5
(C) 3, 1, 2, 5, 4 (D) 3, 4, 1, 2, 5
- Q.3** 1. Teacher 2. College
3. Guide 4. Study
5. Exam
(A) 2, 3, 1, 4, 5 (B) 2, 4, 1, 3, 5
(C) 4, 1, 2, 3, 5 (D) 2, 1, 3, 4, 5
- Q.4** 1. Animals 2. Cow
3. Vertebrates 4. Mammals
(A) 4, 1, 2, 3 (B) 1, 4, 2, 3
(C) 1, 3, 4, 2 (D) 4, 1, 2, 3
- Q.5** 1. Flat 2. Home
3. Building 4. Society
5. Place
(A) 5, 4, 3, 1, 2 (B) 5, 4, 3, 2, 1
(C) 4, 3, 1, 2, 5 (D) 4, 5, 3, 1, 2
- Q.6** 1. Sentence 2. Chapter
3. Letter 4. Book
5. Word 6. Paragraph
(A) 4, 2, 1, 6, 5, 3 (B) 4, 2, 6, 1, 5, 3
(C) 4, 6, 1, 2, 3, 5 (D) 4, 6, 2, 5, 1, 3
- Q.7** 1. Cut 2. Put on
3. Mark 4. Measure
5. Tailor
(A) 1, 3, 2, 4, 5 (B) 2, 4, 3, 1, 5
(C) 3, 1, 5, 4, 2 (D) 4, 3, 1, 5, 2

- Q.8** 1. Country 2. Furniture
3. Forest 4. Wood
5. Trees
(A) 1,3, 5, 4, 2 (B) 1,4,3,2,5
(C) 2,4,3,1,5 (D) 5,2,3,1,4

- Q.9** 1. Education 2. Job
3. Selection 4. Salary
5. Interview
(A) 1,3,5,2,4 (B) 1,5,3,2,4
(C) 1,2,3,5,4 (D) 1,5,2,4,3

- Q.10** 1. Child 2. Play 3. Game 4. Chess
5. Happy
(A) 1,3,2,4,5 (B) 1,2,3,4,5
(C) 1,3,4,2,5 (D) 5,1,2,3,4

- Q.11** 1. Index 2. Chapter
3. Book 4. Introduction
5. Questions
(A) 3,4,1,2,5 (B) 3,1,4,2,5
(C) 3,1,2,5,4 (D) 4,3,1,2,5

- Q.12** 1. Grain 2. Plant
3. Sandwich 4. Bread
5. Dough
(A) 1, 2, 5, 4, 3 (B) 2, 1, 4,5,3
(C) 2, 1, 5, 4, 3 (D) 2, 1, 4, 5, 3

- Q.13** 1. Andhra Pradesh 2. Universe
3. Tirupati 4. World
5. India
(A) 1, 5, 3, 2, 4 (B) 2, 1, 3, 5, 4
(C) 3, 1, 5, 4, 2 (D) 5, 4, 2, 1, 3

- Q.14** 1. Atomic Age 2. Metallic Age
3. Stone Age 4. Alloy Age
(A) 1, 3, 4, 2 (B) 2, 3, 1, 4
(C) 3, 2, 4, 1 (D) 4, 3, 2, 1

- Q.15** 1. Office 2. Save
3. Work 4. Earn
5. Spend
(A) 1,3,4,2,5 (B) 1,4,3,5,2
(C) 1,3,4,5,2 (D) 3,1,4,5,2

- Q.16** 1. Planet 2. Continents 3. Countries 4. Cities 5. Land
(A) 1,2,5,3,4 (B) 1,5,2,3,4 (C) 1,2,3,5,4 (D) 1,3,4,2,5
- Q.17** 1. Post-box 2. Letter 3. Envelope 4. Delivery 5. Clearance
(A) 2, 3, 1, 4, 5 (B) 3, 2, 1, 4, 5 (C) 3, 2, 1, 5, 4 (D) 3, 2, 4, 5, 1
- Q.18** 1. Foetus 2. Child 3. Baby 4. Adult 5. Youth
(A) 1, 2, 4, 3, 5 (B) 1, 3, 2, 5, 4 (C) 2, 3, 5, 4, 1 (D) 5, 4, 2, 3, 1
- Q.19** 1. Poverty 2. Population 3. Death 4. Unemployment 5. Disease
(A) 1,2,3,4,5 (B) 2,4,1,5,3 (C) 3,4,2,5,1 (D) 2,3,4,5,1
- Q.20** 1. Heel 2. Shoulder 3. Skull 4. Neck 5. Knee 6. Chest 7. Thigh 8. Stomach 9. Face 10. Hand
(A) 2, 4, 7, 10, 1, 5, 8, 9, 6, 3 (B) 3, 4, 7, 9, 2, 5, 8, 10, 6, 1 (C) 4, 7, 10, 1, 9, 6, 3, 2, 5, 8 (D) 3, 9, 4, 2, 10, 6, 8, 7, 5, 1
- Q.21** 1. Rain 2. Monsoon 3. Rescue 4. Flood 5. Shelter 6. Relief
(A) 1, 2, 3, 4, 5, 6 (B) 1, 2, 4, 5, 3, 6 (C) 2, 1, 4, 3, 5, 6 (D) 4, 1, 2, 3, 5, 6
- Q.22** 1. Farm 2. Flowers 3. Trees 4. Fruits 5. Juice
(A) 1,2,3,4,5 (B) 3,1,4,2,5 (C) 1,3,2,4,5 (D) 3,1,2,4,5
- Q.23** 1. Ceiling 2. Room 3. Floor 4. Walls 5. Foundation
(A) 5, 4, 1, 3, 2 (B) 5, 4, 3, 1, 2 (C) 4, 5, 3, 1, 2 (D) 4, 5, 1, 2, 3
- Q.24** 1. Puberty 2. Adulthood 3. Childhood 4. Infancy 5. Senescence 6. Adolescence
(A) 2, 4, 6, 3, 1, 5 (B) 4, 3, 1, 6, 2, 5 (C) 4, 3, 6, 2, 1, 5 (D) 5, 6, 2, 3, 4, 1
- Q.25** 1. Cutting 2. Dish 3. Vegetable 4. Market 5. Cooking
(A) 1, 2, 4, 5, 3 (B) 3, 2, 5, 1, 4 (C) 4, 3, 1, 5, 2 (D) 5, 3, 2, 1, 4
- Q.26** 1. Never 2. Sometimes 3. Generally 4. Seldom 5. Always
(A) 5, 2, 1, 3, 4 (B) 5, 2, 4, 3, 1 (C) 5, 3, 2, 1, 4 (D) 5, 3, 2, 4, 1
- Q.27** 1. Table 2. Tree 3. Wood 4. Seed 5. Plant
(A) 1, 2, 3, 4, 5 (B) 1, 3, 2, 4, 5 (C) 4, 5, 2, 3, 1 (D) 4, 5, 3, 2, 1
- Q.28** 1. Milky way 2. Sun 3. Moon 4. Earth 5. Stars
(A) 1, 4, 3, 2, 5 (B) 2, 3, 4, 5, 1 (C) 3, 4, 2, 5, 1 (D) 4, 3, 2, 5, 1
- Q.29** 1. Sea 2. Rivulet 3. Ocean 4. River 5. Glacier
(A) 5, 2, 1, 3, 4 (B) 5, 2, 4, 1, 3 (C) 5, 4, 2, 3, 1 (D) 5, 4, 3, 2, 1
- Q.30** 1. Plane 2. Take off 3. Land 4. Airport 5. Runway
(A) 4, 1, 5, 3, 2 (B) 4, 5, 3, 1, 2 (C) 4, 5, 2, 1, 3 (D) 4, 5, 1, 2, 3

Q.31 Arrange the following in a meaningful sequence:
A = Birth, B = Death, C = Funeral, D = Marriage,
E = Education.
(A) AEDBC (B) ADECB
(C) AEBDC (D) ADEBC

Q.32 Arrange the following in a meaningful sequence:
A = Study, B = Service, C = Examination,
D = Earning, E = Result.
(A) EACDB (B) ABECD
(C) ACEBD (D) AECBD

Q.33 Arrange the following words in the sequence in which they occur in the dictionary, then choose the correct option
(i) BHAGWAN (ii) BHAGWAT
(iii) BHAGIRATH (iv) BHAGAT
(A) iv, i, iii, ii (B) iv, ii, i, iii
(C) iv, iii, ii, i (D) iv, iii, i, ii

Instruction: According to the question, Choose the correct option logically in question no. 34 to 37.

Q.34 (1) Embryo (2) Child
(3) Baby (4) Middle Aged
(5) Young
(A) 1,3,4,5,2 (B) 1,3,5,2,4
(C) 1,3,2,5,4 (D) 1,3,4,2,5

Q.35 (1) Poverty
(2) Population
(3) death
(4) Unemployment
(5) Disease
(A) 2,4,1,5,3 (B) 1,2,3,4,5
(C) 2,3,4,5,1 (D) 2,4,5,1,3

Q.36 (1) Accident (2) Judge
(3) Doctor (4) Lawyer
(5) Police
(A) 1,3,4,2,5 (B) 1,3,5,4,2
(C) 1,2,3,4,5 (D) 1,2,5,4,3

Q.37 (1) Golden Jubilee
(2) Silver Jubilee
(3) Anniversary
(4) Diamond Jubilee
(5) Centenary Celebrations
(A) 2,1,3,4,5 (B) 2,3,4,5,1
(C) 3,1,2,4,5 (D) 3,2,1,4,5

ANSWER KEY

EXERCISE

Que.	1	2	3	4	5	6	7	8	9	10	11	12	13	14	15	16	17	18	19	20
Ans.	B	D	D	C	A	B	D	A	B	B	B	C	C	C	C	B	A	B	B	D
Que.	21	22	23	24	25	26	27	28	29	30	31	32	33	34	35	36	37			
Ans.	C	C	A	B	C	D	C	C	B	D	A	C	D	C	A	B	D			

SOLUTIONS

EXERCISE

- Sol.1 [B]**
Order of body parts from top is :
Skull, Face, Neck, Shoulder, Legs.
- Sol.2 [D]**
Order of planets are Galaxy, Stars, Sun, Planet, Moon.
- Sol.3 [D]**
Correct order is : College, Teacher, Guide, Study, Exam.
- Sol.4 [C]**
Correct order is : Animals, Vertebrates, Mammals, Cow.
- Sol.5 [A]**
Correct order is : Place, Society, Buildings, Flat, Home.
- Sol.6 [B]**
Correct order is : Book, Chapter, Paragraph, Sentence, Word, Letter.
- Sol.7 [D]**
Correct order is : Measure, Mark, Cut, Tailor, Put on.
- Sol.8 [A]**
Correct order is : Country, Forest, Trees, Wood, Furniture.
- Sol.9 [B]**
Correct order is : Education, Interview, Selection, Job, Salary.
- Sol.10 [B]**
Correct order is : Child, Play, Games, Chess, Happy.
- Sol.11 [B]**
Correct order is : Book, Index, Introduction, Chapter, Questions.
- Sol.12 [C]**
Correct order is : Plant, Grain, Dough, Bread, Sandwich.
- Sol.13 [C]**
Correct order is : Tirupati, Andhra Pradesh, India, World, Universe.
Tirupati is a city in Andhra Pradesh.
- Sol.14 [C]**
Correct sequence is : Stone age → Metallic age → Alloy age → Atomic age.
When human was not civilized he used stone. Then he start using metal, so metallic age. Alloy is combination of metal. Then came alloy age, finally human is well known to atoms so finally atomic age.
- Sol.15 [C]**
Correct sequence is : Office → Work → Earn → Spend → Save.
- Sol.16 [B]**
Correct sequence is : Planet → Land → Continents → Countries → Cities.
- Sol.17 [A]**
Correct sequence is : Letter → Envelope → Post-box → Delivery → Clearance.
- Sol.18 [B]**
Correct sequence is : Foetus → Baby → Child → Youth → Adult.
- Sol.19 [B]**
Correct sequence is : Population → Unemployment → Poverty → Disease → Death.
- Sol.20 [D]**
Correct sequence is : Skull → Face → Neck → Shoulder → Hand → Chest → Stomach → Thigh → Knee → Heal.
- Sol.21 [C]**
Correct sequence is : Monsoon → Rain → Flood → Rescue → Shelter → Relief.
- Sol.22 [C]**
Correct sequence is : Farm → Trees → Flowers → Fruits → Juice.

- Sol.23 [A]**
Correct sequence is : Foundation → Walls → Ceiling → Floor → Room.
- Sol.24 [B]**
Correct sequence is : Infancy → Childhood → Puberty → Adolescence → Adulthood → Senescence.
- Sol.25 [C]**
Correct sequence is : Market → Vegetable → Cutting → Cooking → Dish.
- Sol.26 [D]**
Correct sequence is : Always → Generally → Sometimes → Seldom → Never.
- Sol.27 [C]**
Correct sequence is : Seed → Plant → Tree → Wood → Table.
- Sol.28 [C]**
Correct sequence is : Moon → Earth → Sun → Stars → Milky way.
- Sol.29 [B]**
Correct sequence is : Glacier → Rivulet → River → Sea → Ocean.
- Sol.30 [D]**
Correct sequence is : Airport → Runway → Plane → Take off → Land.
- Sol.31 [A]**
Correct sequence is : Birth → Education → Marriage → Death → Funeral.
- Sol.32 [C]**
Correct sequence is : Study → Examination → Result → Service → Earning.
- Sol.33 [D]**
Correct sequence according to dictionary is :
BHAGAT → BHAGIRATH → BHAGWAN
→ BHAGWAT.
- Sol.34 [C]**
Correct sequence is : Embryo → Baby → Child → Young → Middle Aged.
- Sol.35 [A]**
Correct sequence is : Population → Unemployment → Poverty → Disease → Death.
- Sol.36 [B]**
Correct sequence is : Accident → Doctor → Police → Lawyer → Judge.
- Sol.37 [D]**
Correct sequence is :
Anniversary → After one year
Silver Jubilee → After 25 year
Golden Jubilee → After 50 year
Diamond Jubilee → After 60 year
Centenary Celebrations → After 100 year

SOCIAL SCIENCE

THE RISE OF NATIONALISM IN EUROPE

Chapter Outline

- ❖ The Theme of Frederic Sorrieu's Painting
- ❖ French Revolution and the idea of the nation
- ❖ The Making of Nationalism in Europe
- ❖ The age of Revolutions 1830-1848
- ❖ The Making of Germany and Italy
- ❖ Visualising the Nation
- ❖ Nationalism and Imperialism

The Theme of Frederic Sorrieu's Painting



The Dream of Worldwide Democratic and Social Republics - The Pact Between Nations,
a print prepared by Frederic Sorrieu, 1848.

- (i) In 1848, Frederic Sorrieu, a French artist, prepared a series of four prints visualizing his dream of a world made up of 'democratic and social Republics', as he called them.
- (ii) The first print of the series, shows the people of Europe and America – men and women of all ages and social classes – marching in a long train and offering homage to the statue of Liberty as they pass by it.

- (ii) A female figure was shown with the torch of Enlightenment in one hand and the Charter of the Rights of Man in the other.
- (iii) On the earth in the foreground of the image lie the shattered remains of the symbols of absolutist institutions.
- (iv) In Sorrieu's utopian vision, the peoples of the world are grouped as distinct nations, identified through their flags and national costume.

The French Revolution and The Idea of the Nation

France was a full fledged territorial state in 1789 under the rule of an absolute monarch. The political and constitutional changes that came in the wake of French Revolution led to the transfer of sovereignty from the monarchy to a body of French citizens. The **revolution proclaimed** that it was the people who would hence forth constitute the nation and shape its destiny.

◆ Steps Taken by French Revolutionaries :

- (i) The ideas of **La Patrie (the fatherland)** and **Le Citoyen (the citizen)** emphasized the notion of a united community enjoying equal rights under a constitution.
- (ii) A new French **flag, the tricolour**, was chosen to replace the former royal standard. New **hymns** were composed, **oaths** taken and martyrs commemorated, all in the name of a **nation**.
- (iii) The Estates General was elected by the body of active citizens and renamed the **National Assembly**.
- (iv) A **centralised administrative system** was put in place and it formulated **uniform laws** for all citizens within its territory.
- (v) Internal customs duties and dues were abolished and a **uniform system of weights and measures** was adopted.
- (vi) Regional dialects were discouraged and French, as it was spoken and written in Paris, became the common language of the nation.
- (vii) The revolutionaries further declared that it is was the mission and the destiny of the French nation to liberate the peoples of Europe from despotism.

◆ Civil Code of 1804 :

- (i) Though a return to monarchy Napoleon had, no doubt, destroyed democracy in France, but in the administrative field he had incorporated revolutionary principles in order to make the whole system more rational and efficient.
- (ii) The civil code of 1804-usually known as the **Napoleonic code** did away with all privileges based on birth, established equality before the law and secured the right to property.
- (iii) This code was exported to the regions under French Control.
- (iv) In the Dutch Republic in Switzerland, in Italy and Germany. Napoleon abolished the feudal system and freed peasants from serfdom and manorial dues.

- (v) In the towns too guild restrictions were removed.
- (vi) Transport and communication systems were improved
- (vii) Peasants, artisans, workers and new businessmen enjoyed a new-found freedom.

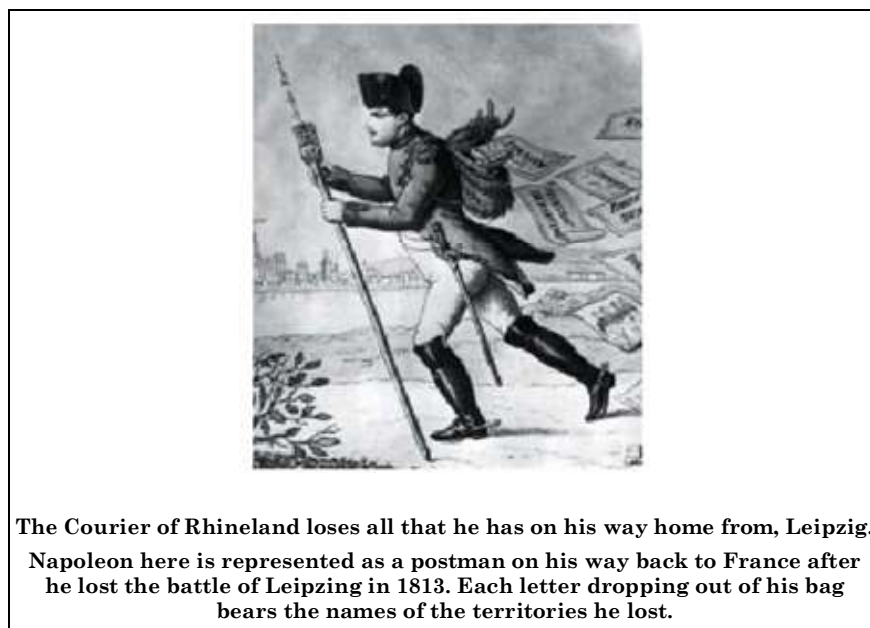

The Making of Nationalism in Europe

In the mid-eighteenth century, Germany, Italy and Switzerland were divided into Kingdoms, duchies and cantons whose rulers had their autonomous territories. Eastern and Central Europe were under autocratic monarchies within the territories of which lived diverse people. They did not see themselves as sharing a collective identity or a common culture. Such differences did not easily promote a sense of political unity. The only tie binding these diverse groups together was common allegiance to the emperor.

COMPETITIVE LEVEL

- 1797 Napoleon invades Italy; Napoleonic wars begin.
- 1814-1815 Fall of Napoleon; the Vienna Peace Settlement.
- 1821 Greek struggle for independence begins.
- 1848 Revolutions in Europe; artisans, industrial workers and peasants revolt against economic hardships; middle classes demand constitutions and representative governments; Italians, Germans, Magyars, Poles, Czechs, etc. demand nation-states.
- 1859-1870 Unification of Italy.
- 1866-1871 Unification of Germany. 1905 Slav nationalism gathers force in the Habsburg and Ottoman Empires.



(i) The Aristocracy and the New Middle Class :

- (1) The members of this class were united by a common way of life that cut across regional diversions. They owned castles in the countryside and also town houses. This powerful autocracy was however, numerically a small group. The majority of the population was made up of the peasantry.

- (2) Industrialisation began in England in the second half of the 18th century, but in France and parts of the German states it occurred only during the 19th century.
- (3) In its wake new social groups came in to being a working class population and *middle classes made up of industrialists, businessmen, professionals*. It was among the educated, liberal middle classes that ideas of national unity following the abolition of aristocratic privileges gained popularity.

(ii) What did Liberal Nationalism Stand for?

- (1) The term 'Liberalism' derives from the Latin root 'liber' meaning free. For the new middle classes liberalism stood for freedom for the individual and equality of all before the law. Politically it emphasised the concept of government. Since the French Revolution, liberalism had stood for the end of autocracy and clerical privileges a constitutional and representative government through parliament.
- (2) In the economic sphere, liberalism stood for the freedom of markets and the abolition of state imposed restrictions on the movement of goods and capital. During the 19th century this was a strong demand of the emerging middle classes.
- (3) Napoleon's administrative measures had created out of countless small principalities a confederation of 39 states. Each of these possessed its own currencies, and weights and measures. Which involved time-consuming calculations ?
- (4) In 1834, a customs union or zollverein was formed by the initiative of Prussia and joined by most of the German states. The union abolished tariff barriers and reduced the number of currencies from over thirty to two. The creation of network of railways further stimulated mobility, harnessing economic interests to national unification. According to Prof. Rierdich List, the aim of the zollverein was to bind the Germans economically into a nation.

(iii) A New Conservatism after 1815 :

After the death of Napoleon in 1815 European governments were driven in a spirit of **conservatism**. It means a political philosophy that stressed the importance of tradition established institution and customs and preferred gradual development to quick change.

In 1815 representatives of the European powers. Britain, Russia, Prussia and Austria. Who had collectively defeated Napoleon met at Vienna to draw up a settlement for Europe.

- (1) The Bourbon dynasty, which had been deposed during the French revolution, was restored to power, and France lost the territories it had annexed under, Napoleon.
- (2) A series of states were set up on the boundaries of France to prevent French expansion in future. Thus the kingdom of the Netherlands, which included Belgium, was set up in the north and Geneva was added to Piedmont in the South.
- (3) Prussia was given important territories on its western frontiers, while Austria was given control of northern Italy. But the German confederation of 39 states that had been set up by Napoleon was left untouched. Russia was given part of Poland while Prussia was given a portion of Saxony. The main intension was to restore the monarchies that had been over thrown by Napoleon and create a new conservative order in Europe.

(iv) The Revolutionaries :

After 1815, the fear of repression drove many liberal nationalists underground. Secret societies sprang up in many European states to train revolutionaries and spread their ideas. To be revolutionary at this time meant a commitment to oppose monarchical forms that had been established after the Vienna Congress and to fight for liberty and freedom. Most of these revolutionaries also saw the creation of nation states as a necessary part of this struggle for freedom.

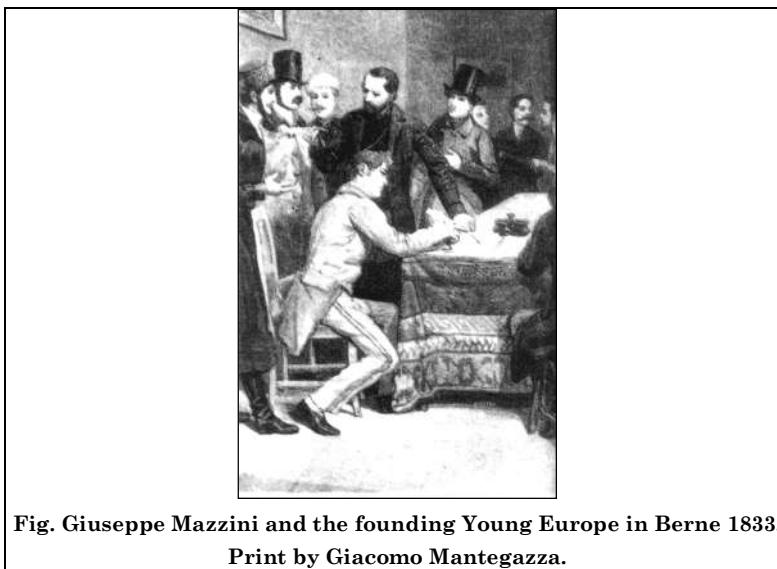

Giuseppe Mazzini : One such was the Italian revolutionary Giuseppe Mazzini. Born in 1807. At the age of 24 he was sent on exile in 1831 for attempting revolution in Liguria. He became a member of the secret society of the Carbonari. He subsequently founded two more underground societies first, Young Italy in Marseilles and Young Europe in Berne whose members were like minded. Mazzini believed that God had intended to be the natural interest of man kind.

The Age of Revolutions (1830-1848)

- (1) The first revolt took place in France in July 1830. The kings who had been restored to power during the conservative's reaction after 1815, were now overthrown by liberal revolutionaries who installed a constitutional monarchy with Louis Philippe. **'When France Sneezes'** Metternich once remarked 'the rest of Europe catches Cold'.
- (2) **Uprising in Brussels** : The July Revolution sparked an uprising in Brussels which led to Belgium breaking away from the United Kingdom of the Netherlands.
- (3) **Uprising in Greece** : Greece had been part of the Ottoman Empire since the fifteenth century. The growth of revolutionary nationalism in Europe sparked off a struggle for independence amongst the Greeks which began in 1821. Nationalists in Greece got support from other Greeks living in exile and also from many West Europeans who had sympathies for ancient Greek culture. Poets and artists lauded Greece as the cradle of European civilisation and mobilised public opinion to support its struggle against a Muslim empire. The English poet Lord Byron organised funds and later went to fight in the war, where he died of fever in 1824. Finally, the Treaty of Constantinople of 1832 recognised Greece as an independent nation.

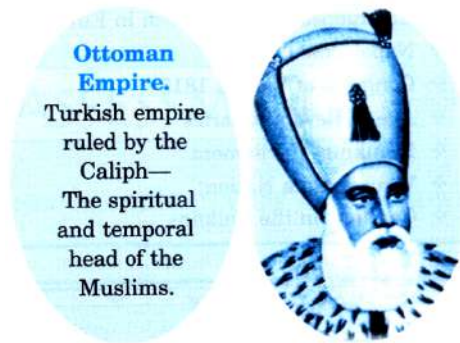

(i) **The Romantic Imagination and National Feeling :**

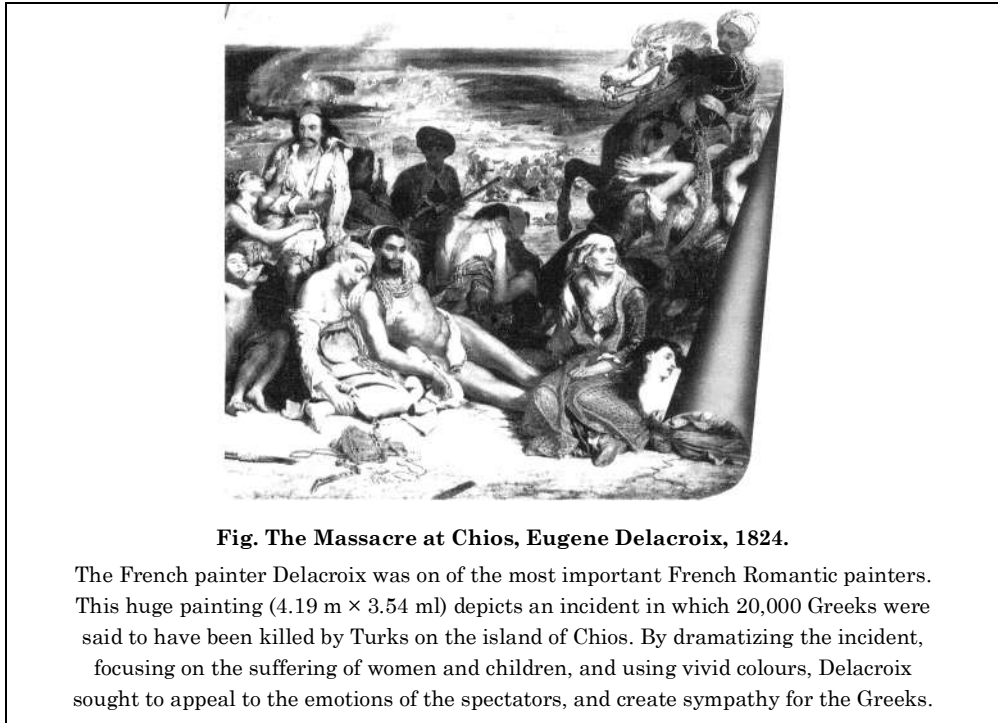

Fig. The Massacre at Chios, Eugene Delacroix, 1824.

The French painter Delacroix was one of the most important French Romantic painters. This huge painting (4.19 m × 3.54 m) depicts an incident in which 20,000 Greeks were said to have been killed by Turks on the island of Chios. By dramatizing the incident, focusing on the suffering of women and children, and using vivid colours, Delacroix sought to appeal to the emotions of the spectators, and create sympathy for the Greeks.

- (1) Romanticism, a cultural movement which sought to develop a particular form of nationalist sentiment.
- (2) Romantic artists and poets generally criticised the glorification of reason and science and focused instead on emotions, intuition and mystical feelings. Their effort was to create a sense of shared collective heritage of common cultural past.
- (3) The other Romantics as the German philosopher to hear G. Herder claimed that true German culture was to be discovered among the common people. It was through folk songs, folk poetry and folk dances that the true spirit of the nation was popularised.
- (4) The Emphasis on Vernacular language and the collection of local folklore was not just to recover an ancient national spirit, but also to carry the modern nationalist message to large audiences who were mostly illiterate.
- (5) Karol Kurpinski, for example, celebrated the national struggle through his operas and music, turning folk dances like the polonaise and mazurka into nationalist symbols.

- (6) Language too played an important role in developing nationalist sentiments. After Russian occupation, the Polish language was forced out of schools and the Russian language was imposed every where.

(ii) Hunger, Hardship and Popular Revolt :

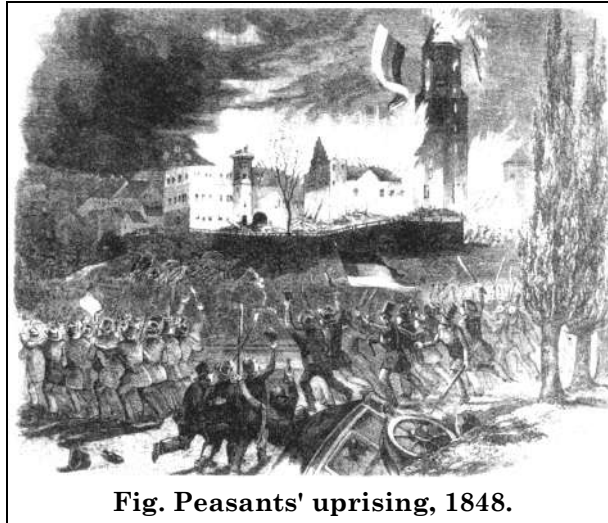

Fig. Peasants' uprising, 1848.

- (1) The 1830s were years of great economic hardship in Europe. Population from rural areas migrated to the cities to live in over crowded slums. Europe where the aristocracy still enjoyed power, peasants struggled under the burden of feudal dues and obligations.
- (2) The year 1848 was one such year. Food shortage and widespread unemployment brought the population of Paris out on the roads. Barricades were erected and Louis Philippe was forced to leave National Assembly proclaimed a Republic, granted suffrage to all adult males above 21 and granted the right to work. National workshops to provide employment were set up.
- (3) On 4 June at 2 P.M. a large crowd of weavers emerged from their homes and marched in Paris up to the intention of their contractor demanding higher wages. They were treated with scorn and threats alternately. Following this a group of them forced their way into the house, smashed its window panes; furniture proclaimed. The contractor fled with his family to a neighbouring village, which however refused to shelter such a person. He returned 24 hours later having requested the army. In the exchange that followed eleven weavers were shot.

(iii) 1848 : The Revolution of the Liberals :

Parallel to the revolts of the poor, unemployed and starving peasants and workers in many European countries in the year 1848, a revolution led by the educated middle classes was under way. Events of February 1848 in France had brought about the abdication of the monarch and a republic based on universal male suffrage had been proclaimed. In other parts of Europe where independent nation. States did not yet exist such as Germany, Italy, Poland, the Austro Hungarian Empire men and women unification. They took advantage of the growing popular unrest to push their demands for the creation of a nation-state on a parliamentary principles a constitution, freedom of the Press and freedom of association.

Frankfurt Parliament :

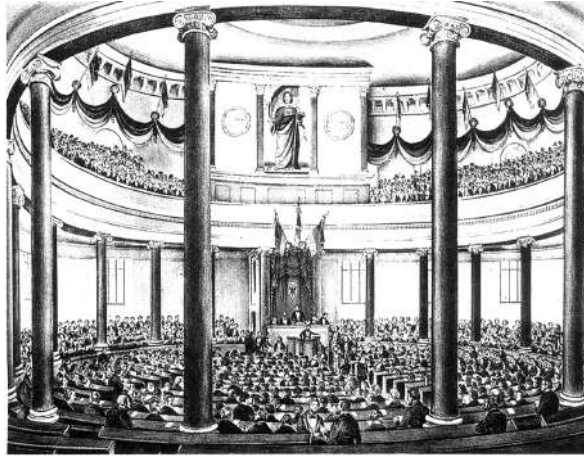

Fig. The Frankfurt parliament in the Church of St. Paul.
Contemporary colour print. Notice the women in the upper left gallery.

In the German regions a large number of political association came together in the city of Frankfurt and decided to vote for an all-German National Assembly. On 18 May 1848, 831 elected representatives marched in a festive procession to take their places in the Frankfurt parliament convened in the Church of St. Paul. They drafted a constitution for a German nation to be headed by a monarchy subject to a parliament.

- **Obstacles :**

- (1) Friedrich Wilhelm IV, King of Prussia rejected it and joined other monarchs to oppose the elected assembly.
- (2) While the opposition of the aristocracy and military became stronger, the social basis of parliament eroded. The parliament was dominated by the middle classes who resisted the demands of workers and artisans and consequently lost their support.
- (3) Issue of extending political rights to women was a controversial one within the liberal movement, they were denied suffrage rights during the election of the Assembly.

- **Outcomes :**

- (1) Though conservative forces were able to suppress liberal movements in 1848, they could not restore the old order.
- (2) In the years after 1848, the autocratic monarchies of Central and Eastern Europe began to introduce the changes that had already taken place in Western Europe before 1815.
- (3) The Habsburg rulers granted more autonomy to the Hungarians in 1867.

The Making of Germany and Italy

(i) Germany - Can the Army be the Architect of nation ?

- (1) Nationalist feelings were spreading among middle class Germans, who in 1848 tried to unite the different regions of the German confederation into a nation state governed by an elected parliament.
- (2) This liberal initiative to nation building was however, repressed by the combined forces of the monarchy and the military supported by the large land owners (called Junkers) of Prussia. From then on Prussia took on the leadership of the movement for national unification.

- (3) Its Chief Minister Otto von Bismarck was the architect of this process carried out with the help of Prussian army. 3 wars over 7 years with Austria Denmark and France were fought between 1866 to 1871 ended in the Prussian victory and completed the task of unification of Germany in 1871 Prussian king Williams I proclaimed themselves the king.



- (4) The nation building process in Germany had demonstrated the dominance of Prussian state power. The new state placed a strong emphasis on modernising the currency, banking, legal and judicial system in German Prussian measures and procedures often became a model for the rest of Germany.



Unification of Germany (1866-71)

(ii) Italy Unified :

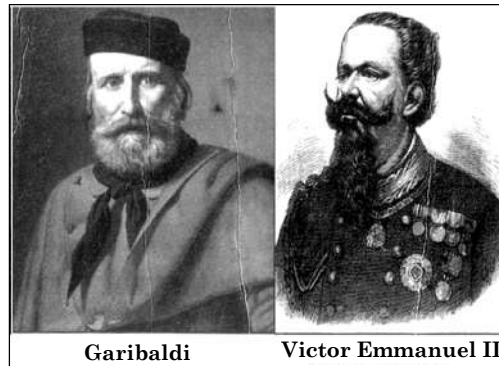

- (1) During the middle of the 19th Century, Italy was divided into seven states of which only one Sardinia predominance was ruled by an Italian princely house. The north was under Austrian Habsburgs, the centre was ruled by the Pope and the southern regions were under the domination of the Bourbon Kings of Spain. Even the Italian language had not acquired one common form and still had many regional and local variations.
- (2) Chief Minister Cavour who led the movement to unify the regions of Italy was neither a revolutionary nor a democrat. Like many other wealthy and educated members of the Italian elite, he spoke French better than he did Italian.
- (3) Through a tactful diplomatic alliance with France engineered by Cavour, Sardinia Piedmont succeeded in defeating the Austrian forces in 1859. Apart from regular troops a large number of armed volunteers under the leadership of Giuseppe Garibaldi joined the fray in 1860, they marched into south Italy and the kingdom of the Two Sicilies and succeeded in winning the support of the local peasants in order to drive out the Spanish rulers.
- (4) In 1861 Victor Emmanuel was proclaimed king of united Italy. However, much of the Italian population, among whom rates of illiteracy were very high, remained blissfully unaware of liberal nationalist ideology. The peasant masses who had supported Garibaldi in Southern Italy had never heard of 'Italia' and believed that 'La Italia' was Victor Emmanuel's wife.



Italian States Before Unification, 1858.



Italy After Unification.

The map shows the year in which different regions (seen in Fig. 14(a)) become part of a unified Italy.

(iii) The strange case of Britain :

- (1) In Britain the formation of the nation state was not the result of sudden upheaval or revolution. It was the result of a long draw-out process. There was no British nation prior to the 18th century. The primary identities of the people who inhabited the British ideas were ethnic ones-such as English, Welsh, Scot or Irish. All of these ethnic groups had their own cultural and political traditions.
- (2) But as the English nation steadily grew in wealth, importance and power, it was able to extend its influence over the other nations of the islands. The English Parliament, which had seized power from the monarchy in 1688 at the end of a protected conflict, was the instrument through which a nation state with England at its centre, came to be forged.
- (3) The Act of union (1707) between England and Scotland that resulted in the formation of the 'United Kingdom of Great Britain' meant in effect, that England was able to impose its influence on Scotland. The British Parliament was hence forth dominated by its English members.
- (4) Ireland suffered a similar fate. It was a country deeply divided between Catholics and Protestants. The English helped the Protestants of Ireland to impose their dominance over a largely catholic country. Catholic revolts against British dominance were brutally suppressed. After a failed revolt led by Wolfe Tone and his United Irishmen (1798). Ireland was forcibly incorporated into the united kingdom in 1801. A new 'British nation' was forged through the propagation of dominant English culture.

Visualizing The Nation

- (1) Artists in the 18th and 19th centuries found a way out by personifying nation. In other words they represented a country as if it were a person.
- (2) Nations were then portrayed as female figures. The nation did not stand for any particular woman in real life, rather it sought to give the abstract idea of the nation a concrete form.
- (3) That is, the female figure became an allegory of the nation. After this so many countries used the same symbol (female) like Marianne in France and Germania in Germany.
- (4) Similarly, Germania became the allegory of the German nation. In visual representations, Germania wears a crown of oak leaves, as the German oak stands for heroism.





Germania, Philip Veit, 1848.

The artist prepared this painting of Germania on a cotton banner, as it was meant to hang from the ceiling of the Church of St. Paul where the Frankfurt parliament was convened in March 1848.

Nationalism and Imperialism

- (1) The most serious source of nationalist tension in Europe after 1871 was the area called the Balkans. The Balkans was region of geographical and ethnic variation comprising modern day Romania, Bulgaria, Albania, Greece, Macedonia, Croatia, Bosnia-Herzegovine, Slovenia, Serbia and Montenegro whose inhabitants were broadly known as the slavs.
- (2) A large parts of the Balkans was under the control of the Ottoman Empire.
- (3) The spread of the ideas of romantic nationalism in the Balkans together with the disintegration of the Ottoman Empire made this region very explosive.
- (4) All through the 19th century the Ottoman Empire had sought to strengthen itself through modernisation and internal reforms but with very little success. One by one its European subject nationalities broke away from its control and declared independence.
- (5) The Balkan people asked their claims for independence or political rights on nationalistic and used history to prove that they had once been independent but had subsequently been subjugated by foreign powers.
- (6) Hence the rebellions nationalities in the Balkans thought of their struggles as attempts to win back their long lost independence.

DATELINE

- 1714 : George-I became the king of the Great Britain.
- 1715 : Louis XV became the king of France.
- 1740–1748 : The war of the Austrian Succession.
- 1756–1763 : The Seven Years War.
- 1776 : The American Declaration of Independence.

- 1789 : The French Revolution occurred.
- 1797 : Napoleon invaded Italy ; Napoleonic wars began.
- 1814 : The First Treaty of Paris : established a lenient peace with France.
- 1814-1815 : Fall of Napoleon; the Vienna Peace Settlement; Napoleon escaped from Elba, gathered a new army, but was defeated at Waterloo.
- 1821 : Greek struggle for independence began.
- 1732 : Greece gained independence from the Ottoman Empire.
- 1831 : Giuseppe Mazzini established Young Italy.
- 1849-1878 : The reign of Victor Emmanuel-II of Piedmont-Sardinia.
- 1852 : Camillo Cavour became the premier of Sardinia-Piedmont.
- 1859 : Piedmont and France defeated Austria; Piedmont annexed Lombardy.
- 1861 : The Kingdom of Italy was announced; Victor Emmanuel-II of Piedmont-Sardinia became king of Italy.
- 1870 : After France declared war on Prussia, Italy annexed Rome.
- 1861-1888 : Reign of king william-I of Prussia.
- 1867 : Prussia created the North German Confederation.
- 1770-1871 : Franco-Prussian war.
- 1871 : The German Empire war formed; Germany annexed Alsace and Lorraine., the Provinces of France
- 1848 : Revolutions in Europe; artisans, industrial workers and peassants revolt against economic hardships; middle classes demand constitutions and representative governments; Italians, Germans, Magyars, Poles, Czechs, etc. demand nation-states.
- 1905 : Slav nationalism gathered force in the Habsburg and Ottoman Empires.

GLOSSARY

1. **Nationalism** : A sense of belonging to one nation. Feeling or pride and patriotism towards the country one belongs.
2. **Absolutist** : Unrestricted, despotic and authoritarian often refers to a centralised repressive monarchical government.
3. **Utopian** : An ideal situation a vision too good to be realised in practice.
4. **Nation state** : A state having a common and contiguous boundary with inhabitants, people sharing common language, race and religion. Majority of its citizen develop a sense of common identity and share a common history.

5. **Plebiscite** : A direct vote by which the people of a region, themselves decide to accept or reject a proposal.
6. **Sovereignty** : Supreme Power.
7. **Monarchy** : Form a government headed by a monarch or a hereditary or dynamics ruler.
8. **The Estates General** : Referred to the French Parliament an elected body which was renamed as the National Assembly after the revolution of 1789.
9. **Civil Code** : A systematic set of laws for the citizen.
10. **Habsberg Empire** : The empire that ruled Austria, Hungary including the Alpine region of Tyrol, Austria, Sudetenland, Bohemia. It also included Italian provinces of Lombardy and Venetia.
11. **Liberalism** : Derived from the word 'liber' meaning free. The idea of liberalism stands for freedom of individual and equality of all before law. Politically it refers to representative government.
12. **Suffrage** : The right to vote.
13. **Elle** : Elle was used to measure cloth, prevalent in German states.
14. **Zollverein** : A custom union, formed in 1034 in Prussia to remove barriers of trade.
15. **Conservatism** : A spirit or philosophy which believes in maintaining and preserving traditional values and institutions. It prefers gradual change to quick and drastic change.
16. **Carbonari** : A secret society of Italy consisting of young revolutionaries.
17. **Young Italy** : A secret society founded by Mazzine at Masseles for organising revolutionary activities.
18. **Ottoman Empire** : Turkish empire ruled by the caliph. The spiritual and temporal head of the muslim.
19. **Romanticism** : A cultural movement which aimed at developing a particular form of national sentiment and promote a feeling of collective heritage as the basis of motion.
20. **Das volk** : A German word meaning common people.
21. **Republic** : A state where the head of the state is elected and does not hold a hereditary position.
22. **Feminist** : People who advocate women's right on the basis of equality of sexes.
23. **Ideology** : System of ideas reflecting a particular social and political vision.
24. **Allegory** : Symbol representing an abstract idea; an idea identified through a person or a thing.
25. **Balkan region** : A region in Europe with geographical and ethnic variation. The region covers the states of modern day Romania, Bulgaria, Albania, Greece, Macedonia, Croatia, Bosnia, Herzegovina, Slovenia, Serbia, Montenegro. The inhabitants of the region are known as the Slavs.

EXERCISE-1

➤ Very Short Answer Type Questions

- Q.1** What is “Statue of Liberty”? What does the statue signify ?
- Q.2** Name four European powers who collectively defeated Napoleon.
- Q.3** With what aim was the Treaty of Vienna (1815) signed?
- Q.4** When and under whom was the constitutional monarchy setup in France?
- Q.5** Name the treaty which recognised Greece as an independent nation.

➤ Short Answer Type Questions

- Q.6** What are the main symbols of an independent nation ?
- Q.7** What are the most important achievements of the French Revolution of 1789 ?
- Q.8** What was the significance of the Napoleonic code ?
- Q.9** Examine the reasons for the political disunity in Habsburg empire of Austria and Hungary.

- Q.10** How did the growth of industrialisation change the social and political equation of Europe ?
- Q.11** Examine the liberal ideology imbibed by the revolutionary leader after French revolutions.
- Q.12** How did liberalism give rise to economic nationalism?
- Q.13** What was the impact of Treaty of Vienna (1815) on European people?
- Q.14** Describe the contribution of Mazzini in the unification of Italy?

➤ Long Answer Type Questions

- Q.15** Mention the main factors responsible for the rise of nation state.
- Q.16** What were the major proposals of the Vienna Congress.
- Q.17** Briefly trace the process of the unification of Germany and that of Britain.
- Q.18** Who was Count Camillo de Cavour? Mention his contributions.

EXERCISE-2

- Q.1** A nation state, according to the French philosopher Ernst Renan, was formed by
(A) A common language, race, religion or territory
(B) A nation with a shared history or descent, of endeavors, sacrifice and devotion, wish to perform still more great deeds together
(C) A large scale solidarity, its existence a daily plebiscite
(D) Both (B) and (C)
- Q.2** Federic Serrieu, a French artist, in his series of four prints (1848) visualised his dream of a world as :
(A) A world made up of 'democratic and social republics'
(B) A world made up of one nation, one world
(C) A world with one absolute ruler
(D) A world following one religion, one language
- Q.3** The Civil Code of 1804, also known as the Napoleonic Code, established :
(A) Equality before the law
(B) Secured the right to property
(C) Did away with all the privileges based on birth
(D) All the above
- Q.4** Which new spirit guided European nations after Napoleon's defeat?
(A) Fascism (B) Conservatism
(C) Nazism (D) Communism
- Q.5** All the new regimes, set up in 1815, were autocratic because :
(A) They did not tolerate criticism and dissent
(B) They imposed censorship laws to control what was said in newspapers, plays, songs etc.
(C) They curbed activities which questioned their legitimacy
(D) All the above
- Q.6** The purpose behind the painting "The Massacre at Chios" by Eugene Delacroix, 1824, was:
(A) To appeal to the emotions of the spectators and create sympathy for the Greeks
(B) To dramatise the incident in which 20,000 Greeks were killed
(C) To focus on the suffering of women and children
(D) All the above
- Q.7** German philosopher Johann Gottfried Herder claimed that true German culture was discovered through
(A) Folk songs, folk poetry, folk dances
(B) Common people - das volk
(C) Vernacular language
(D) All the above
- Q.8** The weavers of Silesia revolted in 1845 against contractors because :
(A) The contractors who gave them orders drastically reduced their payments
(B) The contractors took advantage of their misery and desperate need for jobs
(C) Both (A) and (B)
(D) The contractors had killed eleven weavers
- Q.9** The artists of the 18th and 19th centuries personified a nation as :
(A) A particular woman to represent the nation
(B) A female figure
(C) A female figure as an allegory, to represent an abstract idea of a nation in concrete form
(D) All the above

- Q.10** Phillip Veit used the following in his painting as symbols
 (i) Broken chains,
 (ii) Sword
 (iii) Olive branch round the sword and
 (iv) Rays of the rising Sun.
 They symbolised :
 (A) (i) Heroism,
 (ii) readiness to fight
 (iii) strength
 (iv) hope
 (B) (i) Freedom
 (ii) strength
 (iii) readiness to fight
 (iv) Beginning of a new era
 (C) (i) Freedom
 (ii) readiness to fight
 (iii) willingness to make peace
 (iv) beginning of a new era
 (D) (i) Heroism
 (ii) courage
 (iii) readiness to fight
 (iv) hope
- Q.11** The two reasons which made the Balkans an explosive region after 1871 were :
 (A) The spread of ideas of romantic nationalism and the disintegration of the Ottoman Empire under whose control they were
 (B) The declaration of independence by European subject nationalities from the Ottoman Empire.
 (C) The support of history and nationalism to be independent
 (D) All the above
- Q.12** Returning from exile, Giuseppe Mazzini formed a new organisation called
 (A) National Italy (B) Young Italy
 (C) United Italy (D) Organised Italy
- Q.13** System of ideas reflecting a particular social and political vision is known as
 (A) Ideology (B) Pedagogy
 (C) Philology (D) Genealogy
- Q.14** Guiseppe Garibaldi led an army of volunteers to Rome to fight the last obstacle in the unification of Italy in the year
 (A) 1857 (B) 1867
 (C) 1877 (D) 1887
- Q.15** Napoleon invaded Italy in the year
 (A) 1781 (B) 1782
 (C) 1797 (D) 1789
- Q.16** An abstract idea or emotion which when used as a symbol to portray a theme with respect to a nation is called
 (A) An ideology (B) symbol
 (C) an allegory (D) a painted theme
- Q.17** The word *das volk* refers to
 (A) common people of France
 (B) common people of Italy
 (C) common people of Germany
 (D) common people of Russia
- Q.18** The theory that tries to make awareness of women's rights and interests based on the belief of the social, economic and political equality of the genders is known as
 (A) Humanism (B) Feminism
 (C) Post modernism (D) Culturalism
- Q.19** *la patrie*, one of the ideas used during the French Revolution to emphasize the notion of a united community, means
 (A) Holy land (B) Fatherland
 (C) Motherland (D) United land
- Q.20** The term 'liberalism' is derived from
 (A) Latin language
 (B) Russian language
 (C) French language
 (D) Greek language
- Q.21** The Architect of German unification process was
 (A) Otto von Bismarck
 (B) Hitler
 (C) Giuseppe Mazzini
 (D) John Gottfried Herder
- Q.22** In Ireland a revolt by Catholic Irishmen in the year 1798 was led by
 (A) Milton Booth (B) Wolfe Tone
 (C) McGregor (D) Potemkin
- Q.23** The Grimms brothers were
 (A) British nationals
 (B) French nationals
 (C) German nationals
 (D) Italian nationals

- Q.24** The serious source of nationalist tension after 1871 in Europe was
 (A) Germany (B) France
 (C) Balkans (D) Italy
- Q.25** In 1871, the head of new German Empire who was crowned at the Hall of Mirrors in the Palace of Versailles was
 (A) Otto von Bismarck
 (B) Kaiser William I of Prussia
 (C) Victor Emmanuel II
 (D) Hitler
- Q.26** The term 'Suffrage' means
 (A) right to vote
 (B) right to religious practice
 (C) right to property
 (D) right to express
- Q.27** The policy that Bismarck followed for the unification of Germany is known as
 (A) blood and Iron
 (B) muscle and power
 (C) suppress and Rule
 (D) blood and Nation
- Q.28** Greece was recognised as an independent nation by the treaty of
 (A) Sevres
 (B) Versailles
 (C) Constantinople
 (D) Tordesillas
- Q.29** Liberalism stood for the end of autocracy and clerical privileges since the
 (A) American Revolution
 (B) Chinese Revolution
 (C) French Revolution
 (D) Chinese Revolution
- Q.30** The Italian revolutionary Giuseppe Mazzini was born in Genoa in the year
 (A) 1805 (B) 1806
 (C) 1807 (D) 1808
- Q.31** The Treaty of Constantinople was signed in the year
 (A) 1831 (B) 1832
 (C) 1833 (D) 1834
- Q.32** The body in France which consisted of the elected representatives and led the Revolt was
 (A) Councils of clergies
 (B) General Assembly
 (C) National Assembly
 (D) People's Assembly
- Q.33** The Ottoman Empire was established by
 (A) Italians (B) Greeks
 (C) Turkish people (D) Germans
- Q.34** The Treaty of Vienna was held in
 (A) 1715 A.D. (B) 1815 A.D.
 (C) 1915 A.D. (D) 1920 A.D
- Q.35** The French Revolution took place in the year
 (A) 1769 A.D. (B) 1799 A.D.
 (C) 1779 A.D. (D) 1789 A.D.
- Q.36** The Habsburg empire ruled over the territories of
 (A) Italy
 (B) Greece
 (C) England
 (D) Austria–Hungary
- Q.37** Giuseppe Mazzini founded 'Young Europe' in
 (A) 1833 (B) 1834
 (C) 1835 (D) 1836
- Q.38** In his efforts of unifying Italian states in 1854, Victor Emmanuel II was supported by
 (A) Garibaldi (B) Cavour
 (C) Mazzini (D) Bismarck
- Q.39** The process of German unification was dominated by
 (A) Russia (B) Brandenburg
 (C) Westphalia (D) Prussia
- Q.40** The Act by which England was able to impose its influence on Scotland in 1707 was
 (A) Act of parliament.
 (B) Act of Scots.
 (C) Act of Union.
 (D) Act of English.

- Q.41** The Frankfurt Parliament was convened in the
(A) hall of Mirrors
(B) hall of Fame
(C) church its panl church
(D) parliament
- Q.42** The idea that has been personified as a female figure by the French revolution was
(A) equality. (B) liberty.
(C) fraternity. (D) society.
- Q.43** The English poet who had raised funds and went to fight against the Ottoman Turks for Greeks was
(A) William Blake (B) Andre Breton
(C) Edwin Brock (D) Lord Byron
- Q.44** The growth of revolutionary nationalism in Europe sparked off a struggle for independence amongst the Greeks in
(A) 1821 (B) 1822
(C) 1823 (D) 1824
- Q.45** According to the French revolutionaries, the mission and destiny of the French nation was to liberate the peoples of
(A) America. (B) Africa.
(C) Europe. (D) Asia.
- Q.46** Giuseppe Garibaldi joined the movement for a unified Italy in
(A) 1832 (B) 1833
(C) 1834 (D) 1835
- Q.47** The English poet Lord Byron organised funds to assist people in the
(A) American War of Independence
(B) Greek War of Independence
(C) Irish War of Independence
(D) Turkish War of Independence
- Q.48** Greece had been a part of the Ottoman Empire since the
(A) Fifteenth century
(B) sixteenth century
(C) seventeenth century
(D) eighteenth century

EXERCISE-3

(Previous Year Questions - NTSE)

- Q.1** What is the meaning of this French word "Le Citoyen" ?
(A) The people (B) The Citizen
(C) Resident (D) All above
- Q.2** Chief Minister Cavour who led the movement of unification of Italy was a
(A) Freedom Fighter
(B) A revolutionary
(C) A democrat
(D) Neither a Revolutionary nor a Democrat
- Q.3** Who hosted Congress of Vienna ?
(A) Bismark
(B) Napoleon Bonaparte
(C) Voltaire
(D) Metternich
- Q.4** Who is regarded as father of Italian unification ?
(A) Mazzini
(B) Cavour
(C) Garibaldi
(D) None of these
- Q.5** Who amongst the following ruled over Sardinia-piedmont during the middle of the nineteenth century.
(A) Italian Princely house
(B) Austrian Habsburg
(C) Pope
(D) Bourbon king of Spain
- Q.6** Who was Paul Bernard?
(A) Capitalist (B) Social worker
(C) Social reformer (D) Economist
- Q.7** Who said "When France sneezes the rest of the Europe catches cold".
(A) Garibaldi (B) Mazzini
(C) Bismarck (D) Metternich
- Q.8** Find out the statement which does not cause to Imperialism :
(A) Prosperity of Asia and Africa
(B) Weakness of Asian and African Nations
(C) Need of raw material from Asia and Africa
(D) Growing agitation in Nationalistic movement in African and Asian continent
- Q.9** Germany was unified in -
(A) 1870 (B) 1871
(C) 1872 (D) 1873
- Q.10** The tactful diplomatic alliance between Sardinia-Piedmont and France was engineered by
(A) Mazzini
(B) Cavour
(C) Garibaldi
(D) Victor Emmanuel
- Q.11** Which of following state was ruled by as Italian Princely House ?
(A) Sardinia Piedmont
(B) Papal States
(C) Venetia
(D) Tuscany
- Q.12** Which French artist prepared a series of four prints visualizing his dream of a world made up of 'Democratic and Social Republics'?
(A) Frederic Sorrieu
(B) Andreas Rebmann
(C) Karl Kaspar Fritz
(D) Giuseppe Mazzini
- Q.13** Which one of the following incidents happened first ?
(A) Convocation of Estates General
(B) Overthrow of the Jacobin Republic
(C) Debates over socialism in Russia
(D) Proclamation of the Weimar Republic
- Q.14** The German King in 1871 was
(A) Kaiser William I
(B) Napoleon III
(C) Frederik William IV
(D) Emmanuel II
- Q.15** When was the Great Economics Depression between the two World Wars held ?
(A) 1921 (B) 1929
(C) 1935 (D) 1939

ANSWER KEY

EXERCISE - 2

Ques.	1	2	3	4	5	6	7	8	9	10	11	12	13	14	15
Ans.	D	A	D	B	D	D	D	C	C	D	A	B	A	B	C
Ques.	16	17	18	19	20	21	22	23	24	25	26	27	28	29	30
Ans.	C	C	B	B	A	A	B	B	C	B	A	A	C	C	C
Ques.	31	32	33	34	35	36	37	38	39	40	41	42	43	44	45
Ans.	B	C	C	B	D	D	A	A	D	C	C	B	D	D	C
Ques.	46	47	48												
Ans.	B	B	A												

EXERCISE - 3

Ques.	1	2	3	4	5	6	7	8	9	10	11	12	13	14	15
Ans.	B	D	D	B	A	D	D	D	B	B	A	A	A	A	B

SOLUTIONS

EXERCISE-1

➤ Very Short Answer Type Questions

- Sol.1** Allegory of France, the statue signify a world wide democratic and Republic.
- Sol.2** Britain Russia Austria & Prussia
- Sol.3** Undoing the changes that had come during Napoleon war.
- Sol.4** 1791 by the National Assembly.
- Sol.5** Treaty of Constantinople.

➤ Short Answer Type Questions

- Sol.6** Shared history, Sense of common identity.
- Sol.7** France was a full fledged territorial state in 1789 under the rule of an absolute monarch. The political and constitutional changes that came in the wake of French Revolution led to the transfer of sovereignty from the monarchy to a body of French citizens.
- Sol.8**
- Though a return to monarchy Napoleon had, no doubt, destroyed democracy in France, but in the administrative field he had incorporated revolutionary principles in order to make the whole system more rational and efficient.
 - The civil code of 1804-usually known as the **Napoleonic code** did away with all privileges based on birth, established equality before the law and secured the right to property.
- Sol.9** In the mid-eighteenth century. Germany, Italy and Switzerland were divided into Kingdoms, dutchies and cantons whose rulers had their autonomous territories. Eastern and Central Europe were under autocratic monarchies within the territories of which lived diverse people. They did not see themselves as Sharing a collective identity or a common culture. Such differences did not easily promote a sense of political unity.

The only tie binding these diverse groups together was common allegiance to the emperor.

Sol.10

- Industrialisation began in England in the second half of the 18th century, but in France and parts of the German states it occurred only during the 19th century.
- In its make new social groups came in to being a working class population and *middle classes made up to industrialists, businessmen, professionals*. It was among the educated, liberal middle classes that ideas of national unity following the abolition of aristocratic privileges gained popularity.

Sol.11

- The term 'Liberalism' derives from the Latin root 'liber' meaning free. For the new middle classes liberalism stood for freedom for the individual and equality of all before the law. Politically it emphasised the concept of government. Since the French Revolution, liberalism had stood for the end of autocracy and clerical privileges a constitutional and representative government through parliament.
- In the economic sphere, liberalism stood for the freedom of markets and the abolition of state imposed restrictions on the movement of goods and capital. During the 19th century this was a strong demand of the emerging middle classes.
- Napoleon's administrative measures had created out of countless small principalities a confederation of 39 states. Each of these possessed its own currencies, and weights and measures. Which involved time-consuming calculations ?

Sol.12 In 1834, a customs union or zollverein was formed by the initiative of Prussia and joined by most of the German states. The union abolished tariff barriers and reduced the number of currencies from over thirty to two. The creation of network of railways further stimulated mobility, harnessing, economic interests to national unification. According to Prof. Rierdich List, the aim of the zollverein was to bind the Germans economically into a nation.

Sol.13 The Bourbon dynasty, which had been deposed during the French revolution, was restored to power, and France lost the territories it had annexed under, Napoleon. After 1815, the fear of repression drove many liberal nationalists underground. Secret societies sprang up in many European states to train revolutionaries and spread their ideas. To be revolutionary at this time meant a commitment to oppose monarchical forms that had been established after the Vienna Congress and to fight for liberty and freedom. Most of these revolutionaries also saw the creation of nation states as a necessary part of this struggle for freedom.

Sol.14 Giuseppe Mazzini : One such was the Italian revolutionary Giuseppe Mazzini. Born in 1807. At the age of 24 he was sent on exile in 1831 for attempting revolution in Liguria. He became a member of the secret society of the Carbonari. He subsequently founded two more underground societies first, Young Italy in Marseilles and Young Europe in Berne whose members were like minded. Mazzini believed that God had intended to be the natural interest of man kind.

▶ Long Answer Type Questions

Sol.15

- (1) Artists in the 18th and 19th centuries found a way out by personifying nation. In other words they represented a country as if it were a person.
- (2) Nations were then portrayed as female figures. The nation did not stand for any particular woman in real life, rather it sought to give the abstract idea of the nation a concrete form.
- (3) The members of this class were united by a common way of life that cut across regional diversions. They owned castles in the countryside and also town houses. This powerful autocracy was however, numerically a small group. The majority of the population was made up of the peasantry.
- (4) Industrialisation began in England in the second half of the 18th century, but in France and parts of the German states it occurred only during the 19th century.

- (5) In its make new social groups came in to being a working class population and *middle classes made up to industrialists, businessmen, professionals*. It was among the educated, liberal middle classes that ideas of national unity following the abolition of aristocratic privileges gained popularity.

Sol.16 In 1815 representatives of the European powers. Britain, Russia, Prussia and Austria. Who had collectively detected Napoleon met at Vienna to draw up a settlement for Europe.

- (1) The Bourbon dynasty, which had been deposed during the French revolution, was restored to power, and France lost the territories it had annexed under, Napoleon.
- (2) A series of states were set up on the boundaries of France to prevent French expansion in future. Thus the kingdom of the Netherlands, which included Belgium, was set up in the north and Geneva was added to Piedmont in the South.
- (3) Prussia was given important territories on its western frontiers, while Austria was given control of northern Italy. But the German confederation of 39 states that had been set up by Napoleon was left untouched. Russia was given part of Poland while Prussia was given a portion of Saxony. The main intension was to restore the monarchies that had been over thrown by Napoleon and create a new conservative order in Europe.

Sol.17 Unification of Germany : -

- (1) Nationalist feelings were spreading among middle class Germans, who in 1848 tried to unite the different regions of the German confederation into a nation state governed by an elected parliament.
- (2) This liberal initiative to nation building was however, repressed by the combined forces of the monarchy and the military supported by the large land owners (called Junkers) of Prussia. From then on Prussia took on the leadership of the movement for national unification.

- (3) Its Chief Minister Otto von Bismarck was the architect of this process carried out with the help of Prussian army. 3 wars over 7 years with Austria Denmark and France were fought between 1866 to 1871 ended in the Prussian victory and completed the task of unification of Germany in 1871 Prussian king Williams I proclaimed themselves the king.
- (4) The nation building process in Germany had demonstrated the dominance of Prussian state power. The new state placed a strong emphasis on modernising the currency, banking, legal and judicial system in German Prussian measures and procedures often became a model for the rest of Germany

Unification of Britain : -

- (1) The Act of union (1707) between England and Scotland that resulted in the formation of the 'United Kingdom of Great Britain' meant in effect, that England was able to impose its influence on Scotland. The British Parliament was hence forth dominated by its English members.
- (2) Ireland suffered a similar fate. It was a country deeply divided between Catholics and Protestants. The English helped the Protestants of Ireland to impose their dominance over a largely catholic country. Catholic revolts against British dominance were brutally suppressed. After a failed revolt led by Wolfe Tone and his United Irishmen (1798). Ireland was forcibly incorporated into the united kingdom in 1801. A new 'British nation' was forged through the propagation of dominant English culture.

Sol.18

- (2) Chief Minister Cavour who led the movement to unify the regions of Italy was neither a revolutionary nor a democrat. Like many other wealthy and educated members of the Italian elite, he spoke French better than he did Italian.
- (3) Through a tactful diplomatic alliance with France engineered by Cavour, Sardinia Piedmont succeeded in defeating the Austrian forces in 1859.

ENGLISH

A LETTER TO GOD

By - G.L. Fuentes

Introduction

Lencho was a farmer. He was an extremely hard-working man. However, his crop was destroyed in an exceedingly Hailstorm. He had a firm belief in God. He thought that God would surely help him. Thinking this he wrote a letter to God. He asked God to send him some money. At the post-office, the master read Lencho's letter. He and the other postmen of the post-office wanted to help Lencho. They collected some amount to help him and placed the collected amount into an envelope. The next Sunday, Lencho came to check whether there was any letter for him. The master gave him that envelope. Once Lencho opened the envelope he found the cash. But it was less than what he had requested for. He wrote another letter to God He asked God to send him the rest of the money. But he asked God not to send it by post because the post-office employees were a bunch of crooks.

◆ Word-Meanings

Entire = complete ; **crest** = top of a hill ; **harvest** = season's yield of crop ; **downpour** = heavy rain ; **throughout** = all through ; **Intimately** = thoroughly ; **Predict** = say in advance ; **expression** = aspect of face ; **regarded** = looked closely ; **draped** = dressed/covered ; **curtain** = cover ; **hailstones** = frozen rain ; **resemble** = be similar ; **exposing** = leaving uncovered ; **frozen** = frozen ; **pearls** = pearls ; **remain** = be still present ; **plague** = cause of disaster

◆ Detailed Summary

Lencho was a dedicated agriculturist. He was expecting a decent harvest yet sadly; a hail storm came and destroyed his harvest totally. Lencho was very sad he had the strong belief in God. He was sure that God would definitely help him. He was an extremely straightforward man. He composed a letter to God. In the letter, he asks God to send him one hundred pesos. At that point, he went to the post office and put the letter into the post box,

The postman removed the letter from the letter-box. He read the address on it and laughed badly when he rushed to the postmaster and demonstrated to him that strange letter. The postmaster also chuckled in the same way when he saw the address of God. When he read the letter, he got very serious. He lauded this man who had extraordinary confidence in God. He decided to help him. He asked the employees of the post office to give money. He gave a part of his salary. But they were able to collect only a little more than half the money requested for by Lencho. The postmaster put the money in an envelope and addressed it to Lencho. Next Sunday, Lencho came again to the post-office. He asked if there was any letter for him. The postmaster took out the letter and gave it to Lencho. Lencho was not surprised at seeing the money. But when he counted the money, he became angry. He thought that God could not have made the mistake. He took paper and ink and wrote another letter to God. Then he put the letter into the letter-box.

After Lencho had gone, the postmaster and the employees read the letter. Lencho had complained to God that he had received only seventy pesos. This time he requested God to send him the rest of the money also. But he asked God not to send the money through the mail. He wrote that the post-office employees were a bunch of crooks.

◆ **Read the Extracts and Answer the Questions that follow**

Q.1 The house - the only one in the entire valley—sat on the crest of a low hill. From this height, one could see the river and the field of ripe corn dotted with the flowers that always promised a good harvest. The only thing the earth needed was a downpour or at least a shower. Throughout the morning Lencho who knew his fields intimately had done nothing else but see the sky towards the north-east.

- (a) What did the earth need?
- (b) What did Lencho do throughout the morning?
- (c) Why had Lencho kept looking towards the north-east?
- (d) What promised a good harvest?

Ans. (a) A downpour or a shower.
(b) Lencho waited for the rain.
(c) The rain-clouds were to come from that direction.
(d) The river and the field of ripe corn dotted with the flowers promised a good harvest.

Q.2 Lencho showed not the slightest surprise on seeing the money; such was his confidence - but he became angry when he counted the money. God could not have made a mistake, nor could he have denied Lencho what he had requested.

- (a) Why did Lencho get angry?
- (b) Who could not have made a mistake in Lencho's eyes?
- (c) Why did Lencho not surprise on seeing the money?
- (d) What did Lencho find when he counted the money?

Ans. (a) Lencho got angry to find less money (that he had asked)
(b) God
(c) This was because Lencho had full confidence in God. He had firm faith in the help of God.
(d) He found only 70 pesos and not 100, the amount he had asked for.

Q.3 The moment the letter fell into the mailbox the postmaster went to open it. It said: "God: Of the money that I asked for, only seventy pesos reached me. Send me the rest, since I need it very much. But don't send it to me through the mail, because the post office employees are a bunch of crooks. Lencho".

- (a) What was Lencho thinking while writing the letter?
- (b) Why did the postmaster open the mailbox immediately after Lencho had posted his letter?
- (c) How much money had Lencho asked for?
- (d) Why did Lencho not want to send the rest of the money by mail?

Ans. (a) He thought that the post office employees had stolen a part of his money sent by God.
(b) He wanted to see Lencho's response after receiving the money. He thought Lencho must have thanked God for sending the money
(c) One Hundred Pesos.
(d) He thought post office employees were dishonest people who had cheated him.

Q.4 In the north-east huge mountains of clouds could be seen approaching. The air was fresh and sweet. The man went out for no other reason than to have the pleasure of feeling the rain on his body, and when he returned he exclaimed, "These aren't raindrops falling from the sky, they are new coins. The big drops are ten cent pieces and the little ones are fives."

- (a) Why did Lencho go out in the rain?
- (b) Why were the raindrops like 'new coins' for Lencho?
- (c) How did these new coins ultimately bring disaster to his cornfield?
- (d) Explain the description: 'The air was fresh and sweet'.

- Ans.** (a) Lencho went out in the rain to have the happiness of feeling the rain on his body.
(b) They were like new coins because Lencho thought that it would yield a good harvest, and help him earn money.
(c) These new coins i.e., rain drops soon turned into hailstones which destroyed all his crops and ruined his hopes.
(d) The clouds brought cool and sweet smelling air in their wake.

Q.5 “God,” he wrote, “if you don’t help me, my family and I will go hungry this year. I need a hundred pesos in order to sow my field again and to live until the crop comes, because of the hailstorm”

- (a) What help has he asked for?
(b) Why did he need help?
(c) Why did Lencho write a letter to God?
(d) Why was Lencho and his family in distress?

- Ans.** (a) He has asked for a hundred pesos in order to sow his field again.
(b) He needed help because the hailstorm had destroyed his crop, and his family would go hungry.
(c) Lencho’s crops were completely destroyed by the hailstorm. He had nobody to help but he had faith in God.
(d) Lencho’s crops were completely destroyed by the hailstones. He feared that he and his family would go hungry.

Q.6 Not a leaf remained on the trees. The corn was totally destroyed. The flowers were gone from the plants. Lencho’s soul was filled with sadness. When the storm had passed, he stood in the middle of the field and said to his sons. “A plague of locusts would have left more than this.’

- (a) Why did no leaf remain on the trees?
(b) How did Lencho feel after the storm?
(c) What was the major effect of the hailstorm on the field?
(d) What made Lencho sad?

- Ans.** (a) A hailstorm had struck, leaving the field bare.
(b) Lencho was utterly unhappy and distressed.
(c) The corn was totally destroyed.
(d) He was left with no corn to sow and feed his family.

Q.7 With a satisfied expression, he regarded the field of ripe corn with its flowers, draped in a curtain of rain. But suddenly a strong wind began to blow and along with the rain very large hailstones began to fall. These truly did resemble new silver coins. The boys, exposing themselves to the rain, ran out to collect the frozen pearls.

- (a) How did Lencho feel when he saw his fields covered with the curtain of rain?
(b) What followed the rain?
(c) What did hailstone resemble?
(d) How did these new silver coins bring disaster to him?

- Ans.** (a) Lencho felt satisfied.
(b) A strong wind followed the rain.
(c) They resembled with silver coins.
(d) These new silver coins turned into hailstones which destroyed all his crops and ruined his hopes.

Q.8 All through the night, Lencho thought only of his one hope: the help of God, whose eyes, as he had been instructed, see everything, even what is deep in one's conscience. Lencho was an ox of a man, working like an animal in the fields but still, he knew how to write. The following Sunday, at daybreak, he began to write a letter which he himself would carry to town and place in the mail. It was nothing less than a letter to God.

- (a) What did Lencho think throughout the night?
- (b) What does 'Lencho was an ox of a man' imply?
- (c) Which line suggests that Lencho was literate?
- (d) What strange action did Lencho take?

Ans. (a) He thought of one hope—the help of God.
(b) He was very hardworking—he worked like an ox.
(c) "The following Sunday... he began to write a letter" This line suggests that Lencho was literate.
(d) Lencho's odd action was his letter addressed to God.

Q.9 The postmaster—a fat, amiable fellow also broke out laughing, but almost immediately he turned serious and tapping the letter on his desk, commented, "What faith! I wish I had the faith of the man who wrote this letter."

- (a) What was the postmaster's reaction to seeing the letter?
- (b) What did the postmaster wish?
- (c) What kind of person was the postmaster?
- (d) How did the postmaster help Lencho?

Ans. (a) He first laughed then became serious.
(b) To have as much faith in God as the writer who wrote the letter to God had.
(c) He was an amiable, kind, pleasant and friendly person.
(d) The postmaster asked his colleagues and friends to contribute some money as an act of charity. He himself contributed some and mailed it to Lencho.

◆ Very Short Answer Type Questions

Q.1 Where was the house' located ?

Ans. 'The House' was located on the top of a low hill.

Q.2 Why do you think it is called 'the' house and not 'a house'?

Ans. It is called 'the house' and not 'a house' because it was the only house in the entire valley.

Q.3 Why did Lencho keep gazing at the sky?

Ans. Lencho kept gazing at the sky because he wished for rain.

Q.4 How did Lencho feel when it started raining?

Ans. Lencho felt very happy.

Q.5 What was the effect of the rain on the crops?

Ans. His crops were destroyed because of the rain and the storm.

Q.6 Lencho had only one hope. What was it?

Ans. Lencho's only hope was help from God.

Q.7 Who was Lencho?

Ans. Lencho was a hard-working farmer.

Q.8 What had Lencho been doing throughout the morning?

Ans. He had been looking at the clouds in the northeast throughout the morning.

Q.9 What did Lencho's field need badly?

Ans. His fields needed heavy rain badly.

Q.10 What does Lencho call the rain-drops?

Ans. He calls the big rain-drops ten cent pesos and the small rain-drops five cent pesos.

Q.11 How did Lencho's field look after the hails had rained?

Ans. The field looked as if covered with salt.

Q.12 What was the effect of the hail storm on tile valley?

Ans. No crop or vegetation was left in the entire Valley.

Q.13 Who did Lencho write a letter to?

Ans. Lencho wrote a letter to God.

Q.14 How much money did Lencho demand from God?

Or

Why did Lencho write a letter to God?

Ans. In his letter, Lencho demanded one hundred pesos from God.

Q.15 How much money did Lencho receive from God?

Ans. He received only seventy pesos from God.

Q.16 Who sent the money to Lencho?

Ans. The postmaster sent the money to Lencho.

Q.17 Why did the post-master decide to answer Lencho's letter to God?

Ans. By doing so he wanted to protect Lencho's faith in God.

Q.18 How did Lencho feel when he counted the money in the envelope?

Ans. He got angry after counting the money in the envelope.

Q.19 Who does Lencho blame for the loss of thirty pesos in the envelope?

Ans. He blames the post-office employees for this loss.

Q.20 What does Lencho call the post-office employees?

Or

How did Lencho describe the post-office employees?

Ans. He calls them "a bunch of crooks."

◆ Answer the following questions in 30-40 words

Q.1 What were Lencho's feelings when he found the letter with money in it? What did he do after opening the letter?

Ans. Lencho was not at all surprised to see the money in the letter as he was fully confident about it. He knew that God will send money to him. On opening the letter he found seventy pesos instead of a hundred. So, he wrote another letter to God to send rest of the amount but now not through the mail as the post office employees were crooks.

Q.2 Whom did Lencho write a letter? What did he ask for?

Ans. When Lencho's annual crop was completely destroyed due to heavy rains and hailstorm and there was no one to help him during the crisis. At that time Lencho wrote a letter to God. He wrote the letter requesting Him to send 100 pesos so that he could sow his fields again till the next crop.

Q.3 Why does the postmaster send money to Lencho? Why does he sign the letter 'God'?

Ans. The postmaster was a kind, generous, helpful and God-fearing man. When he received the letter written to God asking for 100 pesos, he felt sympathetic towards Lencho. Hence, he decided to help Lencho. He gave a part of his salary and asked the other employees to help. He signed the letter 'God' in order to preserve the man's faith in God.

Q.4 How far would you agree that one's positivity can bring in a spark of brightness even in adverse circumstances?

Ans. It is absolutely true that optimism can bring about a spark of brightness even in adverse situations. It was Lencho's innocent optimism that eventually led to his getting seventy pesos. In fact, it was his positivity despite the hailstorm that he even wrote a letter to God in the first place. His hope finally triumphed.

Q.5 Was Lencho surprised to find a letter with money in it? Why/Why not?

Ans. Lencho was not at all surprised to receive the envelope with the money in it because he had utter faith in God. His unshakeable faith gave him firm confidence.

Q.6 What impression do you form the postmaster after reading the story 'A Letter to God'?

Ans. The postmaster was a kind, generous, helpful, amiable and God-fearing man. He was generous, as he helped Lencho with 70 pesos. He also wrote a reply to Lencho's letter in order to maintain his faith in God.

Q.7 Why was Lencho angry? What did he do?

Ans. Lencho had deep faith in God and hence wrote a letter to God asking for 100 pesos. But when he received 70 pesos instead of 100, he was angry. He wrote another letter to God asking him to send the rest of the money, but not through the post-office as they were a 'bunch of crooks'.

Q.8 Lencho calls the raindrops 'new coins'. Why does he call them so?

Ans. Lencho hoped to get good crops because of raindrops. He thought he would earn good money so he called them new coins. But raindrops soon turned into hailstones which destroyed all his crops and ruined his hopes.

- Q.9** Why were Lencho and his family in distress? Whom did he ask for help?
- Ans.** Lencho's crops were completely destroyed by the hailstones. He feared that he and his family would go hungry. He had no one to help but he had full faith in God whose eyes see everything. He wrote a letter to God asking for a hundred pesos to sow the crop and live until the next harvest.
- Q.10** "Now we're really going to get some water woman." Is Lencho sure that it is going to rain? Give a reason for your answer.
- Ans.** Yes. Lencho is sure that it is going to rain. He needs rain for his crops. He has been gazing at the sky since morning. He has perhaps seen some signs of coming rain. True to his prediction. It soon starts raining.
- Q.11** What are the raindrops compared to and why?
- Ans.** It starts raining. Lencho is very happy. He compares the big drops of rain to ten-cent pieces and the little ones to five-cent pieces. Lencho needs rain for a good harvest. If he has good crops, he will get money. That is why he compares the raindrops to coins.
- Q.12** Did the letter reach God? Why did the postmaster send a reply to Lencho?
- Ans.** No, the letter did not reach God. The postman saw the letter addressed to God. He took the letter to the postmaster. The postmaster did not want to shake Lencho's faith in God. So he sent a reply to Lencho. He sent seventy pesos to him
- Q.13** Why was Lencho angry when he received the letter?
- Ans.** Lencho had asked God to send him a hundred pesos. But when he opened the envelope he found only seventy pesos in it. He thought that the post-office employees had taken the rest of the money. So he became angry when he received the letter.
- Q.14** Lencho describes the post office employees as "a bunch of crooks."
- (i) Were they a bunch of crooks?
- (ii) How would you describe them?
- Ans.** Lencho thought that the post office employees had cheated him. So he calls them "a bunch of crooks." But they were not crooks. They were kind persons. They wanted to help Lencho. So they collected seventy pesos and sent the money to Lencho by mail.

◆ **Answer the following questions in 100-150 words**

- Q.1** Lencho received the money and a letter from God but still, he was not happy. Was it not in his attitude to be happy with what he achieved? Did he not know the pleasure of being grateful to others? Reflecting on the values required to lead a happy life.
- Ans.** Lencho had full faith in God and hence, had written a letter to God asking for 100 pesos. But when he received the money and a letter from God, he was not happy. It was not his attitude to be happy with what he received, nor was he ungrateful to God. He was angry because he had received 70 pesos instead of 100. He did not doubt God for it. He wrote another letter to God asking him to send the rest of the money but not through the post-office as they were a bunch of crooks. This shows that Lencho had full faith in God and was confident that his desire would be fulfilled. It was Lencho's innocent optimism that eventually led to his getting seventy pesos. Optimism and faith can lead to a happy life.

Q.2 The postmaster represents such people who still believe in helping others mention those values of the postmaster which you would like to emulate in yourself.

Ans. The postmaster was a kind, generous, helpful, amiable and God-fearing man. He received a letter from Lencho which was written to God asking for 100 pesos so that he could sow his fields again. The postman felt sympathetic towards Lencho. He decided to help Lencho. He gave up a part of his salary and asked all other employees to help. Even friends were made to contribute for a cause of charity and he managed to collect 70 pesos. He sent the money to Lencho along with a reply. He did so in order to preserve the man's faith in God. This shows the postmaster was a nice man at heart.

Q.3 "If you don't help me, my family and I will go hungry this year." Lencho had faith in God but he didn't manage to solve the problem by himself. Did he lack the courage to resolve his matter himself? What values did he lack ?

Ans. Lencho was a hardworking farmer. He was completely dependent upon the crops of his fields. His annual crop was completely destroyed due to heavy rains and hailstorm. In the entire village, there was no one to help him during the times of financial crisis. He had the firm belief in God and hence wrote a letter requesting Him to send 100 pesos so that he could sow his fields again till the next crop. This act did not prove that he lacked the courage to resolve his problem but shows that he did not have any option left for himself He had a firm belief in God. He was an ox of a man but lacked money to stand again.

Q.4 Show Lencho's faith and confidence in God with examples from the lesson.

Ans. Lencho had full faith in the help of God. The following sentences in the story tell us about it. 'Lencho thought only of his one hope: 'the help of God', whose eyes, as he had been instructed, see everything, even what is deep in one's conscience.'

Again, Lencho showed not the slightest surprise on seeing the money in the envelope—such was his confidence. But he became angry when he counted the money. 'God could not have made a mistake nor could he have denied Lencho what he had requested. The above facts from the text prove his deep faith and confidence in God.

Q.5 Give the character-sketch of Lencho.

Or

"I wish I had the faith of the man." Describe Lencho's character in the light of the above statement.

Ans. Lencho was a hardworking farmer. He laboured like an ox. He had good knowledge of farming and knew his crop needed a downpour to give him good yield.

Lencho had great faith in God. He knew how to read and write. He wrote a letter to God for help when his crops were totally ruined by hailstones.

He was a simple and innocent farmer. He could not reason out things. He blamed the post-office employees for cheating him of 30 pesos and called them 'A bunch of crooks'.

But Lencho was a caring head of the family. He got sad and worried that his family would have to go hungry.

Q.6 Why did Lencho write a letter to God? Who received the letter and what did he do?

Ans. Lencho was a hard- farmer. He was expecting a good harvest. But unfortunately, a hail storm came and destroyed his crop completely. Now he had nothing to support the family. He had no money to purchase the seed for sowing. But he had a firm faith in God. He believed that God would help him. He was a simple man. He Wrote a letter to God. He asked God to send him a hundred pesos. He wanted this money in order to sow seed again and to live until the next harvest season.

Lencho went to the town and pasted the letter. At the post-office, a postman took out the letter from the letterbox. He read the address on it and had a good laugh. He showed the letter to the postmaster the postmaster was greatly impressed by the faith of Lencho. He did not want to shake Lencho's faith in God. He collected money from his employees. He put this money into an envelope and addressed it to Lencho.

Q.7 (i) What did the postmaster need to answer the letter? How did he collect it?

(ii) How did Lencho react to help?

Ans. (i) Lencho's crop had been destroyed. He needed God's help. So he wrote a letter to God. He posted the letter. At the post-office, a postman took the letter out of the letterbox. He laughed at reading the address. He showed the letter to the postmaster. The postmaster also laughed. But he praised Lencho's firm faith in God. He did not want to shake this faith. He was very kind. He decided to help Lencho. He and the post-office employees collected some money. The postmaster gave a part of his salary. They put the money into an envelope and addressed it to Lencho.

(ii) The next Sunday Lencho came to the post-office. He asked if there was any letter for him. The postman gave him the envelope. Lencho opened the letter. He found that the money was less than what he had requested for. He thought that God could not have made a mistake. He wrote another letter to God. He asked God to send him the rest of the money. But he should not send it through the mail as the post-office employees were a bunch of crooks.

Q.8 How do you think the postmaster felt when he received Lencho's second letter? What do you think he did?

Ans. When Lencho opened the letter, he found only seventy pesos in it. He thought that God could not make a mistake. Perhaps the post office employees had cheated him. He wrote another letter to God. He wrote that the post office employees were a bunch of crooks. The story does not tell us what the postmaster felt when he received the second letter. Perhaps he felt shocked. It is possible that he realized that sometimes even good intentions are misunderstood. I think he met Lencho and explained everything to him. He told him that the post-office employees were not a bunch of crooks. In fact, they were kind and helpful. They had collected money to help him.

Q.9 Write the story of Lencho's faith in God.

Or

Write a brief summary of the story 'A Letter to God'.

Ans. Lencho was a simple farmer. He was very hard-working. But one year, his harvest was completely destroyed by the hailstorm. He had firm faith in God. He wrote a letter to God asking for a hundred pesos. The postmaster saw the letter. He decided to help Lencho. He collected money from his employees. He gave some part of his own salary also. But the money was less than what Lencho had asked for. The postmaster put the money into an envelope and addressed it to Lencho. Next Sunday Lencho came to collect his letter. When he counted the money he became angry. He wrote another letter to God. He asked God to send him the rest of the money. But he asked God not to send the money through the mail as the employees of the post-office were a bunch of crooks.

Q.10 Lencho described the post-office employees as a 'bunch of crooks'. Were they really a bunch of crooks? How would you describe them?

Ans. A crook is a person who cheats others. He earns his living by dishonest means. Lencho requested God for a hundred pesos. He received a letter in the mail. When he opened it he found seventy pesos in it. He thought that the post-office employees had taken the rest of thirty pesos. So he called them a bunch of crooks. But in fact, they were kind and generous people. They did not want to shake Lencho's faith in God. So they raised money to help him. But they could not raise a hundred pesos. So they put seventy pesos in an envelope and addressed it to Lencho. The post-office employees were good people. They did an act of kindness and Charity. It was wrong for Lencho to call them a bunch of crooks

Q.11 Why did Lencho need God's help?

Ans. Lencho was a simple farmer. He was very hard-working. His crops had always been good. One year, he wished that there should be some rain so that his crop would be better. Lencho was sure that the rain would come. In the evening it started raining. But soon the rain changed into a hailstorm. The hails fell on the house, the garden, the hillside and the corn-field. The field looked white as if it had been covered with salt. No leaves were left on the trees. The flowers were gone from the plants. Lencho's crop was completely destroyed. His heart was filled with sorrow. But he had faith in God. He was sure that God would help him. He wanted God's help for sowing seed and for living until the next harvest.