



JEE Advanced Exam 2026

(Paper & Answers)

Date : 17 / 05 / 2026

PAPER-2

MATHEMATICS

SECTION – 1 (Maximum Mark : 12)

- This section contains FOUR (04) questions.
- Each question has **FOUR** options (A), (B), (C) and (D). **ONLY ONE** of these four options is the correct answer.
- For each question, choose the option corresponding to the correct answer.
- Answer to each question will be evaluated according to the following marking scheme:

Full Marks	: +3	If ONLY the correct option is chosen;
Zero Marks	: 0	If none of the option is chosen (i.e. the question is unanswered);
Negative Marks	: -1	In all other cases.

- Q.1** Let \vec{a}, \vec{b} be two vectors, and let P, Q and R be the points with position vectors \vec{a}, \vec{b} and $\vec{a} + \vec{b}$, respectively, with respect to the origin O. If $|\vec{a} + \vec{b}| = \sqrt{21}$, $|\vec{a} - \vec{b}| = 3$, and \vec{a} and $(\vec{a} - \vec{b})$ are perpendicular to each other, then the area of the triangle OPR is
- (A) $\sqrt{3}$ (B) $\frac{\sqrt{3}}{2}$ (C) $\frac{3\sqrt{3}}{2}$ (D) $\frac{3}{2}$

Ans. [C]

Sol. Given $|\vec{a} + \vec{b}| = \sqrt{21}$ and $|\vec{a} - \vec{b}| = 3$

On squaring and adding $|\vec{a}|^2 + |\vec{b}|^2 = 15 \Rightarrow \vec{a} \cdot \vec{b} = 3 \quad \dots(i)$

Again as $\vec{a} \perp \vec{a} - \vec{b} \Rightarrow \vec{a} \cdot (\vec{a} - \vec{b}) = 0$

$\Rightarrow |\vec{a}|^2 = \vec{a} \cdot \vec{b} = 3 \Rightarrow |\vec{b}|^2 = 12$ from (i)

As we know $(\vec{a} \cdot \vec{b})^2 + |\vec{a} \times \vec{b}|^2 = |\vec{a}|^2 |\vec{b}|^2$

$\Rightarrow |\vec{a} \times \vec{b}| = \sqrt{36 - 9} = 3\sqrt{3}$

$\Rightarrow \text{Area of } \Delta OPR = \frac{1}{2} |\vec{a} \times \vec{b}| = \frac{3\sqrt{3}}{2}$

- Q.2** Let T be the tangent to the parabola $y^2 = 16x$ at the point (64, 32). Let L be the tangent to the same parabola at another point (x_1, y_1) on the parabola. If L and T are perpendicular to each other, then the distance between the point (x_1, y_1) and the focus of the parabola, is

- (A) $\frac{15}{4}$ (B) 4 (C) $\frac{17}{4}$ (D) 5

**Ans.** [C]**Sol.** General point on Parabola $y^2 = 16x$ is $(4t^2, 8t)$ $\Rightarrow t = 4$ for the point $P(64, 32)$ (let)Focal distance of other point = $SQ = a + \frac{4}{t^2}$

$$= 4 + \frac{4}{16} = \frac{17}{4}$$

Q.3 Let $y: (-\infty, \infty) \rightarrow (0, \infty)$ be the solution of the differential equation $\frac{dy}{dx} = \frac{e^{5x}y^3 + y^3}{e^x + e^xy^4}$ satisfying $y(0) = \frac{1}{\sqrt{2}}$.Then the value of $y(\log_e 2)$ is

(A) $\sqrt{\frac{5+\sqrt{35}}{2}}$ (B) $\sqrt{\frac{7+\sqrt{53}}{2}}$ (C) $\frac{7+\sqrt{53}}{2}$ (D) $\frac{5+\sqrt{35}}{2}$

Ans. [B]**Sol.** On solving we get $\frac{dy}{dx} = \frac{(e^{5x} + 1)y^3}{e^x(1 + y^4)}$ (variable separable form)

$$\Rightarrow \int \left(\frac{1}{y^3} + y \right) dy = \int (e^{4x} + e^{-x}) dx$$

$$\Rightarrow -\frac{1}{2y^2} + \frac{y^2}{2} = \frac{e^{4x}}{4} - e^{-x} + c \dots (1)$$

As $y(0) = \frac{1}{\sqrt{2}} \Rightarrow c = 0$

Again on putting $x = \log_e 2$ in (1). We get

$$-\frac{1}{2y^2} + \frac{y^2}{2} = 4 - \frac{1}{2} \Rightarrow y^4 - 7y^2 - 1 = 0$$

$$\Rightarrow y = \sqrt{\frac{7+\sqrt{53}}{2}} \quad \left(\text{since, } \frac{7-\sqrt{53}}{2} < 0 \right)$$

Q.4 The value of the definite integral $\int_0^2 \frac{1}{3^x + 3} dx$ is

(A) $\frac{1}{2}$ (B) $\frac{1}{3}$ (C) $\frac{\log_e 3}{3}$ (D) $\frac{\log_e 3}{2}$

Ans. [B]

Sol. $I = \int_0^2 \frac{1}{3 + 3^x} dx \dots (1)$

$$I = \int_0^2 \frac{1}{3 + 3^{2-x}} dx \dots (2)$$

Adding (1) and (2)

$$2I = \int_0^2 \left(\frac{1}{3+3^x} + \frac{3^x}{3(3+3^x)} \right) dx$$

$$2I = \int_0^2 \left(\frac{3+3^x}{3(3+3^x)} \right) dx$$

$$2I = \int_0^2 \frac{1}{3} dx$$

$$2I = \frac{1}{3} [x]_0^2$$

$$2I = \frac{2}{3}$$

$$\Rightarrow I = \frac{1}{3}$$

\Rightarrow Option (B) is correct.

SECTION – 2 (Maximum Mark : 20)

- This section contains **Five (05)** questions
- Each question has **FOUR** options (A), (B), (C) and (D). **ONE OR MORE THAN ONE** of these four option(s) is (are) correct answer(s).
- For each question, choose the option(s) corresponding to (all) the correct answer(s).
- Answer to each question will be evaluated **according to the following marking scheme** :
 - Full Marks : +4 **ONLY** If (all) the correct option(s) is (are) chosen.
 - Partial Marks : +3 If all the four options are correct but **ONLY** three options are chosen.
 - Partial Marks : +2 If three or more options are correct but **ONLY** two options are chosen, both of which are correct.
 - Partial Marks : +1 If two or more options are correct but **ONLY** one option is chosen and it is a correct option.
 - Zero Marks : 0 If none of the options is chosen (i.e. the question is unanswered);
 - Negative Marks : -1 In all other cases.
- For example, in a question, if (A), (B) and (D) are the **ONLY** three options corresponding to correct answers, than
 - choosing **ONLY** (A), (B) and (D) will get +4 marks;
 - choosing **ONLY** (A) and (B) will get +2 marks;
 - choosing **ONLY** (A) and (D) will get +2 marks;
 - choosing **ONLY** (B) and (D) will get +2 marks;
 - choosing **ONLY** (A) will get +1 mark;
 - choosing **ONLY** (B) will get +1 mark;
 - choosing **ONLY** (D) will get +1 mark;
 - choosing no option (i.e. the question is unanswered) will get 0 marks and
 - choosing any other combination of option will get -1 marks.



Q.5 Let \mathbb{R} denote the set of all real numbers. Consider the polynomial function $f : \mathbb{R} \rightarrow \mathbb{R}$ defined by

$$f(x) = \frac{d^{10}}{dx^{10}} \left((x^2 - 1)^{10} \right), \text{ for all } x \in \mathbb{R}$$

Here $\frac{d^{10}}{dx^{10}} \left((x^2 - 1)^{10} \right)$ is the 10th order derivative of the function $(x^2 - 1)^{10}$.

Then which of the following statements is (are) TRUE?

(A) The coefficient of x^8 in the polynomial $f(x)$ is $(-10) \left(\frac{18!}{8!} \right)$

(B) The value of $f(1) + f(-1)$ is equal to $10!2^{11}$

(C) The degree of the polynomial $f(x)$ is 10

(D) The constant term of the polynomial $f(x)$ is $-\left(\frac{10!}{5!} \right)$

Ans. [A,B,C]

Sol. Let $g(x) = (x^2 - 1)^{10}$.

$$= {}^{10}C_0 x^{20} - {}^{10}C_1 x^{18} + {}^{10}C_2 x^{16} - \dots + {}^{10}C_{10}$$

$$\Rightarrow f(x) = {}^{10}C_0 \cdot 20 \cdot 19 \dots 11 x^{10} - {}^{10}C_1 \cdot 18 \cdot 17 \dots 9 x^8 + {}^{10}C_2 \cdot 16 \cdot 15 \dots 7 x^6 - \dots - {}^{10}C_5 \cdot 10 \cdot 9 \cdot 8 \dots 21$$

(A) Coefficient of x^8 is $(-10) \left(\frac{18!}{8!} \right)$

(B) $f(1) = f(-1)$ (as $(x^2 - 1)$ is even function)

\Rightarrow even time derivative will be even functions.

(C) $f(x)$ is degree 10 polynomial

(D) Constant term is $\frac{-(10!)^2}{5!5!}$

Q.6 Let a, b, c be positive integers in arithmetic progression such that the equation $ax^2 + bx + c = 0$ has only integer solutions. Then which of the following statements is (are) TRUE?

(A) $c - b$ is an integer multiple of a

(B) Both the roots of the equation $ax^2 + bx + c = 0$ are odd integers

(C) If $c = 15$, then $ab = 8$

(D) If $b = 8$, then $x = 3$ is a root of the equation $ax^2 + bx + c = 0$

Ans. [A,B,C]

Sol. Let α, β be roots of the equation.

$$\alpha + \beta = \frac{-b}{a} = k_1 \Rightarrow b = -ak_1 \quad (k_1 \in \mathbb{I})$$

$$\alpha\beta = \frac{c}{a} = k_2 \Rightarrow c = ak_2 \quad (k_2 \in \mathbb{I})$$

$$\Rightarrow c - b = a(k_1 + k_2)$$

Equation is $x^2 - k_1x + k_2 = 0$

Where $-2ak_1 = ak_2 + a \Rightarrow k_2 = -2k_1 - 1$

Product of roots is odd \Rightarrow both roots are odd.

If $c = 15$, then roots can be either $-1, -15$ or $-3, -5$.

If roots are $-1, -15 \Rightarrow b = 16 \Rightarrow a = 17$

So, quadratic will be $17x^2 + 16x + 15 = 0$ which is contradiction as its roots are not $-1, -15$

Roots can only be $-3, -5$ in which case equation will be $x^2 + 8x + 15 = 0$

The quadratic is $x^2 - k_1x - 2k_1 - 1 = 0$

Putting $x = 3 \Rightarrow 8 - 5k_1 = 0 \Rightarrow k_1 = 5/8$ which is a contradiction so 3 can never be a root of the quadratic.

Q.7 Let L be the straight line joining the points $P(1, 2, -1)$ and $Q(2, 3, 1)$. Let S be the foot of the perpendicular drawn from the point $R(4, -1, 5)$ to the line L . Another line passing through R intersects L at a point T such that the point S divides the line segment PT internally in the ratio $|PS| : |ST| = 1 : 2$, where $|PS|$ and $|ST|$ are the lengths of the line segments PS and ST , respectively.

Then which of the following statements is (are) TRUE ?

(A) The orthocentre of the triangle PRT is $\left(\frac{23}{5}, -4, \frac{31}{5}\right)$

(B) The orthocentre of the triangle PRT is $(4, 3, 5)$

(C) The area of the triangle PRT is $6\sqrt{5}$

(D) The area of the triangle PRT is $18\sqrt{5}$

Ans. [A, D]

Sol. Equation of line $\frac{x-1}{1} = \frac{y-2}{1} = \frac{z+1}{2} = \lambda$

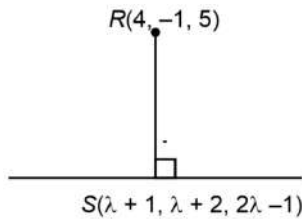

Hence,

$$(\lambda - 3) \times 1 + (\lambda + 3) \times 1 + (2\lambda - 6) \times 2 = 0$$

$$\lambda - 3 + \lambda + 3 + 4\lambda - 12 = 0$$

$$6\lambda - 12 = 10 \Rightarrow \lambda = 2$$

$$\Rightarrow S(3, 4, 3)$$

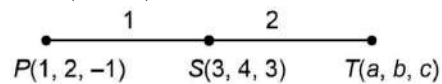

$$\frac{a+2}{3} = 3, \frac{b+4}{3} = 4, \frac{c-2}{3} = 3$$

$$a = 7, b = 8, c = 11$$

$$T(7, 8, 11)$$

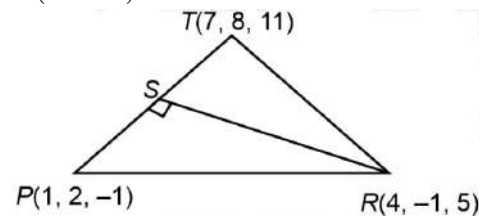

Area of triangle PRT

$$= \frac{1}{2}(PT)(RS) = \frac{1}{2} \times 6\sqrt{6} \times \sqrt{30} = 18\sqrt{5} \Rightarrow \text{Option (D) is correct}$$

(A)

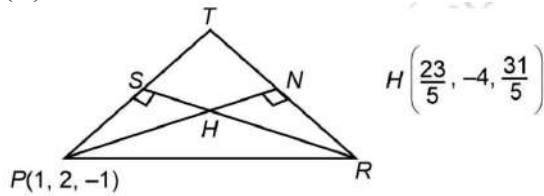

$$\text{Equation of RS} \equiv \frac{x-4}{1} = \frac{y+1}{-5} = \frac{z-5}{2}$$

\Rightarrow H lies on RS

Direction ratio of

$$\overline{PH} \equiv \left(\frac{23}{5} - 1, -4 - 2, \frac{31}{5} + 1 \right) = \left(\frac{18}{5}, -6, \frac{36}{5} \right)$$

$$\text{D.R. of RT} \equiv (-3, -9, -6)$$

$$\overline{PH} \cdot \overline{RT} = -3 \left(\frac{18}{5} \right) - 9(-6) - 6 \left(\frac{36}{5} \right)$$

$$= \frac{-54}{5} + 54 - \frac{216}{5} = 0$$

Hence, H is orthocentre

Option (A) is correct

Q.8 Let $y = f(x)$ be the real valued function defined on the interval $(0, \infty)$, satisfying $y(1) = 0$ and the differential equation $x \frac{dy}{dx} = y - x^3$. Then which of the following statements is (are) TRUE?

(A) The function f has a local minimum at $x = \frac{1}{\sqrt{3}}$

(B) The function f has a local maximum at $x = \frac{1}{\sqrt{3}}$

(C) The function f is increasing in the interval $(1, 2)$

(D) If $g(x) = 4x^3 - 5x^2 + \frac{3}{2}x$ for $x > 0$, then the number of elements in the set $\{x \in (0, \infty) : f(x) = g(x)\}$ is 2

Ans. [B,D]

Sol. $x \frac{dy}{dx} = y - x^3$

$$\Rightarrow \frac{dy}{dx} - \frac{y}{x} = -x^2$$

$$\Rightarrow \frac{d}{dx} \left(\frac{y}{x} \right) = -x$$

$$\Rightarrow \frac{y}{x} = \frac{-x^2}{2} + c$$

$$y(1) = 0 \Rightarrow c = \frac{1}{2}$$

$$\Rightarrow f(x) = \frac{x - x^3}{2}$$

$$\Rightarrow f'(x) = \frac{1 - 3x^2}{2}$$

$$\Rightarrow f'(x) > 0 \forall x \in \left(\frac{-1}{\sqrt{3}}, \frac{1}{\sqrt{3}} \right) \text{ and } f'(x) < 0 \forall x \in \left(-\infty, \frac{-1}{\sqrt{3}} \right) \cup \left(\frac{1}{\sqrt{3}}, \infty \right)$$

$$\Rightarrow f(x) \text{ has a local maximum at } x = \frac{1}{\sqrt{3}}$$

Also, $f(x) = g(x)$

$$\Rightarrow \frac{x - x^3}{2} = 4x^3 - 5x^2 + \frac{3x}{2}$$

$$\Rightarrow 9x^2 - 10x + 2 = 0, (x > 0)$$

$$\Rightarrow x = \frac{10 \pm \sqrt{28}}{18}$$

\Rightarrow Number of elements in the set is 2.

Q.9 Let \mathbb{R} denote the set of all real numbers and let $i = \sqrt{-1}$.

Consider the matrices $S = \begin{bmatrix} 0 & -1 \\ 1 & 0 \end{bmatrix}$ and $T = \begin{bmatrix} 1 & 1 \\ 0 & 1 \end{bmatrix}$

Let a, b, c, d be real numbers such that $ST = \begin{bmatrix} a & b \\ c & d \end{bmatrix}$

Let $H = \{x + iy : x, y \in \mathbb{R} \text{ and } y > 0\}$. Then which of the following statements is (are) TRUE?

(A) $\frac{b + ia}{d + ic} = i$

(B) If $\omega = \frac{-1 + i\sqrt{3}}{2}$, then $\frac{a\omega + b}{c\omega + d} = \omega$

(C) If m is an integer greater than 2 such that $(ST)^2 = (ST)^m$, then m is an integer multiple of 8

(D) If $z \in H$, then $\frac{az + b}{cz + d} \in H$

Ans. [B,D]

Sol. $S = \begin{bmatrix} 0 & -1 \\ 1 & 0 \end{bmatrix}, T = \begin{bmatrix} 1 & 1 \\ 0 & 1 \end{bmatrix}$

$$\Rightarrow ST = \begin{bmatrix} 0 & -1 \\ 1 & 1 \end{bmatrix} = \begin{bmatrix} a & b \\ c & d \end{bmatrix}$$

$$\Rightarrow (ST)^3 = \begin{bmatrix} 0 & -1 \\ -1 & 0 \end{bmatrix}$$

$$\Rightarrow a = 0, b = -1, c = 1, d = 1$$

(A) $\frac{b + ia}{d + ic} = \frac{-1}{1 + i} = -\frac{1}{2} + \frac{i}{2}$

(B) $\frac{a\omega + b}{c\omega + d} = \frac{-1}{1 + \omega} = \omega$



(C) $(ST)^6 = I$

$\Rightarrow (ST)^{6k+2} = (ST)^2, k \in \mathbb{N}$

$\Rightarrow m = 6k + 2, k \in \mathbb{N}$

(D) If $z \in H$, then $-\bar{z} \in H$

$\frac{az + b}{cz + d} = \frac{-1}{z + 1} = \frac{-(\bar{z} + 1)}{|z + 1|^2} \in H$

SECTION – 3 (Maximum Marks: 20)

- This section contains **Five (05)** questions.
- The answer to each question is a **NUMERICAL VALUE**.
- For each question, enter the correct numerical value corresponding to the answer in the designated place using the mouse and the on-screen virtual numeric keypad.
- If the numerical value has more than two decimal places, truncate/round-off the value to **TWO** decimal places.
- Answer to each question will be evaluated **according to the following marking scheme:**

Full Marks	: +4	If ONLY the correct numerical value is entered in the designated place;
Zero Marks	: 0	In all other cases.

Q.10 Let \mathbb{N} denote the set of all positive integers. Consider the sets

$A = \{1, 2, 3, 4, 5\}$ and $B = \{1, 2, 3, 4, 5, 6, 7\}$

Let S be the set of all functions $f : A \rightarrow B$ such that $f(2) \neq 2$ and $f(4) \neq 4$.

Consider the set

$T = \{f \in S : \text{there exists a function } g : B \rightarrow \mathbb{N} \text{ such that } g(f(x)) = 2^x \text{ for all } x \in A\}$.

Then the number of elements in the set T is _____ .

Ans. [1860.00]

Sol. $g(f(x))$ is one-one as 2^x is one one $\forall x \in A$

$\therefore f(x)$ must be one-one

Let $A = \{f \in S : f(2) = 2\}$

$B = \{f \in S, f(4) = 4\}$

$n(T) = n(\bar{A} \cap \bar{B})$

$= n(U) - (n(A) + n(B) - n(A \cap B))$

$= 2520 - (360 + 360 - 60)$

$= 1860$

Q.11 A bookshelf contains 6 distinct books of Mathematics and 5 distinct books of Physics. From these 11 books, 6 books are chosen at random. Let X be the absolute value of the difference between the number of Mathematics books chosen and the number of Physics books chosen. If α is the mean of the random variable X , then the value of 77α is _____ .

Ans. [100.00]

Sol. $X_0 = 0, P_0 = \frac{{}^6C_3 {}^5C_3}{{}^{11}C_6} = \frac{200}{462}$

$X_1 = 2, P_1 = \frac{{}^6C_4 {}^5C_2 + {}^6C_2 {}^5C_4}{{}^{11}C_6} = \frac{225}{462}$

$$X_2 = 4, P_2 = \frac{{}^6C_5 {}^5C_1 + {}^6C_1 {}^5C_5}{{}^{11}C_6} = \frac{36}{462}$$

$$X_3 = 6, P_3 = \frac{{}^6C_6 {}^5C_0}{{}^{11}C_6} = \frac{1}{462}$$

$$\alpha = \sum p_i x_i = \frac{600}{462}$$

$$77\alpha = 100$$

Q.12 Consider a data consisting of 10 observations x_1, x_2, \dots, x_{10} , whose mean is 5 and variance is 7. If the mean and the variance of the first 8 observations x_1, x_2, \dots, x_8 are 4 and 3.5, respectively, and $x_9 < x_{10}$, then the value of $3x_9 + 2x_{10}$ is _____ .

Ans. [44.00]

Sol.
$$\frac{x_1 + x_2 + x_3 + \dots + x_8 + x_9 + x_{10}}{10} = 5$$

$$x_1 + x_2 + x_3 + \dots + x_8 = 32$$

$$\Rightarrow x_9 + x_{10} = 50 - 32$$

$$\Rightarrow x_9 + x_{10} = 18$$

Now,

$$\sum_{i=1}^{10} \frac{x_i^2}{10} - 25 = 7$$

$$\sum_{i=1}^{10} x_i^2 = 320$$

$$\text{and } \sum_{i=1}^8 \frac{x_i^2}{8} - 16 = 3.5$$

$$\sum_{i=1}^8 x_i^2 = 156$$

$$\Rightarrow x_9^2 + x_{10}^2 = 320 - 156$$

$$\Rightarrow x_9^2 + x_{10}^2 = 164$$

$$\Rightarrow (x_9 + x_{10})^2 = x_9^2 + x_{10}^2 + 2x_9x_{10}$$

$$\Rightarrow x_9x_{10} = 80$$

$$\Rightarrow x_9 = 8, x_{10} = 10$$

$$\Rightarrow 3x_9 + 2x_{10} = 44$$

Q.13 Consider the ellipse E given by $\frac{x^2}{18} + \frac{y^2}{12} = 1$. Let H be the hyperbola whose eccentricity is the reciprocal of the eccentricity of E and whose foci are the same as that of E. Let P and Q be the points of intersection of H and the parabola $\sqrt{5}y = x^2$ in the first quadrant. Let d be the distance between P and Q.

If a and b are the integers such that $d^2 = a + b\sqrt{5}$, then the value of $a - b$ is _____ .

Ans. [18.00]

Sol.
$$\frac{x^2}{18} + \frac{y^2}{12} = 1$$

$$e_E = \sqrt{1 - \frac{b^2}{a^2}} = \sqrt{1 - \frac{12}{18}} = \frac{1}{\sqrt{3}}$$

$$\therefore \text{foci is } (\pm\sqrt{6}, 0). \quad e_H = \frac{1}{e_E} = \sqrt{3}$$

$$\text{Let equation of hyperbola is } \frac{x^2}{A^2} - \frac{y^2}{B^2} = 1$$

$$\text{Foci is } (\pm Ae_H, 0) = (\pm\sqrt{6}, 0)$$

$$\text{So, } A^2 = 2$$

$$B^2 = A^2 (e_H^2 - 1) = 4$$

$$\therefore \text{Equation of H: } \frac{x^2}{2} - \frac{y^2}{4} = 1$$

$$\text{Now, } x^2 = \sqrt{5}y \text{ putting this in equation of hyperbola, } \frac{\sqrt{5}y}{2} - \frac{y^2}{4} = 1$$

$$2\sqrt{5}y - y^2 = 4 \Rightarrow y^2 - 2\sqrt{5}y + 4 = 0$$

$$y = \frac{2\sqrt{5} \pm \sqrt{(2\sqrt{5})^2 - 4(1)(4)}}{2} = \sqrt{5} \pm 1$$

$$\text{so, } y_1 = \sqrt{5} + 1, \quad y_2 = \sqrt{5} - 1$$

$$x_1^2 = \sqrt{5}(\sqrt{5} + 1) = 5 + \sqrt{5}$$

$$x_2^2 = 5 - \sqrt{5}$$

$$d^2 = (x_1 - x_2)^2 + (y_1 - y_2)^2$$

$$\text{Now, } (y_1 - y_2)^2 = [(\sqrt{5} + 1) - (\sqrt{5} - 1)]^2 = 4$$

$$(x_1 - x_2)^2 = x_1^2 + x_2^2 - 2x_1x_2$$

$$= 10 - 2(2\sqrt{5}) = 10 - 4\sqrt{5}$$

$$d^2 = 14 - 4\sqrt{5}$$

$$\therefore a - b = 14 - (-4) = 18$$

Q.14 For a real number α , let $[\alpha]$ denote the greatest integer less than or equal to α . For a finite set S, let $|S|$ denote the number of elements in the set S.

Consider the functions $f : (-3, 3) \rightarrow (-\infty, \infty)$ and $g : (-3, 3) \rightarrow (-\infty, \infty)$ defined by

$$f(x) = [x^3] \log_e (1 + \sin^2 (\pi(x - [x]))) \text{ and } g(x) = x^3 \sin^2 (\pi \log_e (1 + x - [x]))$$

Let $A = \{x \in (-3, 3) : f \text{ is discontinuous at } x\}$ and $B = \{x \in (-3, 3) : g \text{ is discontinuous at } x\}$.

Then the value of $|A| + 2|B| - |A \cap B|$ is

Ans. [56.00]

Sol. $f(x) = [x^3] \ln(1 + \sin^2 (\pi\{x\}))$, $x \in (-3, 3)$

$\Rightarrow f(x)$ is discontinuous at those points where x^3 is integer except those points where x is integer.

$$\Rightarrow |A| = 48$$

$$g(x) = x^3 \sin^2 (\pi \ln(1 + \{x\})), \quad x \in (-3, 3)$$



$$\begin{aligned} \Rightarrow g(x) \text{ is discontinuous at } x \in \{-2, -1, 1, 2\} \\ \Rightarrow |B| = 4 \\ \Rightarrow |A \cap B| = 0 \\ \Rightarrow |A| + 2|B| - |A \cap B| = 56 \end{aligned}$$

SECTION – 4 (Maximum Marks: 8)

- This section contains **Two (02)** questions.
- There are **TWO (02)** questions corresponding to each question stem.
- The answer to each question is a **NUMERICAL VALUE**.
- For each question, enter the correct numerical value corresponding to the answer in the designated place using the mouse and the on-screen virtual numeric keypad.
- If the numerical value has more than two decimal places, **truncate/round-off** the value to **TWO** decimal places.
- Answer to each question will be evaluated **according to the following marking scheme:**

Full Marks	: +2	If ONLY the correct numerical value is entered in the designated place;
Zero Marks	: 0	In all other cases.

Question Stem for Question Nos. 15 and 16

Consider the curve C_1 given by $y = e^{-x}$ for $x \in [0, 10\pi]$ and the curve C_2 given by $y = e^{-x}(\sin x + \cos x)$ for $x \in [0, 10\pi]$. Let n be the total number of points of intersection of the curves C_1 and C_2 . Suppose that $\alpha_1, \alpha_2, \dots, \alpha_n \in [0, 10\pi]$ are the x -coordinates of the points of intersection of the curves C_1 and C_2 such that $\alpha_1 < \alpha_2 < \dots < \alpha_n$.

Q.15 The value of n is ____ .

Ans. [11.00]

Sol. $C_1 : y = e^{-x}, C_2 : y = e^{-x}(\sin x + \cos x)$

For $x \in [0, 10\pi]$

Total number of points of intersection of C_1 and $C_2 = 11$

Where $\alpha_1 = 0, \alpha_2 = \frac{\pi}{2}, \alpha_3 = 2\pi, \alpha_4 = \frac{5\pi}{2}, \dots, \alpha_9 = 8\pi, \alpha_{10} = \frac{17\pi}{2}, \alpha_{11} = 10\pi$

$\Rightarrow n = 11$

Q.16 Let β be the area of the region enclosed between the curves C_1, C_2 , and the lines $x = \alpha_1$ and $x = \alpha_4$. Then the

value of $-\frac{1}{\pi} \log_e \left(\beta - 2e^{-\frac{\pi}{2}} \right)$ is ____ .

Ans. [02.50]

Sol. Area of the region is β .

$$\Rightarrow \beta = \int_0^{\frac{5\pi}{2}} \left| e^{-x}(\sin x + \cos x) - e^{-x} \right| dx$$

$$\Rightarrow \beta = \int_0^{\pi/2} e^{-x}(\sin x + \cos x) - e^{-x} dx +$$

$$\int_{\pi/2}^{2\pi} \left(e^{-x} - e^{-x}(\sin x + \cos x) \right) dx +$$

$$\int_{2\pi}^{5\pi/2} (e^{-x} (\sin x + \cos x) - e^{-x}) dx$$

$$\Rightarrow \beta = 2e^{-\pi/2} + e^{-5\pi/2}$$

$$\Rightarrow -\frac{1}{\pi} \ln(\beta - 2e^{-\pi/2}) = -\frac{1}{\pi} \times \left(-\frac{5\pi}{2}\right)$$

$$= \frac{5}{2} = 2.50$$

Question Stem for Question Nos. 17 and 18

Consider the ellipses given by $x^2 + 4y^2 = 1$ and $4x^2 + y^2 = 1$

Q.17 Let P be the point in the first quadrant where the given ellipses intersect. If θ is the acute angle between the tangents to the given ellipses at the point P, then the value of $4 \tan \theta$ is _____ .

Ans. [07.50]

Sol. $E_1 : x^2 + 4y^2 = 1$, $E_2 : 4x^2 + y^2 = 1$

Intersection point in 1st quadrant is

$$P\left(\frac{1}{\sqrt{5}}, \frac{1}{\sqrt{5}}\right) \text{ tangent to } E_1 \text{ at point P is } x \cdot \frac{1}{\sqrt{5}} + 4y \cdot \frac{1}{\sqrt{5}} = 1$$

$$\Rightarrow x + 4y = \sqrt{5}, m_1 = -\frac{1}{4}$$

$$\text{Tangent to } E_2 \text{ at point P is } 4x \cdot \frac{1}{\sqrt{5}} + y \cdot \frac{1}{\sqrt{5}} = 1$$

$$\Rightarrow 4x + y = \sqrt{5}, m_2 = -4$$

$$\Rightarrow \tan \theta = \left| \frac{m_1 - m_2}{1 + m_1 m_2} \right| = \left| \frac{-\frac{1}{4} + 4}{1 + \frac{1}{4} \times 4} \right| = \frac{15}{8}$$

$$\Rightarrow 4 \tan \theta = \frac{15}{2} = 07.50$$

Q.18 If α is the area of the common region that lies inside both the given ellipses, then the value of $\cot \alpha$ is _____ .

Ans. [00.75]

Sol. $\alpha = 4 \times \frac{1}{\sqrt{5}} \times \frac{1}{\sqrt{5}} + 8 \int_{\frac{1}{\sqrt{5}}}^{\frac{1}{2}} \sqrt{1 - 4x^2} dx$

$$= \frac{4}{5} + 8 \left[\frac{x}{2} \sqrt{1 - 4x^2} + \frac{1}{4} \sin^{-1}(2x) \right]_{\frac{1}{\sqrt{5}}}^{\frac{1}{2}}$$



$$\begin{aligned} &= \frac{4}{5} + 8 \left[\frac{\pi}{8} - \frac{1}{2\sqrt{5}} \times \frac{1}{\sqrt{5}} - \frac{1}{4} \sin^{-1} \left(\frac{2}{\sqrt{5}} \right) \right] \\ &= \frac{4}{5} + \pi - \frac{4}{5} - 2 \sin^{-1} \left(\frac{2}{\sqrt{5}} \right) \\ &= \pi - 2 \sin^{-1} \left(\frac{2}{\sqrt{5}} \right) = \sin^{-1} \left(\frac{4}{5} \right) = \cot^{-1} \left(\frac{3}{4} \right) \\ \Rightarrow \cot \alpha &= \frac{3}{4} = 00.75 \end{aligned}$$

PHYSICS

SECTION – 1 (Maximum Mark : 12)

- This section contains **FOUR (04)** questions.
- Each question has four options (A), (B), (C) and (D). **Only one** of these four option is the correct answer.
- For each question, choose the option corresponding to the correct answer.
- Answer to each question will be evaluated according to the following marking scheme :

Full Marks	: +3	If ONLY the correct option is chosen;
Zero Marks	: 0	If none of the option is chosen (i.e. the question is unanswered);
Negative Marks	: -1	In all other cases.

- Q.1** A metal wire of cross-sectional area 0.5 mm^2 and length 100 m is connected across a battery of e.m.f. 2 V and internal resistance 1Ω . The density, atomic mass and electrical conductivity of the metal are $6.35 \times 10^3 \text{ kg m}^{-3}$, 63.5 gm/mole and $2 \times 10^8 \text{ mho m}^{-1}$, respectively. Assuming one conduction electron per atom of the metal, the drift velocity (in mm s^{-1}) of the electrons in the wire is:
 [Take Avogadro's number as 6×10^{23} and charge of the electron as $1.6 \times 10^{-19} \text{ C}$.]
 (A) 0.052 (B) 0.104 (C) 0.208 (D) 0.156

Ans. [C]
Sol.

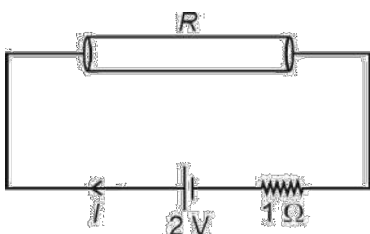

$$R = \frac{1}{2 \times 10^8} \times \frac{100}{0.5 \times 10^{-6}} = 1 \Omega$$

$$I = \frac{2}{1+1} = 1 \text{ A}$$

$$I = neAv_d$$

$$\text{moles/m}^3 = \frac{6.35 \times 10^3 \times 10^3}{63.5} = 10^5$$

$$\text{atoms/m}^3 = 10^5 \times 6 \times 10^{23}$$

$$= 6 \times 10^{28}$$

$$v_d = \frac{1}{6 \times 10^{28} \times 1.6 \times 10^{-19} \times 0.5 \times 10^{-6}}$$

$$= \frac{1}{4.8} \times 10^{-3}$$

$$= 0.208 \times 10^{-3} \text{ m/s}$$

$$v_d = 0.208 \text{ mm/s}$$

- Q.2** A nuclear reactor starts producing a radioactive nuclide X from $t = 0$, at a constant rate of α per second. Each decay of X produces energy E_0 , which is utilized to heat a liquid of mass m and specific heat s . Assuming no heat loss from the liquid and taking λ as the decay constant of X, the rate of increase in the temperature of the liquid is:

- (A) $\frac{\alpha E_0}{ms} (1 - e^{-\lambda t})$ (B) $\frac{\alpha E_0}{ms} (e^{\lambda t} - 1)$ (C) $\frac{\lambda E_0}{ms} (1 - e^{-\lambda t})$ (D) $\frac{E_0}{ms} (\alpha - \lambda e^{-\lambda t})$

Ans.
[A]
Sol.

$$\xrightarrow{\alpha} X \xrightarrow{\lambda}$$

$$t = 0 \quad 0$$

$$t = t \quad N$$

$$\frac{dN}{dt} = \alpha - \lambda N$$

$$\int \frac{dN}{\alpha - \lambda N} = \int dt$$

$$-\frac{1}{\lambda} \ln(\alpha - \lambda N) \Big|_0^N = t \Big|_0^t$$

$$\lambda N = \alpha(1 - e^{-\lambda t})$$

$$N = \frac{\alpha}{\lambda}(1 - e^{-\lambda t})$$

Number of decay per second.

$$\lambda N = \alpha(1 - e^{-\lambda t}) = \frac{\alpha E_0(1 - e^{-\lambda t})}{\text{ms}}$$

Q.3

A beam of polychromatic light passes through a thin prism of prism angle 6° . The refractive index of the material of the prism varies with wavelength (λ) as $n(\lambda) = \alpha\lambda + \frac{\beta}{\lambda^2}$, where $\alpha = 3\mu\text{m}^{-1}$ and $\beta = 0.096\mu\text{m}^2$. If λ_{\min} is the wavelength at which the angle of minimum deviation D_m is smallest, then the correct value of D_m at λ_{\min} is

 (A) 6.4°

 (B) 4.8°

 (C) 3.2°

 (D) 2.4°
Ans.
[B]
Sol.

$$D = (\mu - 1)A$$

$$D = \left(\alpha\lambda + \frac{\beta}{\lambda^2} - 1 \right) A$$

$$\frac{dD}{d\lambda} = \left(\alpha - \frac{2\beta}{\lambda^3} \right) A$$

$$\lambda_{\min}^3 = \frac{2\beta}{\alpha} = \frac{2 \times 0.096}{3}$$

$$\lambda_{\min}^3 = 0.064\mu\text{m}^3$$

$$\lambda_{\min} = 0.4\mu\text{m}$$

$$D_m = \left(3 \times 0.4 + \frac{0.096}{0.16} - 1 \right) 6^\circ$$

$$D_m = (1.2 + 0.6 - 1) 6^\circ = 0.8 \times 6^\circ = 4.8^\circ$$

Q.4

A particle of mass m , and angular momentum ℓ is moving in a circular orbit of radius r_0 under the influence of an attractive force $\vec{F}(r) = -\frac{k}{r^2} \hat{r}$. Keeping its angular momentum unchanged, the particle is displaced radially by a small distance $\delta r \ll r_0$, due to which its radial distance varies periodically. The corresponding time period is:

 (A) $\frac{2\pi\ell^3}{mk^2}$

 (B) $2\pi\sqrt{\frac{m}{k}}$

 (C) $\frac{2\pi\ell^3}{3mk^2}$

 (D) $\frac{2\pi\ell^3}{5mk^2}$



Ans. [A]

Sol. At eq. $\frac{k}{r_0^2} = \frac{mv_0^2}{r}$... (1)

$$F_{\text{net}} = \frac{k}{r^2} - \frac{mv^2}{r}$$

$$= \frac{k}{r^2} - \frac{\ell^2}{mr^3}$$

$$F'(r_0) = \frac{-2k}{r_0^3} + \frac{3\ell^2}{mr_0^4}$$

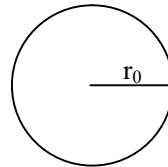

From Eqn. (1)

$$T = 2\pi \frac{mr_0^2}{\ell}$$

$$\frac{k}{r_0^2} = \frac{mv_0^2}{r}$$

$$T = \frac{2\pi\ell^3}{mk^2} \quad \dots(1)$$

$$\ell = mvr = mv_0r_0$$

SECTION – 2 (Maximum Mark : 16)

- This section contains **FIVE (05)** questions
- Each question has **FOUR** options (A), (B), (C) and (D). **ONE OR MORE THAN ONE** of these four option(s) is (are) correct answer(s).
- For each question, choose the option(s) corresponding to (all) the correct answer(s).
- Answer to each question will be evaluated according to the following marking scheme :

Full Marks	: +4	ONLY If (all) the correct option(s) is (are) chosen.
Partial Marks	: +3	If all the four options are correct but ONLY three options are chosen.
Partial Marks	: +2	If three or more options are correct but ONLY two options are chosen, both of which are correct.
Partial Marks	: +1	If two or more options are correct but ONLY one option is chosen and it is a correct option.
Zero Marks	: 0	If unanswered;
Negative Marks	: -1	In all other cases.
- For example, in a question, if (A), (B) and (D) are the **ONLY** three options corresponding to correct answers, than
 - choosing **ONLY** (A), (B) and (D) will get +4 marks;
 - choosing **ONLY** (A) and (B) will get +2 marks;
 - choosing **ONLY** (A) and (D) will get +2 marks;
 - choosing **ONLY** (B) and (D) will get +2 marks;
 - choosing **ONLY** (A) will get +1 mark;
 - choosing **ONLY** (B) will get +1 mark;
 - choosing **ONLY** (D) will get +1 mark;
 - choosing no option(s) (i.e. the question is unanswered) will get 0 marks and choosing any other option(s) will get -1 marks.

- Q.5** Consider two isosceles prisms 1 and 2 with prism angles A_1 and A_2 and refractive indices n_1 and n_2 , respectively, as shown in the figure. The faces a_1b_1 and a_2b_2 are parallel to each other and perpendicular to the mirror M . If a ray of light is incident on the face a_1c_1 and emerges from the face a_2c_2 , then the correct statement(s) is/are:

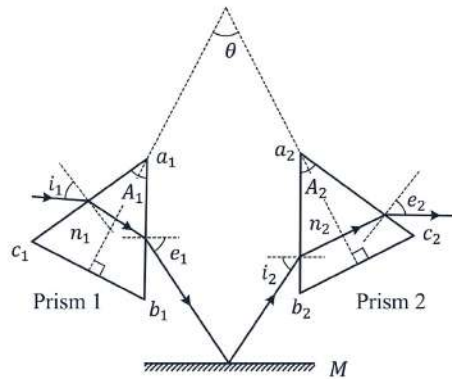

- (A) If both the prisms are at minimum deviation condition, then $\frac{n_2}{n_1} = \sin\left(\frac{A_1}{2}\right) / \sin\left(\frac{A_2}{2}\right)$.
- (B) If prism 2 is at minimum deviation condition, then $\sin i_1 = n_2 \sin\left(\frac{A_2}{2}\right)$ is always true.
- (C) If both the prisms 1 and 2 are thin and are at minimum deviation condition with angles of deviation δ_{m1} and δ_{m2} , respectively, then $\theta = \frac{\delta_{m1}}{2(n_1 - 1)} + \frac{\delta_{m2}}{2(n_2 - 1)}$.
- (D) If prism 1 is at minimum deviation condition, then $\sin i_2 = n_1 \sin\left(\frac{A_1}{2}\right)$ is always true.

Ans. [A,C,D]

Sol. (A) $\sin i_1 = \sin e_1 = n_1 \sin \frac{A_1}{2}$
 $\sin i_2 = \sin e_2 = n_2 \sin \frac{A_2}{2}$
 $e_1 = i_2 \Rightarrow n_1 \sin \frac{A_1}{2} = n_2 \sin \frac{A_2}{2}$

(B) $i_2 = e_2 = e_1$

$$\sin i_2 = n_2 \sin \frac{A_2}{2}$$

But $i_1 \neq i_2$

(C) $\delta_1 = (\mu_1 - 1)A_1, \delta_2 = (\mu_2 - 1)A_2$

$$\frac{1}{2} \left(\frac{\delta_1}{\mu_1 - 1} \right) + \frac{1}{2} \left(\frac{\delta_2}{\mu_2 - 1} \right) = \frac{1}{2} \frac{A_1}{2} + \frac{A_2}{2} = \theta$$

(D) $i_1 = e_1 = i_2$

$$\sin i_1 = n_1 \sin \frac{A_1}{2}$$



- Q.6** In a vacuum chamber, a particle of charge $1 \mu\text{C}$ and mass 1 mg is projected with a velocity $(\hat{i} + 2\hat{j}) \text{ m}^{-1}$ from the XZ plane at time $t = 0$ in an electric field of $1\hat{i} \text{ Vm}^{-1}$. At $t = 0.2 \text{ s}$, the electric field is switched off and a magnetic field of $6\hat{j} \text{ T}$ is switched on. The acceleration due to gravity is $-10\hat{j} \text{ ms}^{-2}$. Correct option(s) is/are:
- (A) The vertical distance of the particle from the XZ plane at $t = 0.3 \text{ s}$ is 15 cm .
 (B) The vertical distance of the particle from the XZ plane at $t = 0.4 \text{ s}$ is 10 cm .
 (C) The radius of the trajectory of the particle for $t > 0.2 \text{ s}$ is 20 cm .
 (D) The particle will be in the XZ plane at $t = 0.35 \text{ s}$.

Ans. [A,C]

Sol.

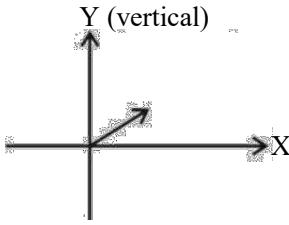

$$q = 10^{-6} \text{ C}, m = 10^{-6} \text{ kg}$$

$$\vec{u} = \hat{i} + 2\hat{j}$$

$$\vec{E} = 1\hat{i} \text{ V/m}$$

$$a_x = \frac{qE}{m} = 1 \text{ m/s}^2$$

$$a_y = -g = -10 \text{ m/s}^2$$

$$\text{at } t = 0.2 \text{ s}$$

$$v_x = 1 + 1 \times 0.2 = 1.2 \text{ m/s}$$

$$v_y = 2 - 10 \times (0.2) = 0 \text{ m/s}$$

$$y \text{ (at } t = 0.2 \text{ s)} = 2 \times 0.2 + \frac{1}{2} \times (-10) \times (0.2)^2$$

$$= 0.4 + \frac{1}{2} \times (-10) \times 0.04$$

$$= 0.40 - 0.20$$

$$= 0.20 \text{ m} = 20 \text{ cm}$$

$$\text{at } t = 0.3 \text{ s}, y = 0.20 - \frac{1}{2} \times 10 \times (0.1)^2$$

$$= 0.20 - 0.05$$

$$= 0.15 \text{ m} = 15 \text{ cm}$$

$$\text{at } t = 0.4 \text{ s}, y = 0.20 - \frac{1}{2} \times 10 \times (0.2)^2$$

$$= 0.20 - 0.20 = 0$$

$$\text{radius } r = \frac{mv}{qB} = \frac{10^{-6} \times 1.2}{10^{-6} \times 6} = 0.20$$



Q.7 Two charges $Q_1 = q$ and $Q_2 = mq$ are placed at the points $P_1(a, b)$ and $P_2(ma, mb)$, respectively, in the XY plane, where $a, b \neq 0$ and $m \neq 0, 1$. If V_1 is the potential at a point in the XY plane due to charge Q_1 and V_2 is the potential at that point due to charge Q_2 . Correct statement(s) for the points at which $|V_1| = |V_2|$ is/are:

(A) For $m = -1$, locus of these points is $ax + by = 0$.

(B) For $m = 2$, the locus of these points is a circle of radius $\frac{2}{3}\sqrt{a^2 + b^2}$ centered at $\left(\frac{2}{3}a, \frac{2}{3}b\right)$

(C) For $m = -2$, the locus of these points is a circle of radius $2\sqrt{a^2 + b^2}$ centered at $(2a, 2b)$

(D) For $m = -3$, locus of these points is $3bx + 3ay = 0$.

Ans. [A,B,C]

Sol.

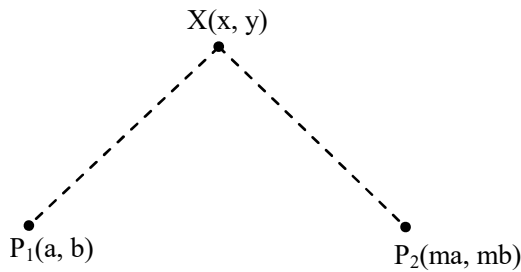

$$|V_1| = |V_2|$$

$$\Rightarrow \frac{|Kq|}{\sqrt{(x-a)^2 + (y-b)^2}} = \frac{|K(mq)|}{\sqrt{(x-ma)^2 + (y-mb)^2}}$$

$$\Rightarrow \frac{1}{(x-a)^2 + (y-b)^2} = \frac{m^2}{(x-ma)^2 + (y-mb)^2}$$

$$\Rightarrow (x-ma)^2 + (y-mb)^2 = m^2 [(x-a)^2 + (y-b)^2]$$

(A) For $m = -1, (x+a)^2 + (y+b)^2 = (x-a)^2 + (y-b)^2$

$$\Rightarrow ax + by = 0$$

(B) For $m = 2, (x-2a)^2 + (y-2b)^2 = 4[(x-a)^2 + (y-b)^2]$

$$\Rightarrow 3x^2 + 3y^2 - 4ax - 4by = 0$$

$$\Rightarrow x^2 + y^2 - \frac{4}{3}ax - \frac{4}{3}by = 0$$

$$\Rightarrow \left(x - \frac{2a}{3}\right)^2 + \left(y - \frac{2b}{3}\right)^2 = \frac{4(a^2 + b^2)}{9}$$

\therefore Locus is circle with centre at $\left(\frac{2a}{3}, \frac{2b}{3}\right)$ and radius $\frac{2}{3}\sqrt{a^2 + b^2}$

For $m = (-2)$

$$(x+2a)^2 + (y+2b)^2 = 4[(x-a)^2 + (y-b)^2]$$

$$\Rightarrow (x-2a)^2 + (y-2b)^2 = 4(a^2 + b^2)$$

$$\Rightarrow \text{Centre} \equiv (-2a, -2b), \text{ radius} = 2\sqrt{a^2 + b^2}$$

For $m = -3$

$$(x + 3a)^2 + (y + 3b)^2 = 9[(x - a)^2 + (y - b)^2]$$

$$\Rightarrow x^2 + y^2 + 3ax + 3by = 0$$

\therefore Locus is a circle

Q.8 Consider an electric dipole comprising two charges $+q$ and $-q$ each with mass m , separated by a fixed distance d and initially at rest with its dipole moment pointing along \hat{i} . A uniform electric field $E\hat{j}$ is turned on at time $t = 0$ and it is turned off at $t = t_f$, when the dipole moment makes an angle θ_f with \hat{i} . Neglecting any sources of energy loss, correct option(s) is/are:

(A) The center of mass of the dipole is deflected towards \hat{j} in the presence of the field.

(B) If the magnitude of the final angular velocity $\omega_f = \sqrt{\frac{2qE}{md}}$, then $\theta_f = \frac{\pi}{6}$.

(C) If $\theta_f = \pi/3$, then the change in kinetic energy of the dipole is given by $2\sqrt{3}qEd$.

(D) For $\theta_f = \pi/4$, the dipole rotates around its center of mass with a constant angular velocity after $t > t_f$.

Ans. [B,D]

Sol. $\vec{p} = qd\hat{i}$ at $t = 0, \vec{E} = E\hat{j}$

(A) $\because \vec{F}_+ + \vec{F}_- = 0 \Rightarrow$ COM remains at rest.

(B) $U_i = -\vec{p} \cdot \vec{E} = 0$ (at $t = 0$)

$$U_f = -\vec{p} \cdot \vec{E} = -pE\sin\theta$$

$$\Rightarrow \Delta U_{\text{loss}} = pE\sin\theta = \frac{1}{2}I\omega^2$$

$$\Rightarrow qdE \times \sin\theta = \frac{1}{2} \times \left(m \frac{d^2}{4} \times 2 \right) \times \omega^2$$

$$\Rightarrow qdE \times \sin\theta = \frac{1md^2}{4} \times \frac{2qE}{md} \text{ for (B)}$$

$$\Rightarrow \sin\theta = \frac{1}{2} \Rightarrow \theta = \frac{\pi}{6}$$

(C) For $\theta_f = \frac{\pi}{3}, \Delta U_{\text{loss}} = qdE \times \sin\left(\frac{\pi}{3}\right)$

$$= qdE \times \left(\frac{\sqrt{3}}{2}\right)$$

(D) For $\theta_f = \frac{\pi}{4}, \tau = 0$

\Rightarrow dipole rotates with constant angular speed.

- Q.9** Ten moles of an ideal monoatomic gas, initially in state **a** at atmospheric pressure and temperature $T_a = 27^\circ\text{C}$, is enclosed in a metal cylinder of volume V_0 fitted with a frictionless piston. The gas is suddenly compressed to state **b** with volume $V_0/3$. Now, keeping the piston stationary, the cylinder is submerged in a water bath of temperature 11°C until the gas reaches the temperature of the water bath, which is denoted as state **c**. Finally, while still in the water bath, the piston is brought slowly to its initial position, which is denoted as state **f**. If R is universal gas constant, then the correct option(s) is/are: [Given: $9^{1/3} = 2.08$]

(A) The schematic P-V diagram of the processes described above is :

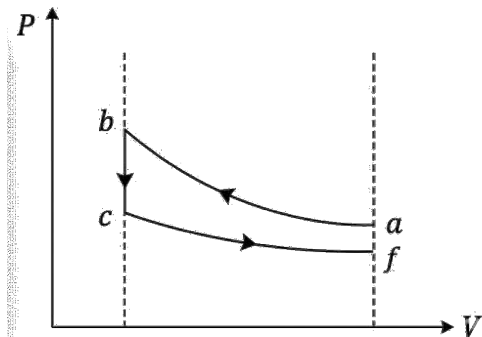

- (B) The change in internal energy in going from state **a** to **b** is $4860 R$.
 (C) The net change in the internal energy in the whole process is $-240 R$.
 (D) The pressure and temperature of the state **b** are 2.08 times the atmospheric pressure and 624 K , respectively.

Ans. [A,B,C]

Sol. $n = 10, \gamma = \frac{5}{3}, T_a = 300 \text{ K}$,

$$T_1 V_1^{\gamma-1} = T_2 V_2^{\gamma-1}$$

$$\Rightarrow T_2 = T_1 \left(\frac{V_1}{V_2} \right)^{\gamma-1} = 300 \times (3)^{2/3} = 300 \times 2.08$$

$$\Rightarrow T_b = 624 \text{ K}$$

$$\Delta U = nC_v \Delta T$$

$$= 10 \times \frac{R}{\gamma-1} \times (624 - 300)$$

$$= 4860 R$$

$$T_c = 273 + 11 = 284 \text{ K}$$

$$\therefore \Delta U_f = nC_v (284 - 300)$$

$$= 10 \times \frac{3R}{2} \times (-16)$$

$$= -240R$$

$$P_1 V_1^\gamma = P_2 V_2^\gamma$$

$$\Rightarrow P_2 = P_0 \times (3)^{5/3} \neq 2.08 P_0$$

And, given graph in option (A) represents the process.

Correct options (A, B, C)

SECTION – 3 (Maximum Marks: 32)

- This section contains **FIVE (05)** questions.
- The answer to each question is a **NUMERICAL VALUE**.
- For each question, enter the correct integer corresponding to the answer using the mouse and the on-screen virtual numeric keypad in the place designated to enter the answer.
- If the numerical value has more than two decimal places, truncate/round-off the value to **TWO** decimal places.
- Answer to each question will be evaluated according to the following marking scheme :
Full Marks : +4 If **ONLY** the correct integer is entered;
Zero Marks : 0 In all other cases.

- Q.10** Two thin wires, Wire-1 of diameter 0.650 mm and Wire-2 of unknown diameter d are given. To obtain the value of d , the diameters of the two wires are measured with a screw gauge. The screw gauge has a pitch of 0.5 mm and there are 100 divisions on the circular scale (CS). The smallest division on the linear scale (LS) is 0.5 mm. The table shows the readings of LS and CS for the measurements. The value of d (in μm) is:

	Readings	
	LS (mm)	CS
Wire-1	0.5	42
Wire-2	1.5	95

Ans. [1915.00]

Sol. Pitch = 0.5 mm

$$\text{Least count} = \frac{0.5}{100} = 0.005$$

Wire-1

$$0.650 = 0.5 + 42 \times 0.005 - \text{zero error}$$

$$\text{Zero error} = 0.06$$

Wire-2

$$d = 1.5 + 95 \times 0.005 - 0.06$$

$$d = 1.915 \text{ mm}$$

- Q.11** In a single slit diffraction experiment, a slit of width (0.016 ± 0.002) mm is used to measure the wavelength of a monochromatic light source. In the diffraction pattern, the angular distance between the central maximum and first minimum is measured to be $(2^\circ \pm 40')$. The value of the fractional error in the measurement of wavelength is: [Given: $\sin(2^\circ) = 0.035$]

Ans. [0.46]

Sol. $\theta = \frac{\lambda}{a}$

$$\frac{\Delta\lambda}{\lambda} = \frac{\Delta\theta}{\theta} + \frac{\Delta a}{a}$$

$$= \left(\frac{40}{60} + \frac{0.002}{0.016} \right)$$

$$= \frac{1}{3} + \frac{1}{8} = \frac{11}{24}$$

$$\frac{\Delta\lambda}{\lambda} \approx 0.46$$

Q.12 As shown in the figure, a ray AB of unpolarized light enters from water of refractive index $n_w = 4/3$ into a medium of refractive index $n_p = 4/\sqrt{3}$ after passing through a glass plate of refractive index $n_g = 1.5$ and a layer of water. At a particular incident angle i the reflected ray CD is polarized in the direction as shown in the figure. The value of i (in degrees) is:

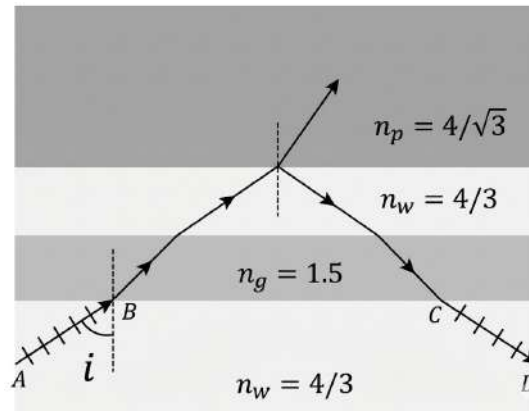

Ans. [60.00]

Sol. $\frac{4}{\sqrt{3}} \sin(q_0 - i_1) = \frac{4}{3} \sin i_1$

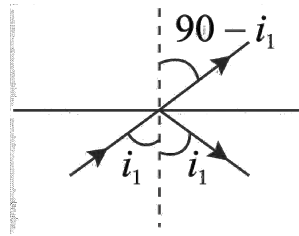

$$\begin{aligned} \tan i_1 &= \sqrt{3} \\ i_1 &= 60^\circ \\ \frac{4}{3} \sin i &= \frac{4}{3} \sin i_1 \\ i &= 60^\circ \end{aligned}$$

Q.13 As shown in the figure, the resistance of a galvanometer G can be found by the half-deflection method. Here the resistance R_2 is adjusted such that when the key K is closed the deflection in the galvanometer becomes half of the value as compared to when K is open. Half-deflection is obtained at $R_2 = 4 \Omega$ and thus the galvanometer resistance is found to be 6Ω . In this half-deflection condition the current (in mA) through the resistor R_1 is:

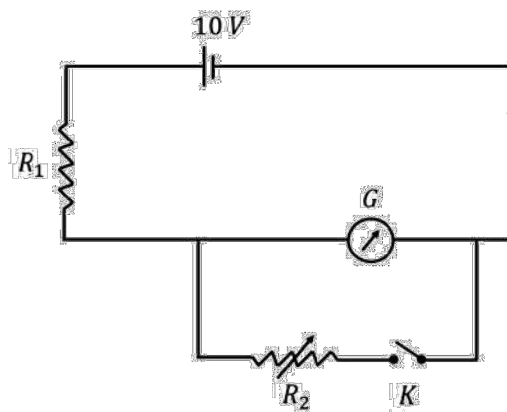

Ans. [694.44]

Sol.

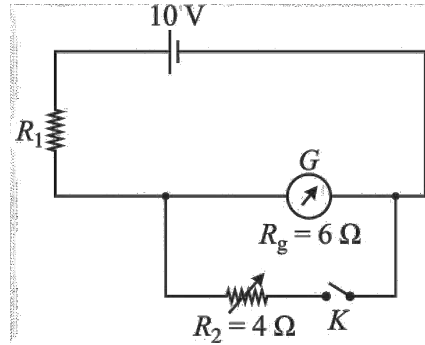

In half-deflection method.

$$R_g = \frac{R_1 R_2}{R_1 - R_2}$$

$$6 = \frac{R_1 \times 4}{R_1 - 4}$$

$$R_1 = 12 \Omega$$

$$R_g = 12 + \frac{4 \times 6}{10} = 14.4$$

$$I = \frac{10}{14.4} = 0.6944 \text{ A}$$

Q.14 In a new system of units, the units of mass, length, time and current are 5 kg, 5 m, 5 s and 5 A, respectively. If μ_0 and ϵ_0 are the permeability and permittivity of free space, respectively, then in this new system of units, the magnitude of one SI unit of $\sqrt{\mu_0 / \epsilon_0}$, is:

Ans. [25.00]

Sol. $M_2 = 5 \text{ kg}$

$$L_2 = 5 \text{ m}$$

$$T = 5 \text{ sec}$$

$$I_2 = 5 \text{ A}$$

$$[\mu_0] = [MLT^{-2}I^{-2}]$$

$$[\epsilon_0] = [M^{-1}L^{-3}T^4I^2]$$

$$\left[\sqrt{\frac{\mu_0}{\epsilon_0}} \right] = ML^2T^{-3}I^{-2}$$

$$n_2 = n_1 \left(\frac{M_1}{M_2} \right)^1 \left(\frac{L_1}{L_2} \right)^2 \left(\frac{T_1}{T_2} \right)^{-3} \left(\frac{I_1}{I_2} \right)^{-2}$$

$$n_2 = 1 \left(\frac{1}{5} \right) \left(\frac{1}{5} \right)^2 \left(\frac{1}{5} \right)^{-3} \left(\frac{1}{5} \right)^{-2}$$

$$n_2 = 25 \text{ units}$$

SECTION – 4 (Maximum Marks: 8)

- This section contains **TWO (02)** questions.
- There are **TWO (02)** questions corresponding to each question stem.
- The answer to each question is a **NUMERICAL VALUE**.
- For each question, enter the correct numerical value corresponding to the answer in the designated place using the mouse and the on-screen virtual numeric keypad.
- If the numerical value has more than two decimal places, truncate/round-off the value to **TWO** decimal places.
- Answer to each question will be evaluated according to the following marking scheme :

Full Marks	: +2	If ONLY the correct numerical value is entered at the designated place;
Zero Marks	: 0	In all other cases.

Question Stem for Question Nos. 15 and 16

A container of height 2 m, length 2 m and breadth 1 m is made of insulating vertical walls and two large area horizontal metal plates (M_1 and M_2) which extend far beyond the vertical walls in all directions. The container is partitioned into two equal chambers with a thin insulating vertical wall.

The partition wall contains a small hole of cross-sectional area $\sqrt{10}$ cm² near its bottom edge. Initially the hole is closed and the left chamber of the container is completely filled with a liquid of dielectric constant $\epsilon_r = 15$ and the right chamber is empty ($\epsilon_r = 1$). At time $t = 0$, the hole is opened and the liquid flows from the left chamber to the right chamber. In both the chambers, the space above the liquid has $\epsilon_r = 1$ and is maintained at atmospheric pressure. The schematic of the container at a time $t > 0$ is shown in the figure. [Given: acceleration due to gravity is 10 ms⁻²]

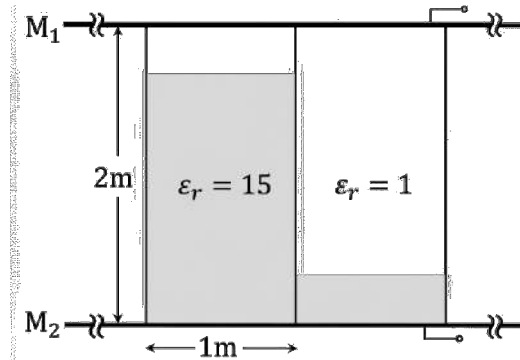

Q.15 The height (in m) of the liquid in left chamber at $t = 500$ s is:

Ans. [1.25]

Sol.

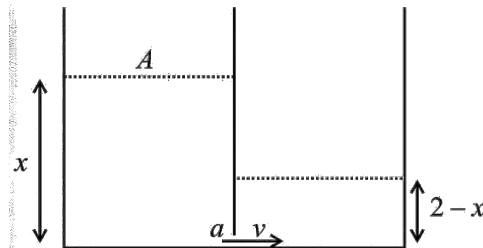

$$(P_0 + \rho gx) - (P_0 + \rho g(2 - x)) = \frac{1}{2} \rho v^2$$

$$\sqrt{2(2x - 2)g} = v$$

$$\sqrt{4(x - 1)g} = v$$

$$A \left(-\frac{dx}{dt} \right) = a \sqrt{4g(x-1)}$$

$$\int_2^{x_0} -\frac{dx}{\sqrt{x-1}} = \int_0^t \frac{a}{A} \sqrt{4g} \cdot dt$$

$$2(1 - \sqrt{x_0 - 1}) = \frac{\sqrt{10} \times 10^{-4}}{1} \cdot 2\sqrt{10} \times 500$$

$$2(1 - \sqrt{x_0 - 1}) = 1$$

$$\sqrt{x_0 - 1} = \frac{1}{2}$$

$$x_0 = 1.25$$

Q.16 The difference in the capacitance (in F) between the metal plates at $t = 0$ and that at $t = 500$ s is $(8 - n)\epsilon_0$, where ϵ_0 is the permittivity of free space. The value of n is:

Ans. [1.97]

Sol. $C_0 \left(\frac{1 \times 1 \times \epsilon_0}{2} \right) 15 + \frac{\epsilon_0}{1} = 8\epsilon_0$

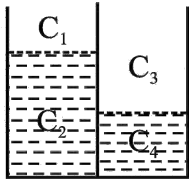

$$C_1 = \frac{4}{3} \epsilon_0$$

$$C_2 = 12 \epsilon_0$$

$$\frac{C_1 C_2}{C_1 + C_2} = \frac{6 \epsilon_0}{5}$$

$$C_3 = \frac{4 \epsilon_0}{3}$$

$$C_4 = 20 \epsilon_0$$

$$\frac{C_3 C_4}{C_3 + C_4} = \frac{10}{13} \epsilon_0$$

$$C_{\text{new}} = \left(\frac{6}{5} + \frac{10}{13} \right) \epsilon_0 = \frac{128}{65} \epsilon_0$$

$$\text{The difference in the capacitance} = \left(8 - \frac{128}{65} \right) \epsilon_0$$

$$n = 1.97$$

Question Stem for Question Nos. 17 and 18

A uniform circular disk of radius 0.2 m and mass 1 kg is pivoted at its top point C such that it can rotate freely around C in the XY plane, as shown in the figure. Initially, when the disk is at rest, a particle of mass 20 g, travelling along negative x-direction in the XY plane with speed 100 ms^{-1} , hits the circumference of the disk at a point P. After collision the particle moves along negative y-direction at a speed of 90 ms^{-1} .

[Given: the acceleration due to gravity (g) = $-10 \hat{j} \text{ ms}^{-2}$]

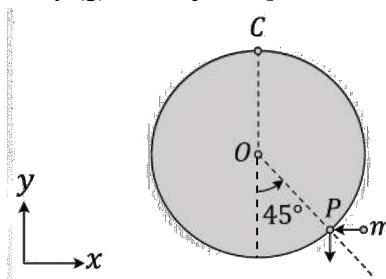

Q.17 After the collision the disk starts to rotate around point C in the XY plane. The maximum change in the height (in m) of its center O is:

Ans. [0.15]

Sol.

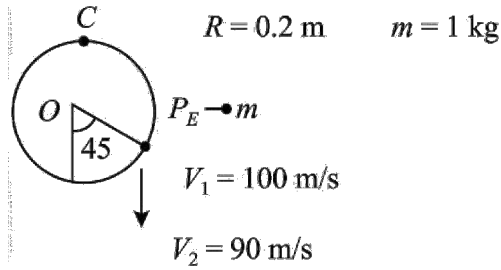

Conserving the angular momentum about C

$$m \left[R + \frac{R}{\sqrt{2}} \right] (-k) = m 90 \frac{R}{\sqrt{2}} (-k) + \frac{3}{2} m R^2 \omega (-k)$$

Putting the values of $m = \frac{20}{1000} \text{ Kg}$

$$m = 1 \text{ kg}$$

we get

$$R = 0.2 \text{ m}$$

$$\omega = \frac{21.414}{3} = 7.138 \text{ rad/s}$$

Now for disc conserving the mechanical energy

$$\frac{1}{2} I \omega^2 = mgh$$

$$\frac{1}{2} \frac{3}{4} m R^2 \omega^2 = mgh$$

$$h = \frac{3 R^2 \omega^2}{4 g}$$

Putting values of R, ω and g

$$h = 0.15 \text{ m}$$

Q.18 Amount of energy loss (in J) in the collision is:

Ans. [17.47]

Sol. Loss is energy in collision = $K_i - K_f$

$$= \frac{1}{2} m v_1^2 - \left(\frac{1}{2} m v_2^2 + \frac{1}{2} I \omega^2 \right)$$

Putting $v_1 = 100 \text{ m/s}$ $v_2 = 90 \text{ m/s}$

$$\omega = 7.138 \text{ rad/s}$$

We get

$$\text{Loss in energy} = 17.47 \text{ J}$$

CHEMISTRY

SECTION – 1 (Maximum Mark : 12)

- This section contains **FOUR (04)** questions.
- Each question has **FOUR** options (A), (B), (C) and (D). **ONLY ONE** of these four option is the correct answer.
- For each question, choose the option corresponding to the correct answer.
- Answer to each question will be evaluated **according to the following marking scheme** :
 - Full Marks : +3 If **ONLY** the correct option is chosen;
 - Zero Marks : 0 If none of the option is chosen (i.e. the question is unanswered);
 - Negative Marks : -1 In all other cases.

Q. 1 At 300 K, the molar conductivities of the aqueous solutions of three salts at two different concentrations are given below:

Salt	Concentration (M)	Molar conductivity ($\text{Scm}^2 \text{mol}^{-1}$)
NaNO ₃	0.01	111
	0.04	101
NaCl	0.01	117
	0.04	107
AgNO ₃	0.01	125
	0.04	116

The conductivity of a saturated aqueous solution of AgCl is $1.40 \times 10^{-6} \text{ S cm}^{-1}$ at 300 K. If the solubility of AgCl in water at 300 K is $X \text{ mol L}^{-1}$, then $\log_{10}(X^{-1})$ is

(Assume that AgCl dissolved in water ionizes completely and that the molar conductivity of saturated AgCl solution is equal to its limiting molar conductivity.)

- (A) 3 (B) 4 (C) 5 (D) 6

Ans. [C]

Sol. $\Lambda_M = \Lambda_M^\circ - b\sqrt{c}$

$$\Lambda_{M,1} - \Lambda_{M,2} = b[\sqrt{c_2} - \sqrt{c_1}]$$

$$b = \frac{\Lambda_{M,1} - \Lambda_{M,2}}{\sqrt{0.04} - \sqrt{0.01}} = \frac{\Lambda_{M,1} - \Lambda_{M,2}}{0.1}$$

For NaNO₃,

$$b = \frac{111 - 101}{0.1} = 100$$

$$[\Lambda_M^\circ]_{\text{NaNO}_3} = \Lambda_M + b\sqrt{c} = 111 + 100(0.1) = 121 \text{ S cm}^2 / \text{mol}$$

For NaCl,

$$b = \frac{117 - 107}{0.1} = \frac{10}{0.1} = 100$$

$$[\Lambda_M^\circ]_{\text{NaCl}} = 117 + 100 \times 0.1 = 127 \text{ S cm}^2 / \text{mol}$$

For AgNO₃,

$$b = \frac{125 - 116}{0.1} = 90$$

$$[\Lambda_M^\circ]_{\text{AgNO}_3} = 125 + 90(0.1) = 134 \text{ S cm}^2 / \text{mol}$$

$$\begin{aligned} \text{Now, } [\Lambda_M^{\circ}]_{\text{AgCl}} &= [\Lambda_M^{\circ}]_{\text{AgNO}_3} + [\Lambda_M^{\circ}]_{\text{NaCl}} - [\Lambda_M^{\circ}]_{\text{NaNO}_3} \\ &= 134 + 127 - 121 \\ &= 140 \text{ S cm}^2/\text{mol} \end{aligned}$$

$$\text{Now, } \Lambda_M = \Lambda_M^{\circ} = \frac{k \times 1000}{5} = \frac{1.4 \times 10^{-6} \times 10^3}{5}$$

$$S = \frac{1.4 \times 10^{-3}}{140} = 10^{-5} \text{ M} = X$$

$$\log(X^{-1}) = \log(10^{-5})^{-1} = 5$$

Q.2 The correct order of ONO bond angle in the given species is

- (A) $\text{NO}_2^+ < \text{NO}_2 < \text{NO}_3^- < \text{NO}_2^-$ (B) $\text{NO}_2^- < \text{NO}_3^- < \text{NO}_2 < \text{NO}_2^+$
 (C) $\text{NO}_3^- < \text{NO}_2^- < \text{NO}_2 < \text{NO}_2^+$ (D) $\text{NO}_2^- < \text{NO}_3^- < \text{NO}_2^+ < \text{NO}_2$

Ans. [B]

Sol. NO_2^+ NO_2 NO_3^- NO_2^-
 sp sp^2 sp^2 sp^2

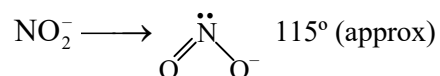
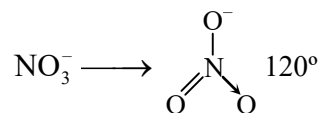
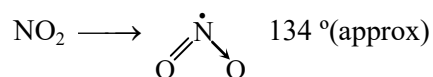
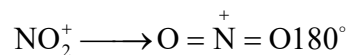

$\text{NO}_2^- < \text{NO}_3^- < \text{NO}_2 < \text{NO}_2^+$ bond angle order.

Q.3 Natural rubber on complete ozonolysis ($\text{O}_3/\text{Zn-H}_2\text{O}$) gives compound **X** as the major product. **X** gives positive iodoform and Tollen's tests. **X** on heating with aqueous NaOH gives **Y** as the major product. **Y** is

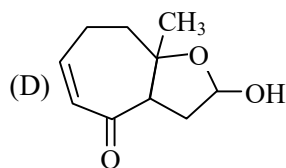
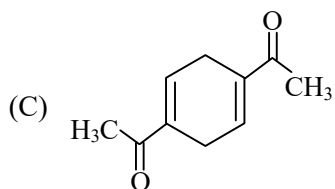
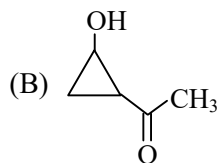
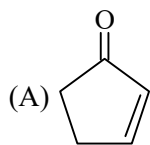

Ans. [A]

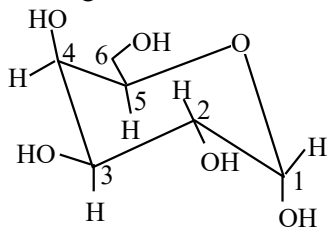
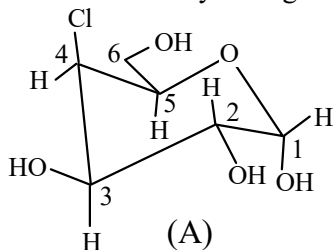
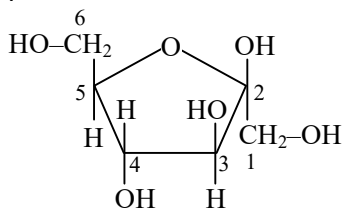
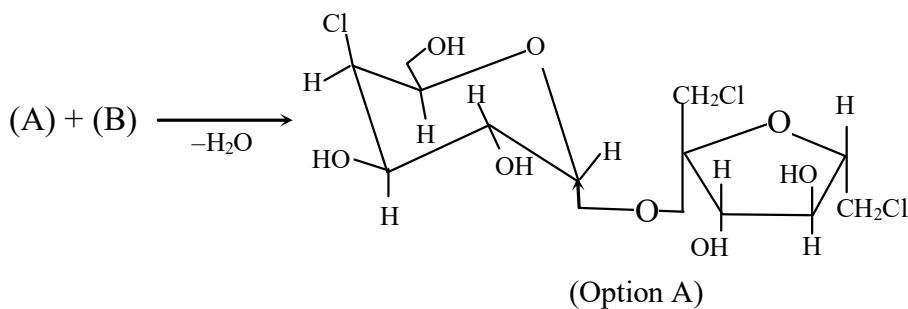
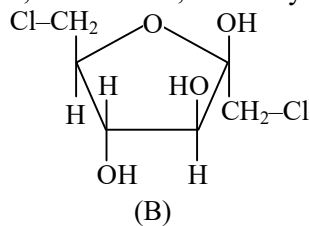
Sol.
 α -D-galactose

 4-chloro-4-deoxy- α -D-galactose :

 β -D-fructose :

 1,6-dichloro-1,6-dideoxy- β -D-fructose :

SECTION – 2 (Maximum Mark : 20)

- This section contains **Five (05)** questions
- Each question has **FOUR** options (A), (B), (C) and (D). **ONE OR MORE THAN ONE** of these four option(s) is (are) correct answer(s).
- For each question, choose the option(s) corresponding to (all) the correct answer(s).
- Answer to each question will be evaluated **according to the following marking scheme** :

Full Marks	: +4	ONLY If (all) the correct option(s) is (are) chosen.
Partial Marks	: +3	If all the four options are correct but ONLY three options are chosen.

- Partial Marks : +2 If three or more options are correct but **ONLY** two options are chosen, both of which are correct.
- Partial Marks : +1 If two or more options are correct but **ONLY** one option is chosen and it is a correct option.
- Zero Marks : 0 If none of the options is chosen (i.e. the question is unanswered);
- Negative Marks : -1 In all other cases.

- For example, in a question, if (A), (B) and (D) are the **ONLY** three options corresponding to correct answers, then
 - choosing **ONLY** (A), (B) and (D) will get +4 marks;
 - choosing **ONLY** (A) and (B) will get +2 marks;
 - choosing **ONLY** (A) and (D) will get +2 marks;
 - choosing **ONLY** (B) and (D) will get +2 marks;
 - choosing **ONLY** (A) will get +1 mark;
 - choosing **ONLY** (B) will get +1 mark;
 - choosing **ONLY** (D) will get +1 mark;
 - choosing no option(s) (i.e. the question is unanswered) will get 0 marks and
 - choosing any other combination of options will get -2 marks.

Q.5 For a first-order reaction $R \rightarrow P$ at a given temperature, k is the rate constant. For this reaction, at the given temperature, the concentrations of R and P at a time t are $[R]$ and $[P]$, respectively. The correct graphical representation(s) for this reaction is(are)

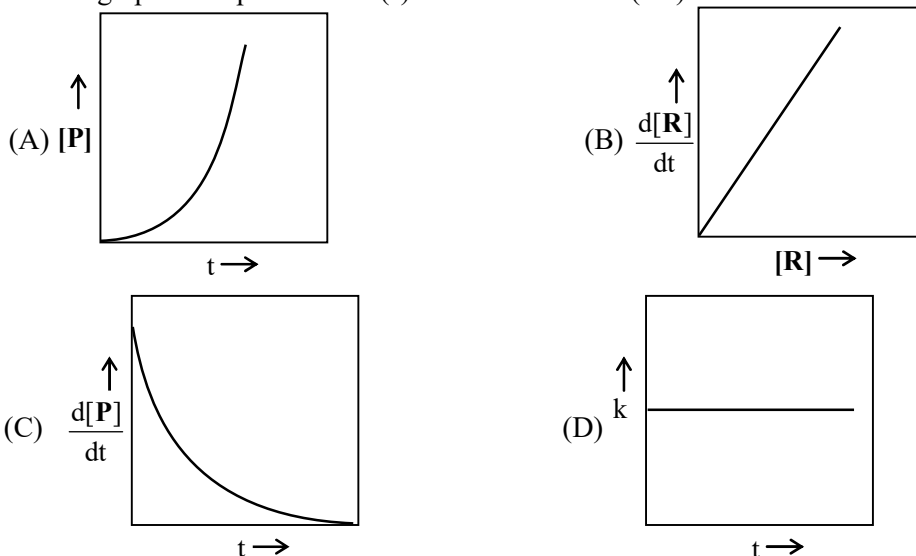

Ans. [C,D]

Sol. (A) is incorrect, because the correct graph is

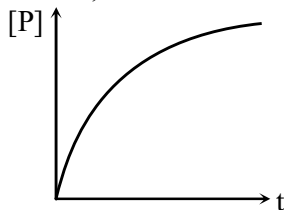

(B) is incorrect, because $-\frac{d[R]}{dt} = k \cdot [R]^1$

(C) is correct, because $\frac{d[P]}{dt} = k \cdot [R]^1$

(D) is correct, because k only depends on temperature.

Q.6 Correct statement(s) about the compounds **P**, **Q** and **R** is(are)

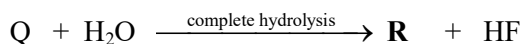
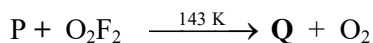
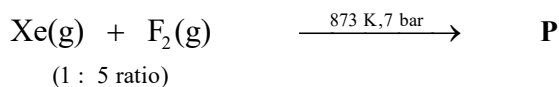

- (A) **P** has two lone pairs of electrons on the central atom.
 (B) **Q** has a perfect octahedral geometry.
 (C) **Q** can act as a fluorinating agent.
 (D) The molecular structure of **R** is trigonal pyramidal.

Ans. [A,C,D]

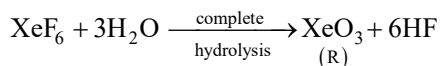
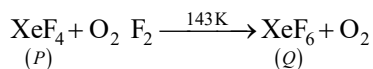
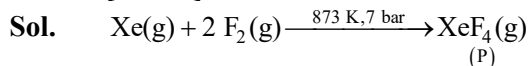

- (A) XeF_4 has 2 lone pair on Xe atom.
 (B) Q is XeF_6 , which is distorted octahedral.
 (C) (Q) XeF_6 can acts as fluorinating agent for e.g: $2\text{XeF}_6 + \text{SiO}_2 \rightarrow 2\text{XeOF}_4 + \text{SiF}_4$.

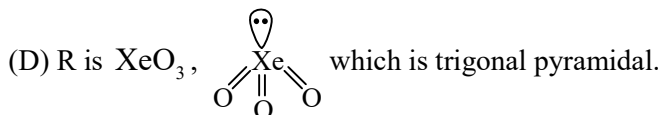

Q.7 The correct statement(s) regarding the periodic properties of elements is(are)

- (A) Second ionization enthalpy of carbon atom is less than that of boron atom.
 (B) Increasing order of ionic radii: $\text{Al}^{3+} < \text{Mg}^{2+} < \text{Na}^+$
 (C) Under identical conditions, in solid state, the density of potassium metal is more than density of sodium metal.
 (D) The H – H bond is weaker than F – F bond.

Ans. [A,B]

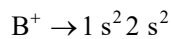
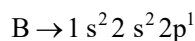
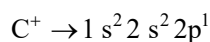
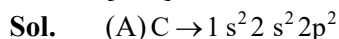

IE_2 of B > IE_2 of C (correct)

(B) Al^{3+} , Mg^{2+} and Na^+ are isoelectronic species

For isoelectronic species

$$\text{Ionic size} \propto \frac{1}{\text{number of proton}}$$

Number of proton

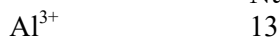

Ionic size order $\text{Al}^{3+} < \text{Mg}^{2+} < \text{Na}^+$ (correct)

(C) Density of K = 0.86 g / cm³

Density of Na = 0.97 g / cm³

Density of Na > K (incorrect)

(D) H – H BE = 435.88 kJ/mol

F – F BE = 155 kJ/mol

F – F bond is weaker than H – H bond (incorrect)

Q.8 In the following reaction sequence, **P**, **Q**, **S** and **T** are the major products.

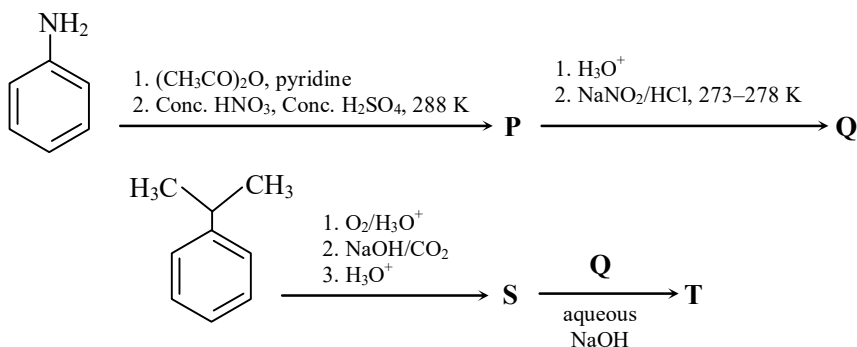

The correct statement(s) about **P**, **Q**, **S** and **T** is(are)

- (A) Q on treatment with ethanol generates an aromatic aldehyde.
- (B) S gives positive phthalein dye test.
- (C) **P** is a dinitro compound.
- (D) T is a coloured compound.

Ans. [B,D]

Sol.

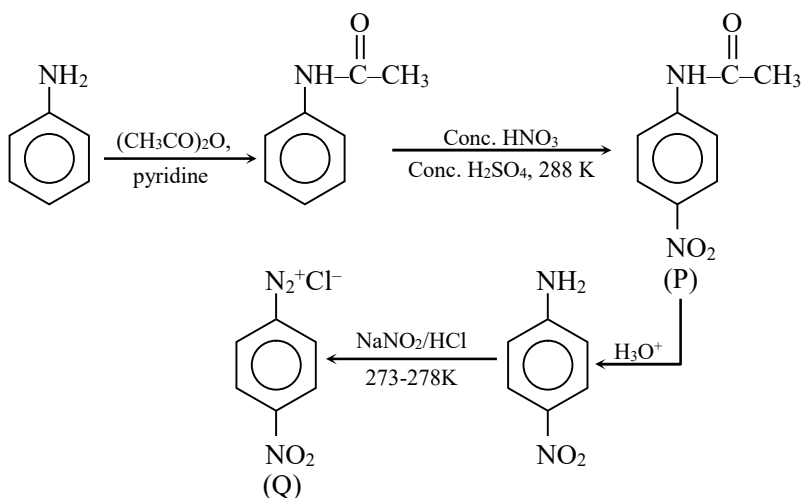

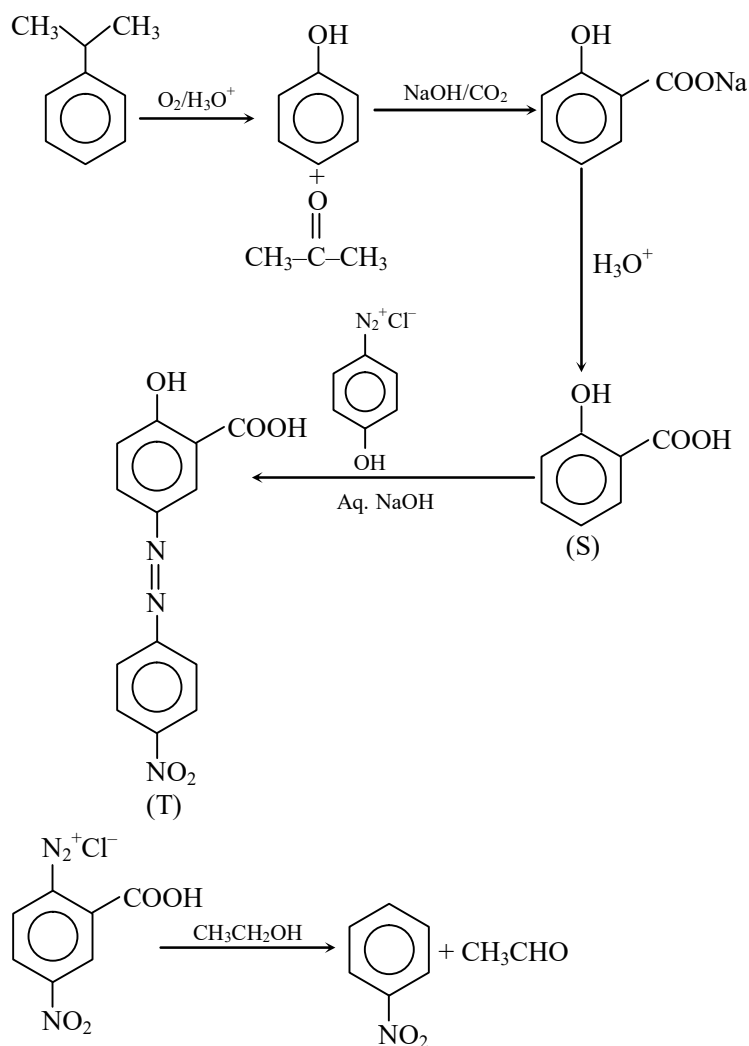

- CH_3CHO is an aliphatic aldehyde.
- S contains phenolic OH group hence it gives phthalein dye test.
- P contains only single NO_2 group.
- T is an azo compound hence coloured.

Q.9 The correct statement(s) regarding sugars is(are)

Given: Specific rotations of L-(–)-glucose and L-(+)-fructose are -52.5° and $+92.5^\circ$, respectively.

- (A) On treatment with HNO_3 , gluconic acid is oxidized to saccharic acid, whereas glucose is not oxidized to saccharic acid.
- (B) Fructose gives a positive Fehling's test because it isomerises to glucose and another aldohexose in the presence of Fehling's reagent.
- (C) Invert sugar is an equimolar mixture of D-glucose and D-fructose formed after hydrolysis of the corresponding disaccharide.
- (D) Specific rotation of invert sugar is -40° .

Ans. [B,C]

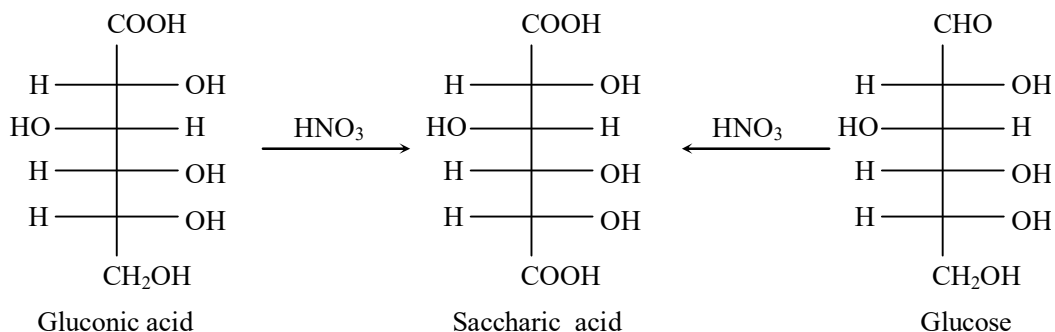
Sol.

(A) is incorrect.

(B) is correct as fructose isomerises to glucose and another aldohexoses in the presence of Fehling's reagent.

(C) Invert sugar is equimolar mixture of D-glucose and D-fructose.

(D) Specific rotation of D-fructose $\Rightarrow -92.5^\circ$

Specific rotation of D-glucose $\Rightarrow +52.5^\circ$

$$\text{Specific rotation of invert sugar} = -\frac{40}{2} = -20^\circ$$

(D) is incorrect.

SECTION – 3 (Maximum Marks: 20)

- This section contains **Five (05)** questions.
- The answer to each question is a **NUMERICAL VALUE**.
- For each question, enter the correct numerical value corresponding to the answer in the designated place using the mouse and the on-screen virtual numeric keypad.
- If the numerical value has more than two decimal places, **truncate/round-off** the value to **TWO** decimal places.
- Answer to each question will be evaluated **according to the following marking scheme** :

Full Marks	: +4	If ONLY the correct numerical value is entered in the designated place;
Zero Marks	: 0	In all other cases.

Q.10 X^{a+} and Y^{b+} are hydrogen-like species. The wavelength of light absorbed during the transition between the states with principal quantum numbers $n = 1$ and $n = 2$ of X^{a+} is λ . The wavelength of light absorbed during the transition between the states with principal quantum numbers $n = 2$ and $n = 4$ of Y^{b+} is 9λ . The lowest possible value of **(a + b)** is _____ .

Ans. [03.00]

Sol. X^{a+} Y^{b+}

$$\text{For } X^{a+} \text{ ion} \Rightarrow \frac{1}{\lambda} = R(z_{X^{a+}})^2 \left[\frac{1}{1^2} - \frac{1}{2^2} \right]$$

$$\frac{1}{\lambda} = R(z_1)^2 \times \frac{3}{4} \dots \text{(i)}$$

$$\text{For } Y^{b+} \text{ ion} \Rightarrow \frac{1}{9\lambda} = R(Z_{Y^{b+}})^2 \times \left[\frac{1}{2^2} - \frac{1}{4^2} \right]$$

$$\frac{1}{9\lambda} = R(z_2)^2 \times \left[\frac{3}{16} \right] \dots \text{(ii)}$$

$$\frac{\text{(i)}}{\text{(ii)}} \Rightarrow \frac{\frac{1}{\lambda}}{\frac{1}{9\lambda}} = \frac{R(z_1)^2 \times \frac{3}{4}}{R(z_2)^2 \times \frac{3}{16}}$$

$$\Rightarrow 9 = \frac{z_1^2}{z_2^2} \times 4$$

$$\frac{9}{4} = \frac{z_1^2}{z_2^2}$$

$$\frac{3}{2} \Leftarrow \frac{z_1}{z_2}$$

\therefore For lowest possible value of a and bX^{a+} will be Li^{2+} and Y^{b+} will be He^+ .

$$a = 2, b = 1$$

$$a + b = 3$$

- Q. 11** At a given temperature, 0.45 g of acetic acid in 50 mL of water is shaken with 1.0 g of charcoal and the pH of the resulting solution is 3.0. Assume, the adsorption of acetic acid from the aqueous solution by charcoal follows Freundlich isotherm,

$$\frac{x}{m} = kC^{1/n}$$

If the plot of $\log_{10}(x/m)$ against $\log_{10}C$ gives a straight line with slope 1, the value of k in $Lmol^{-1}$ is _____.

Given: The molar mass of acetic acid is 60 g mol^{-1} .

The acid dissociation constant of acetic acid is 1.0×10^{-5} at the given temperature.

x is the mass (in grams) of acetic acid adsorbed.

m is the mass (in grams) of charcoal.

C is the equilibrium concentration of acetic acid in the solution after the adsorption is complete.

k and n are constants for acetic acid-charcoal system at the given temperature.

Ans. [01.50]

Sol. $K_a = 1 \times 10^{-5}$

After shaking $pH = 3$

$$[H^+] = 10^{-3} = \sqrt{K_a \times C}$$

$$10^{-3} = \sqrt{10^{-5} \times C}$$

$$C = 0.1M$$

Let mass left after shaking w_g

$$10^{-1} = \frac{w}{50} \times 1000$$

$$w = 0.3 \text{ g}$$

$$\begin{aligned} \text{mass adsorbed} &= 0.45 - 0.3 \\ &= 0.15 \text{ g} \end{aligned}$$

$$\frac{x}{m} = kC^{1/n}$$

$$\log \frac{x}{m} = \log k + \frac{1}{n} \log C$$

$$\text{Slope} = 1 = \frac{1}{n} \Rightarrow n = 1$$

$$\frac{x}{m} = kC^1$$

$$\frac{0.15}{1} = k \times 0.1$$

$$1.5 = k$$

Q.12 In a solvent **S**, a compound **B** is partially dissociated into **C** and **D** as given below:



B, **C** and **D** are non-volatile in nature. The molar mass of **B** is 10 times the molar mass of **S**. The standard boiling point and the standard enthalpy of vaporization of **S** are 400 K and $10R \text{ J mol}^{-1}$, respectively (R is the gas constant in $\text{JK}^{-1}\text{mol}^{-1}$). A solution of **B** in **S** with an initial concentration of **B** as 0.25% (mass/mass) has a boiling point of 408 K at 1 bar pressure. In this solution, the mole percent of **B** that has been dissociated is

Ans. [33.17]

Sol. $\mathbf{B} \rightleftharpoons 2\mathbf{C} + 2\mathbf{D}$

Let molar mass of **S** = x , molar mass of **B** = $10x$.

$$\Delta T_b = \left(\frac{R \times M \times T_b^{\circ 2}}{1000 \times \Delta H_{\text{vap}}} \right) \times m \times i$$

$$(408 - 400) = \left\{ \frac{R \times x \times (400)^2}{1000 \times 10R} \right\} \times \left(\frac{0.25 \times 1000}{10x \times 99.75} \right) \times i$$

On solving, $i = 1.995$

$$i = (1 - \alpha) + \alpha(2 + 2)$$

$$1.995 = 1 + 3\alpha$$

$$\alpha = 0.3316$$

$$\text{Dissociated mol \% of B} = 0.3316 \times 100 = 33.16\%$$

Q.13 Consider that the coordinating atoms of the ligands in *cis*- $[\text{Co}(\text{NH}_3)_4\text{Cl}_2]\text{Cl}$ and *mer*- $[\text{Co}(\text{NH}_3)_3\text{Cl}_3]$ octahedral complexes are at the vertices of an octahedron. The sum of total number of the triangular faces in both the complexes having one N atom and two Cl atoms at their corners is

Ans. [06.00]

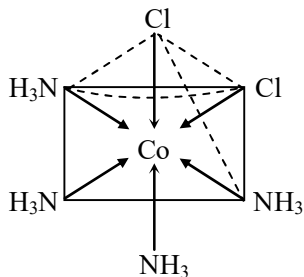
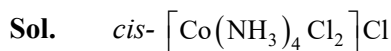

2 triangular faces having
1 N and 2 Cl atom

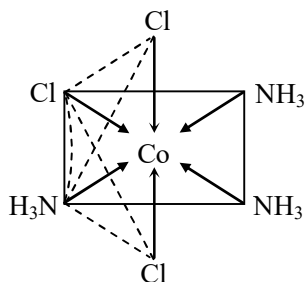
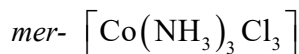

4 triangular faces having
1 N and 2 Cl atom

$$\text{Sum} = 2 + 4 = 6$$

Q.14 In the following reaction sequence, major products **X** and **Y** are acyclic monomers.

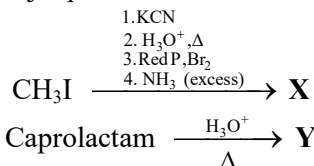

500 mol of **X** completely reacts with 500 mol of **Y** to give 1 mol of a single biodegradable acyclic copolymer **Z** as the only product. The amount of **Z** formed in grams is _____ .

Given:

Atomic mass (in amu): H : 1, C : 12, N : 14, O : 16, Br : 80

Ans. [85018.00]

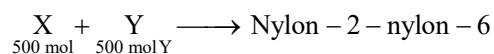
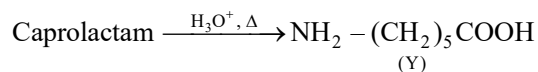
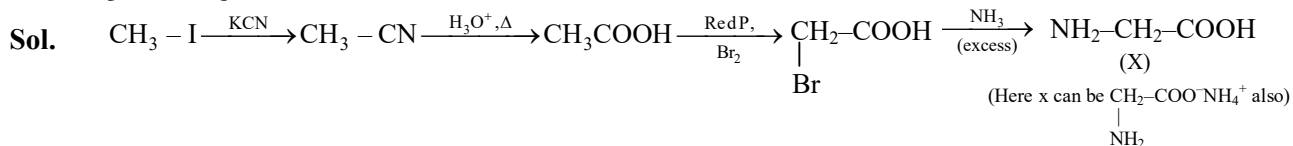

$$\text{Number of water moles lost} = 500 \times 2 - 1 = 999$$

$$\text{Mass of water lost} = 999 \times 18 = 17982$$

$$\text{Mass of Z} = 75 \times 500 + 131 \times 500 - 999 \times 18$$

$$37500 + 65500 - 17982 = 85,018 \text{ g}$$

SECTION – 4 (Maximum Marks: 8)

- This section contains **TWO (02)** question stems.
- There are **TWO (02)** questions corresponding to each question stem.
- The answer to each question is a **NUMERICAL VALUE**.
- For each question, enter the correct numerical value corresponding to the answer in the designated place using the mouse and the on-screen virtual numeric keypad.
- If the numerical value has more than two decimal places, **truncate/round-off** the value to **TWO** decimal places.
- Answer to each question will be evaluated **according to the following marking scheme** :
Full Marks : +2 If **ONLY** the correct numerical value is entered in the designated place;
Zero Marks : 0 In all other cases.

Question Stem for Question Nos. 15 and 16

Two volatile liquids **A** and **B** form an ideal solution. Consider a 5 molal solution of **B** in **A** inside a closed container having a total vapour pressure of 100 mm Hg at 300 K. The vapour pressure of pure **A** at 300 K is 105 mm Hg. Assume that **A** and **B** behave as ideal gases in the vapour phase.

Given :

The gas constant $R = 0.08 \text{ L atm K}^{-1} \text{ mol}^{-1}$

Molar mass of **A** is 50 g mol^{-1}

Molar mass of **B** is 57 g mol^{-1}

Density of liquid **B** at 300 K is 0.5 g / mL

$1 \text{ atm} = 760 \text{ mm Hg}$

Q.15 At 300 K, the ratio of the molar volume of pure **B** in vapour phase to its molar volume in liquid phase is _____ .

Ans. [2000.00]

$$100 = 105(X_A) + P_B^{\circ}(X_B)$$

$$= 105 \times \frac{1000/50}{\frac{1000}{50} + 5} + P_B^{\circ} \left(\frac{5}{\frac{1000}{50} + 5} \right)$$

$$= 105 \times \frac{20}{25} + P_B^{\circ} \left(\frac{5}{25} \right)$$

$$P_B^{\circ} = 80 \text{ mm}$$

$$d_B = 0.5 \text{ g / mL}$$

$$\text{Molar volume in liquid Phase} = \frac{57}{0.5} = x$$

$$\text{Molar volume in vapour Phase} = \frac{V}{n} = \frac{RT}{P} = \frac{0.08 \times 300}{\frac{80}{760}}$$

$$= 228 \times 10^3 \text{ mL} = x'$$

$$\frac{x}{x'} = \frac{\frac{57}{0.5}}{228 \times 10^3} = \frac{114}{228 \times 10^3} = \frac{1}{2000}$$

$$\text{So, } \frac{x'}{x} = 2000$$

Q.16 The mole fraction of **B** in vapour phase which is in equilibrium with this solution is .

Ans. [00.16]

Sol.

$$(X_B)_y = \gamma_B = \frac{80 \times \frac{1}{5}}{100} = 0.16$$

Question Stem for Question Nos. 17 and 18

Consider the following reaction sequence in which **J**, **K**, **L** and **M** are the major products.

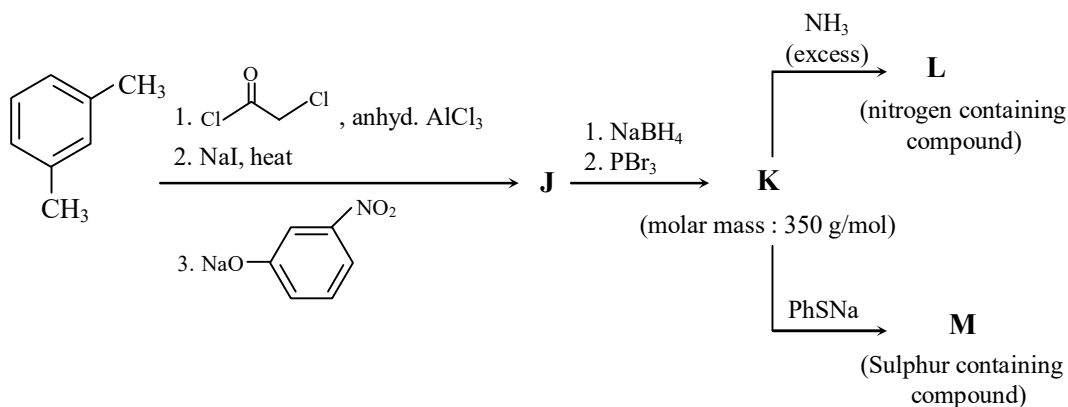

Given:

Atomic mass (in amu): H : 1, C : 12, N : 14, O : 16, S : 32, Br : 80, Ba : 137

Q.17 The volume of 1 M aqueous H₂SO₄ required to completely neutralize the ammonia evolved from 5.72g of **L** in Kjeldahl's method of nitrogen estimation is _____ mL.

Ans. [10.00]

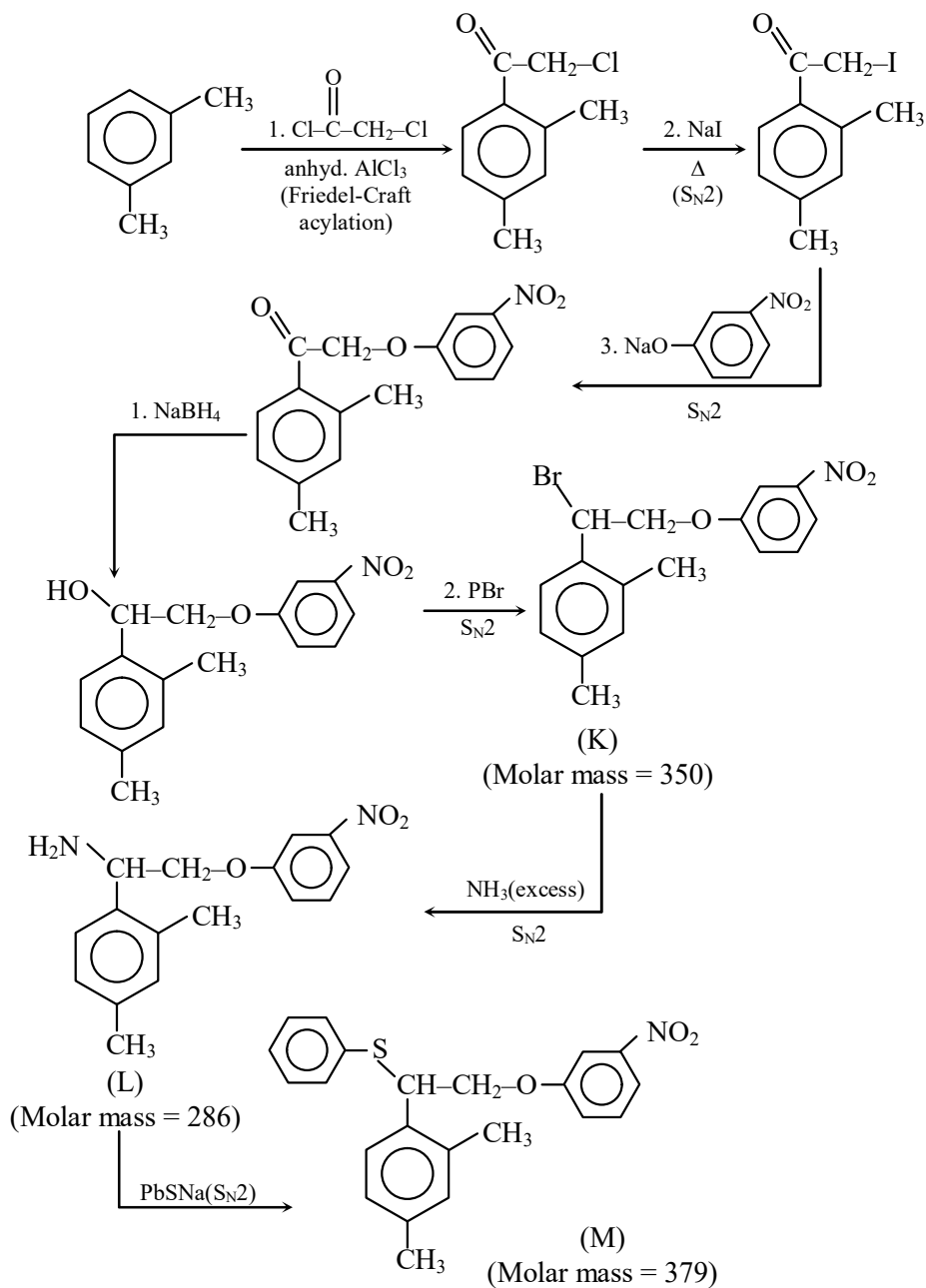

$$\text{Moles of } L = \frac{5.72}{286} = 0.02 \text{ mol} = \text{moles of } \text{NH}_3$$

\therefore g-equivalents of $\text{NH}_3 = \text{g-equivalents of } \text{H}_2\text{SO}_4$

$$0.02 \times 1 = (1 \times 2) \times V$$

$$\therefore V = \frac{0.02}{2} = 0.01 \text{ L} = 10 \text{ mL}$$

Q.18 In sulphur estimation by Carius method, the amount of BaSO_4 formed from 3.79 g of **M** is _____ g.

Ans. [02.33]

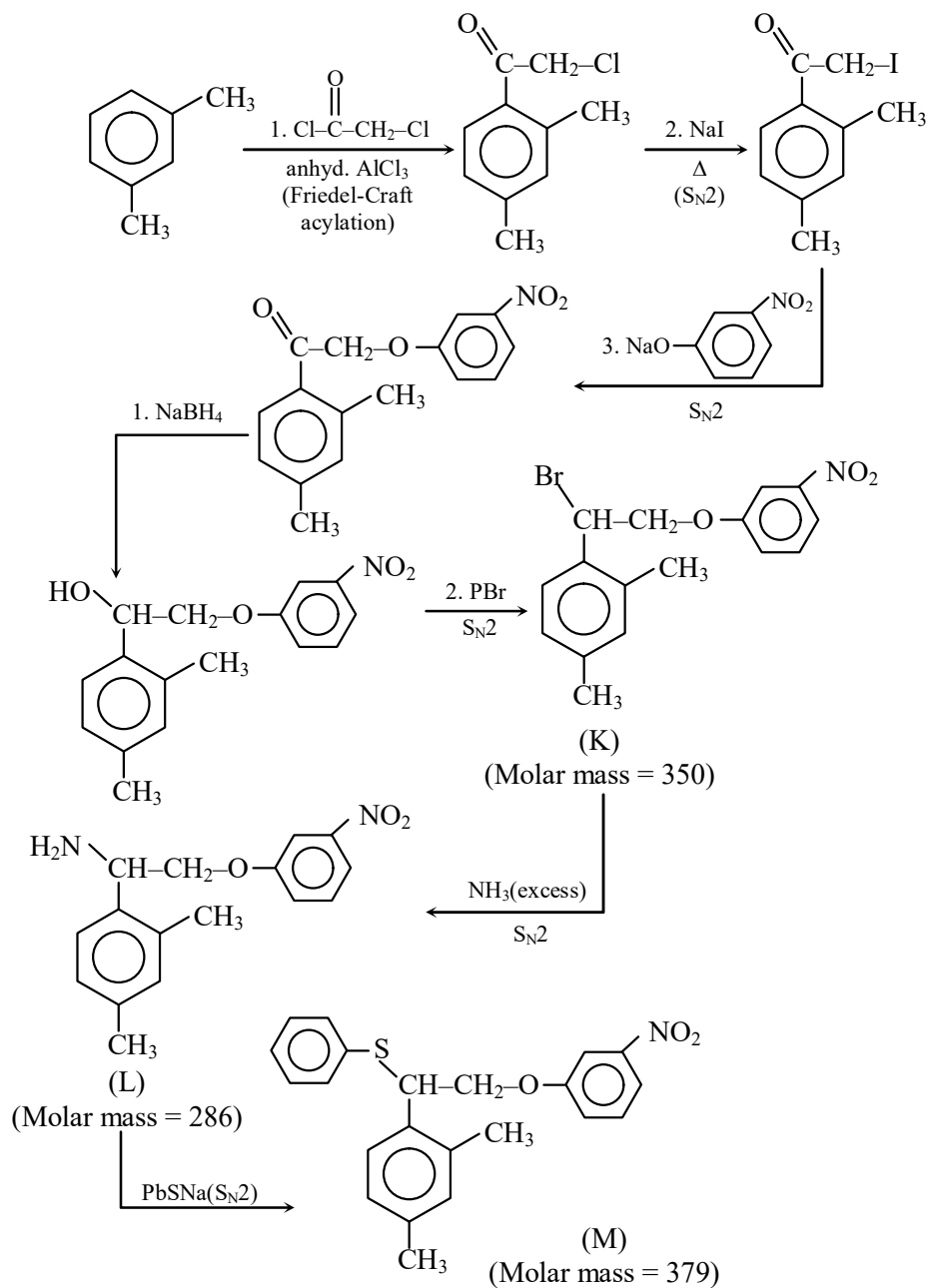

$$\text{Moles of M} = \frac{3.79}{379} = 0.01 \text{ moles} = \text{moles of BaSO}_4$$

$$\therefore \text{Mass of BaSO}_4 \text{ formed} = 0.01 \times 233 = 2.33 \text{ g}$$